

World Class Design | World Class Function | 30 Years Expertise In Industrial Motor Control

HG102957 ISS3

APPLICATION MANUAL: 340i 680i 1220i



SPRINT **ELECTRIC**



NOTE. These instructions do not purport to cover all details or variations in equipment, or to provide for every possible contingency to be met in connection with installation, operation, or maintenance. Should further information be desired or should particular problems arise which are not covered sufficiently for the purchaser's purposes, the matter should be referred to the local Supplier sales office. The contents of this document shall not become part of or modify any prior or existing agreement, commitment, or relationship. The sales contract contains the entire obligation of Sprint Electric Ltd. The warranty contained in the contract between the parties is the sole warranty of Sprint Electric Ltd. Any statements contained herein do not create new warranties or modify the existing warranty.

HEALTH AND SAFETY AT WORK

Electrical devices can constitute a safety hazard. It is the responsibility of the user to ensure the compliance of the installation with any acts or bylaws in force. Only skilled personnel should install and maintain this equipment. If in doubt refer to the supplier.

Note. The contents of this document are believed to be accurate at the time of printing. The manufacturers, however, reserve the right to change the content and product specification without notice. No liability is accepted for omissions or errors. **No liability is accepted for the installation or fitness for purpose or application of the 340i / 680i / 1220i motor drive units.**

1 Table of contents

| | | |
|-----|---|----|
| 1 | Table of contents | 2 |
| 2 | 340i Block Diagram and terminal listing. | 3 |
| 3 | Typical applications..... | 8 |
| 3.1 | ON OFF switch with ramp to stop or coast to stop..... | 8 |
| 3.2 | Zero reference interlock and Stop / Start pushbuttons. | 9 |
| 3.3 | Using an external 4-20mA speed signal | 10 |
| 3.4 | Torque control | 11 |
| 3.5 | Load sharing slave single direction..... | 12 |
| 3.6 | Low voltage speed feedback | 13 |

2 340i Block Diagram and terminal listing.

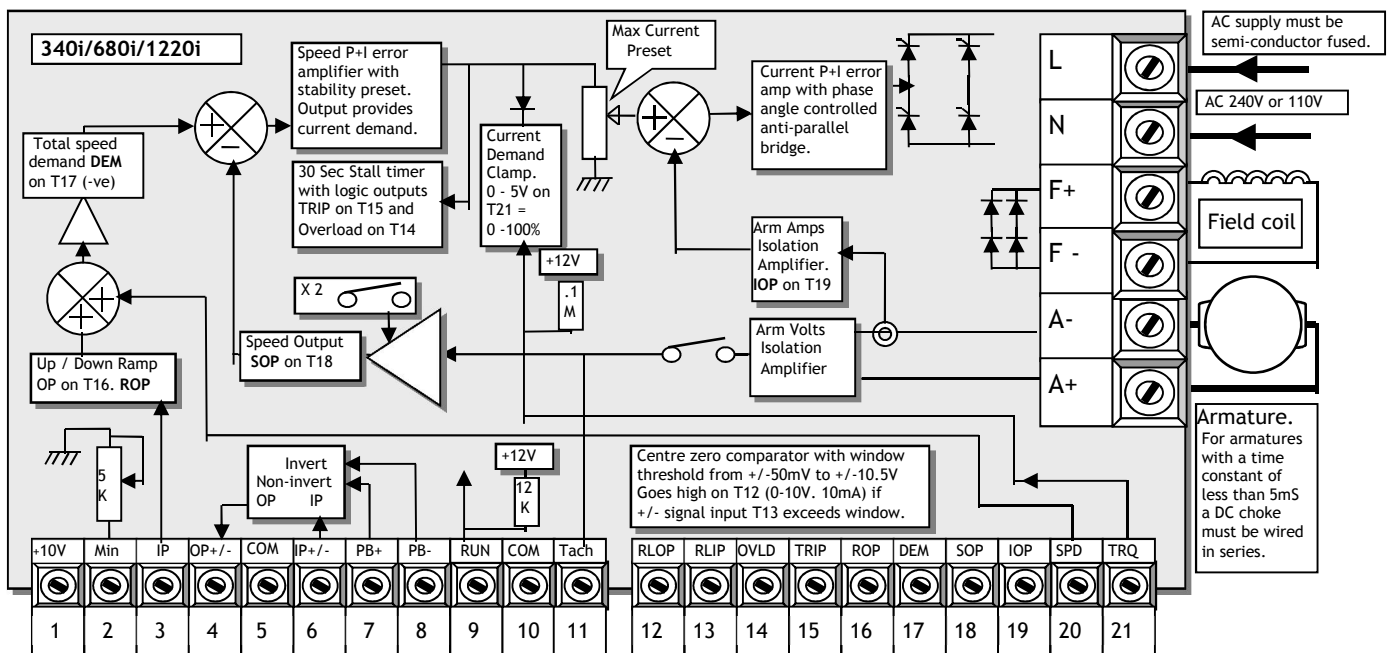

- 1 **+10V** output. 10mA max. (Use a 10K Ohm pot for external speed reference).
- 2 **MIN SPEED**. (Bottom end of external pot. 5K Ohms preset to common).
- 3 **IP**. Speed input. 0 to +/-10V speed input from pot wiper. 47K internal pull down.
- 4 **OP+/-**. +/-10.5V range. Input from T6. Invert with pushbutton input T8 open. Non-invert with pushbutton input T7. 10mA max.
- 5 **COM**. Common. (0 Volts)
- 6 **IP+/-**. Input to pushbutton controlled +/- signal channel. OP on T4. 50K Ohms impedance for invert mode, 10M input impedance in non-invert mode.
Note. This channel can invert input signals in the range +/-10.5V. It can also buffer (i.e. non-invert) signals in the range 0V to +10.5V. (It cannot buffer negative signals. If you try to buffer a negative signal the output will be positive).
Note. If using a high resistance external pot for positive signals e.g. greater than 20KOhms, then this channel can be used to buffer it using the non-invert mode.
- 7 **PB+** Pushbutton input. 47K Ohm pull up to +12V. Connect to T5 **COM**. Latches T4 to buffer (non-invert) positive T6 signals when opened, provided T8 **PB-** is connected to T5 **COM**.
- 8 **PB-** Pushbutton input. 47K Ohm pull up to +12V. Connect to T5 **COM**. Latches T4 to invert T6 when opened. T7 **PB+** may be open or connected to T5 **COM**.
 See truth table below for T7 and T8 operation. See terminal 6 **IP+/-** for notes.

| PB+ Terminal 7 | PB- Terminal 8 | Input T6 to output T4 mode |
|-----------------------|-----------------------|---|
| Closed to Common | Open circuit | Invert (+/-10.5V range) |
| Closed to Common | Closed to Common | Remains in prevailing mode. Powers up in invert mode. |
| Open circuit | Closed to Common | Non-invert (0 to +10.5V range) |
| Open circuit | Open circuit | Invert (+/-10.5V range) |

a) Hence if **PB+ Terminal 7** remains open then a switch on **PB- Terminal 8** can be used to change modes.

b) If both **PB+ Terminal 7** and **PB- Terminal 8** remain open then the invert mode is established.

c) If both **PB+ Terminal 7** and **PB- Terminal 8** are connected to common then the desired mode can be established by momentarily opening **PB+ Terminal 7** for non-invert, or **PB- Terminal 8** for invert mode. The mode remains latched when the common connection is re-established. This is useful for end of travel reversal. To implement, connect T1 +10V to T6 IP+/- and use the T4 OP+/- as the reference to the external max speed pot. Then connect the normally closed contacts from microswitches on the track, to the pushbutton inputs T7 **PB+** and T8 **PB-** such that when the load reaches and opens the microswitch it toggles the reference in the opposite direction.

- 9 **RUN**. Internal 12K pull up to +12V. Open to stop, close to COMMON to run. **WARNING. RUN is an electronic inhibit function. The field remains energised, and all power terminals 'live'. RUN must not be relied on to ensure the machine is stationary during hazardous operations. Remove the power source to the system.**

Opening T9 **RUN** will cause immediate drive inhibit and hence if the motor is rotating at the time it will coast to zero speed.

- 10 **COM**. Common. (0 Volts)
 11 **TACH** input. The tach must be opposite polarity to speed input. 1.5 MOhms.
 12 **RLOP**. Relay driver. +10.5V active high. Flywheel diode to COM.

Note. The output is current limited. When in current limit, the output voltage achieved, depends on the resistance of the load multiplied by the available current limit at that voltage, according to the table below.

| Output voltage | Typical current limit available | Typical Load resistance |
|----------------|---------------------------------|-------------------------|
| 10.5V | 1mA | Greater than 10K Ohms |
| 10.0V | 10 mA | 1000 Ohms |
| 9.5V | 15 mA | 633 Ohms |
| 9.0V | 20 mA | 450 Ohms |
| 8.5V | 25mA | 340 Ohms |
| 8.0V | 30mA | 267 Ohms |
| Below 8V | 30 mA | Less than 267 Ohms |

When driving relays, ensure the coil operating range is suitable. E. g. a 12V relay with a coil operating range of 80-110% will energise at voltages of 9.6V and above (80% of 12V). Hence it must have coil resistance greater than 633 Ohms for the output to be capable of achieving the desired voltage. (See table above).

Diagram of relay driver output stage

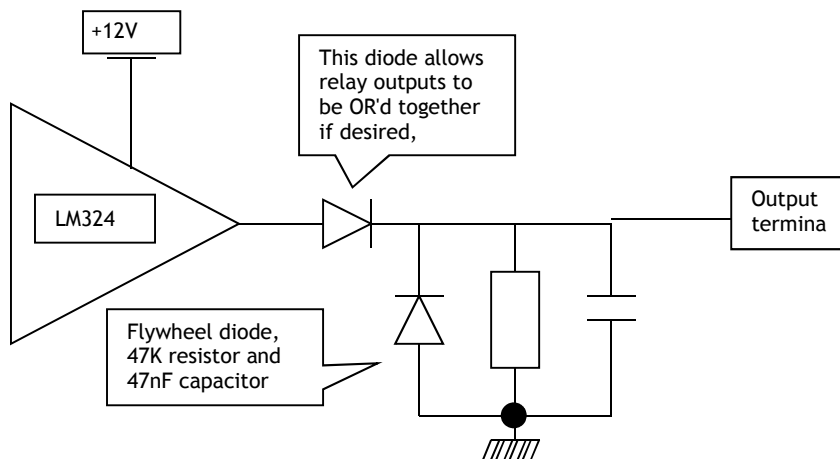

- 13 **RLIP.** Relay driver input. Accepts 0 to +/- 10.5V signal inputs. The threshold to activate the relay driver is symmetrical around zero, and set by the RELAY preset between +/- 0.05V and +/-10.5V. When the T13 input exceeds the positive or negative threshold, then the T12 RELAY DRIVER OUTPUT is turned ON. Typical uses include zero speed detector, zero current detector, stall detector etc.. The input will accept any output provided on other control terminals. 50K Ohm pull down to common.

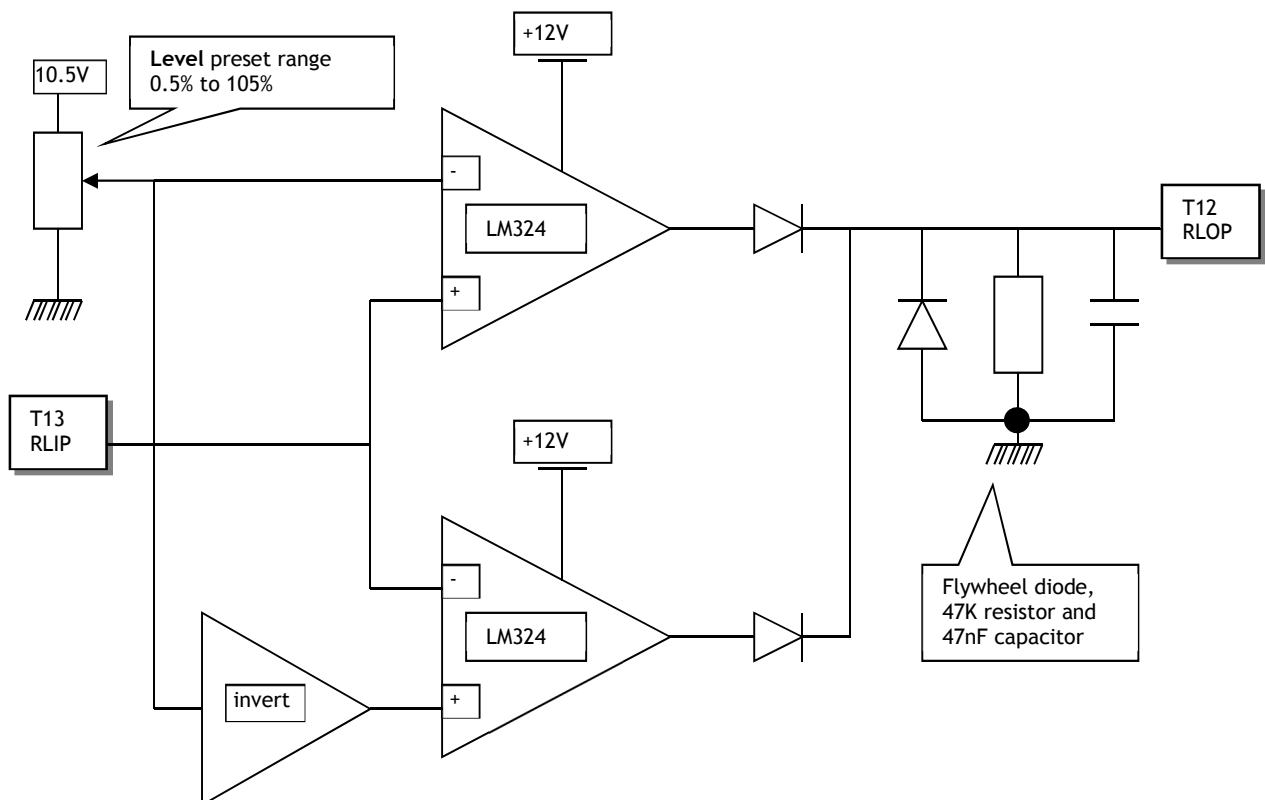

- 14 **OVLD.** Overload. This output goes high (+10.5V) if the current demand exceeds 100% and the stall timer starts timing. Flywheel diode to COM. See T12 **RLOP** for details of the output drive capability and configuration.

Note. It stays high if the overload subsequently results in a stall trip condition. The stall timer will allow 150% motor current for approximately 30 seconds before tripping. The overload integrator can tolerate 50% overload x 30 secs = 1500 units. (A 50% overload is 150% of motor current set on I_{max})

Available overload time prior to trip = 1500 / Overload % in seconds

Examples.

| | | |
|----------------------|---|--------------------|
| Other overload times | 125% I _{max} current for 60 secs | (1500 / 25 =60) |
| | 112.5% I _{max} current for 120 secs. | (1500 / 12.5 =120) |

For the overload capability to be fully restored after an overload that has **not** resulted in a trip, the load must require an equivalent overload current% x time **below** the 100% motor current rating.

E.g. If the load stayed at 150% for 15 seconds, then returned to 100% the overload integrator has used up half of its available units. To reset the integrator to zero again the load would have to run at say 50% for 15 seconds, or 99% for 750 seconds for example.

Note. The 100% level for the stall timer is set automatically by the I_{max} preset. The **stall** lamp will get progressively brighter as the stall timer integrates. It will be completely extinguished when the stall timer integrator is empty. I.e. Full overload capability available.

Note. The stall timer is actuated by current demand exceeding 100% when the desired speed remains unsatisfied. E.g. Excess load, insufficient supply volts, loss of feedback, saturated feedback, insufficient torque, jammed shaft. This allows the protection to be more comprehensive than overcurrent alone.

- 15 **TRIP.** This output goes high (+10.5V) and latches high when the stall timer has timed out (in which case T14 OVLD will also be high) **OR** if the fan alarm has operated (in which case T14 OVLD will be low). Flywheel diode to COM. See T12 **RLOP** for details of the output drive capability and configuration.
- 16 **ROP.** Ramp output. 0 to +/-10V output for 0 to +/-10V input. 1K Ohm output impedance.
- 17 **DEM.** Demand output. 0 to +/-10V output for 0 to +/-100% speed demand. 1K Ohm output impedance. Represents the inverted total speed demand.
- 18 **SOP.** Speed output. 0 to +5V output for 0 to +100% speed feedback. 1K Ohm output impedance. NOTE: Prior to LA issue 11 (see side of terminal block), the output at this terminal was 0 to +10V.
- 19 **IOP.** Current output. 0 to +5V output for 0 to +100% armature current. Maximum output +7.5V for +150% current. 1K Ohm output impedance.
- 20 **SPD.** Auxiliary speed input. Added to main input. Input impedance 100
0 to +/-10V input for 0 to +/-100% speed demand, direct input fast response.

- 21 **TRQ.** Torque input. 100K Ohms pull up to +12V.
0 to +5V input for 0 to +/-100% current demand. This input acts as a clamp on the current demand produced by the speed loop. Also if the speed loop current demand falls below the input clamp level then the speed loop has priority. For the clamp to operate, the speed loop current demand must be arranged to exceed the clamp level by ensuring the speed demand is high enough.

- A+ Motor armature + Form Factor typically 1.5
A- Motor armature -
F- Motor Field - (No connection required for permanent magnet motors).
F+ Motor Field +(For half wave field volts 0.45 X AC, connect field to F- and N).
N AC supply. 110V AC or 240V AC +/-10%, 50-60 Hz.
L AC supply. 110V AC or 240V AC +/-10%, 50-60 Hz.

3 Typical applications

3.1 ON OFF switch with ramp to stop or coast to stop

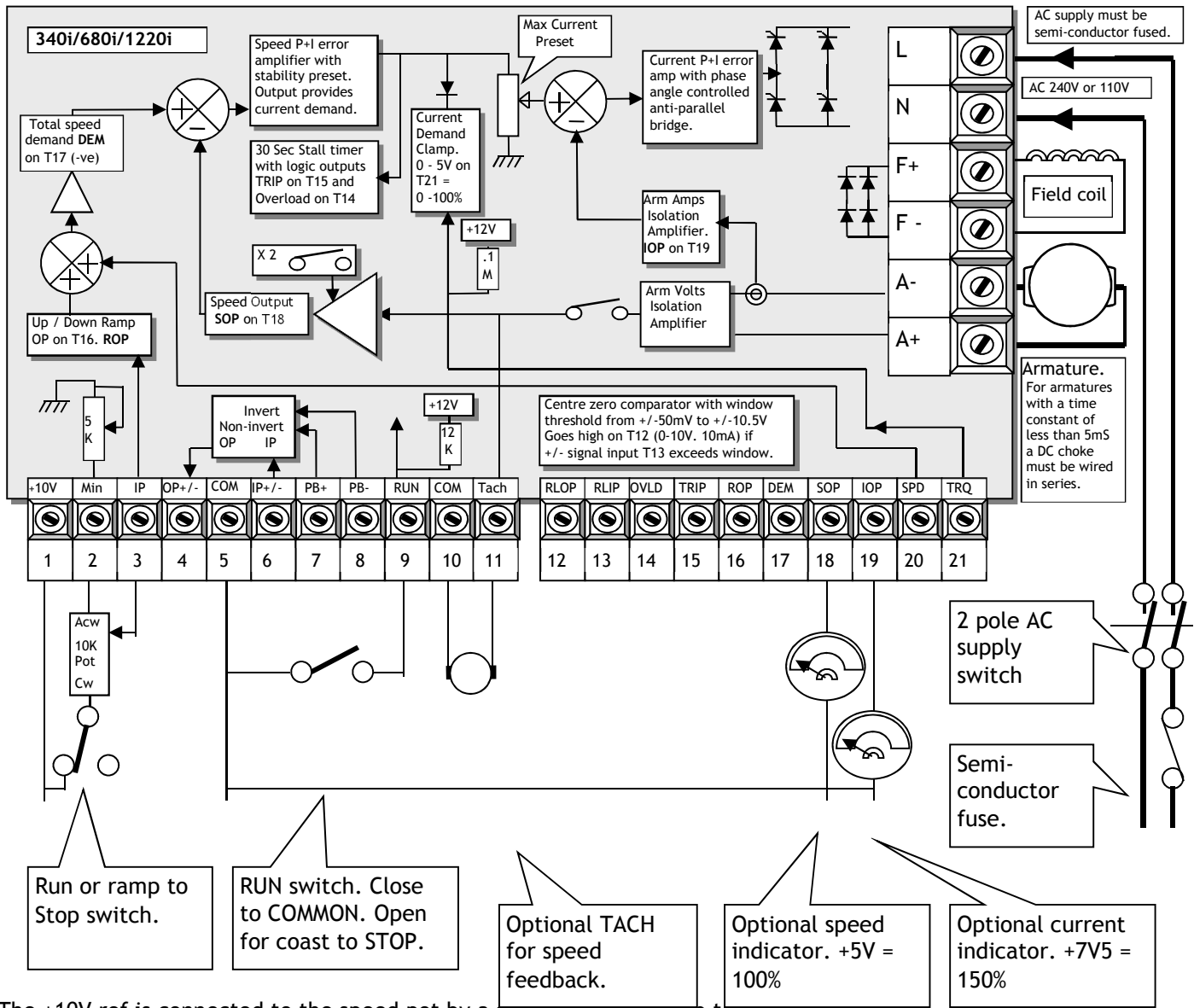

The +10V ref is connected to the speed pot by a switch giving a ramp to zero when opened.

Note. The AVF/tach select switch must be set, and the appropriate speed scale range selected for the max feedback volts, depending on the source of speed feedback.

If a tachogenerator is used the polarity on T11 must be negative.

3.2 Zero reference interlock and Stop / Start pushbuttons.

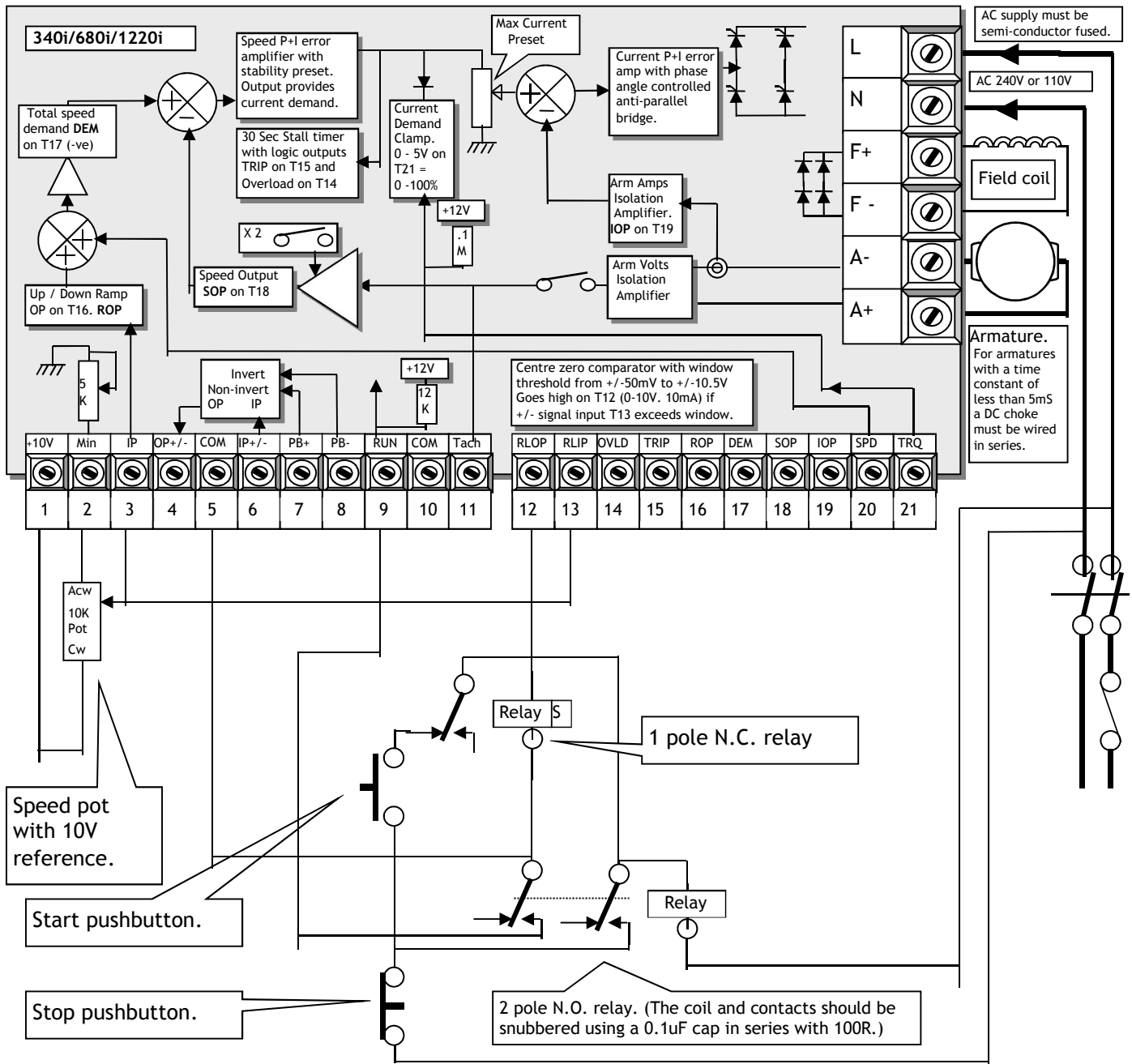

With the unit powered up and the reference above the threshold set by the relay driver level preset, the signal relay will be energised, and the contact will be closed. Hence the Start pushbutton is inoperative. When the operator brings the external reference to zero, the signal relay will de-energise and the Start pushbutton will be operative.

Then, when the Start pushbutton is closed, and providing the Stop pushbutton is also closed, the 2 pole relay will energise. This will latch in the Start condition and close the RUN line. The drive can now be operated at any speed until the Stop pushbutton is pressed. In order to start, the operator must once more ensure the external reference is zero.

3.3 Using an external 4-20mA speed signal

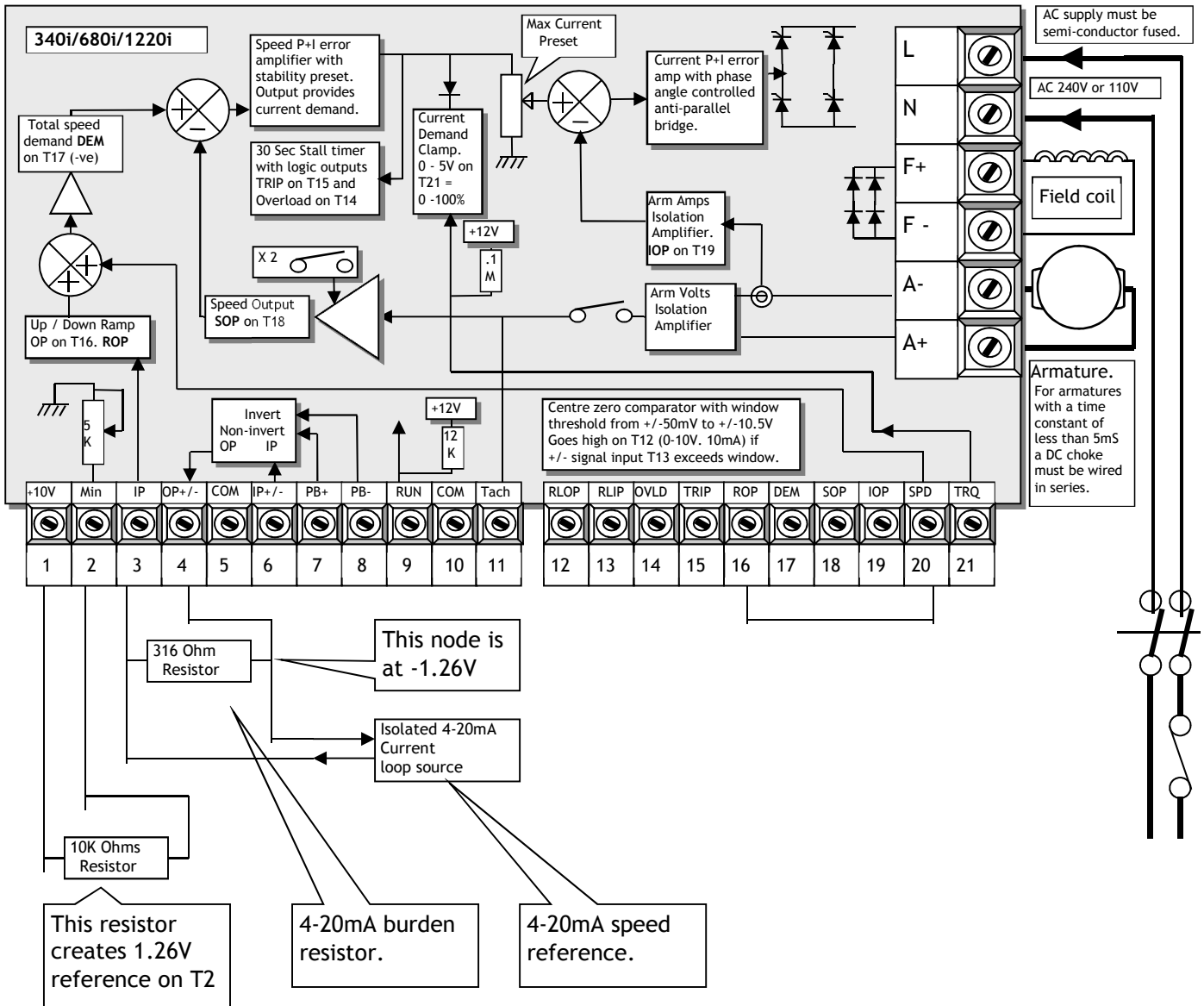

The 4-20mA floating source is imposed across a burden resistor of value 316 Ohms. (Standard E96 value). This creates a voltage of 1.26 Volts at 4mA across the resistor. This represents the system zero.

The 10K Ohm resistor is used in conjunction with the Min speed preset to provide a reference of 1.26 volts which is then inverted in the +/- channel.

The burden resistor is referred to the -1.26V source from T4 and hence the voltage created at 4mA on the speed input T3 is zero volts as required.

With 20mA flowing (which represents 100% speed) the voltage across the burden is 6.32 Volts. This provides a speed signal of 6.32 - 1.26 = 5.06 Volts on T3.

The T16 Ramp output is linked to T20 speed input to double the speed input strength and hence the 5V speed reference will provide the standard speed scaling range.

For 0 - 20mA sources use a 249 Ohm burden resistor and refer it to common instead of -1.26 Volts.

3.4 Torque control

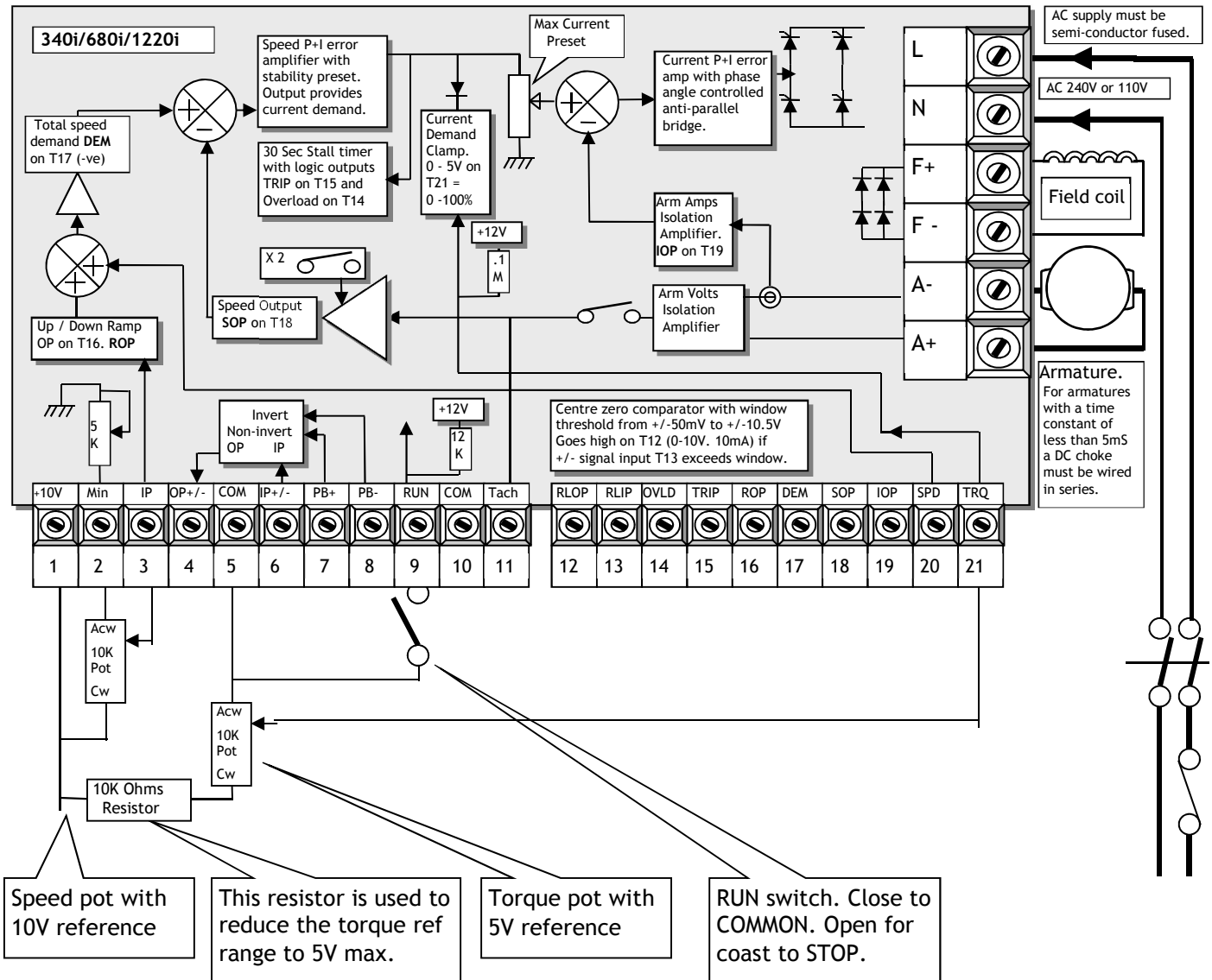

T21 is 0 to +5V input for 0 to 100% current demand. This torque signal acts as a clamp on the current demand produced by the speed loop.

If the speed loop current demand falls below the input clamp level then the speed loop will regain control at a speed lower than the clamp level allows. For the clamp to operate, the speed loop current demand must be arranged to exceed the clamp level by ensuring the speed demand is high enough.

3.5 Load sharing slave single direction.

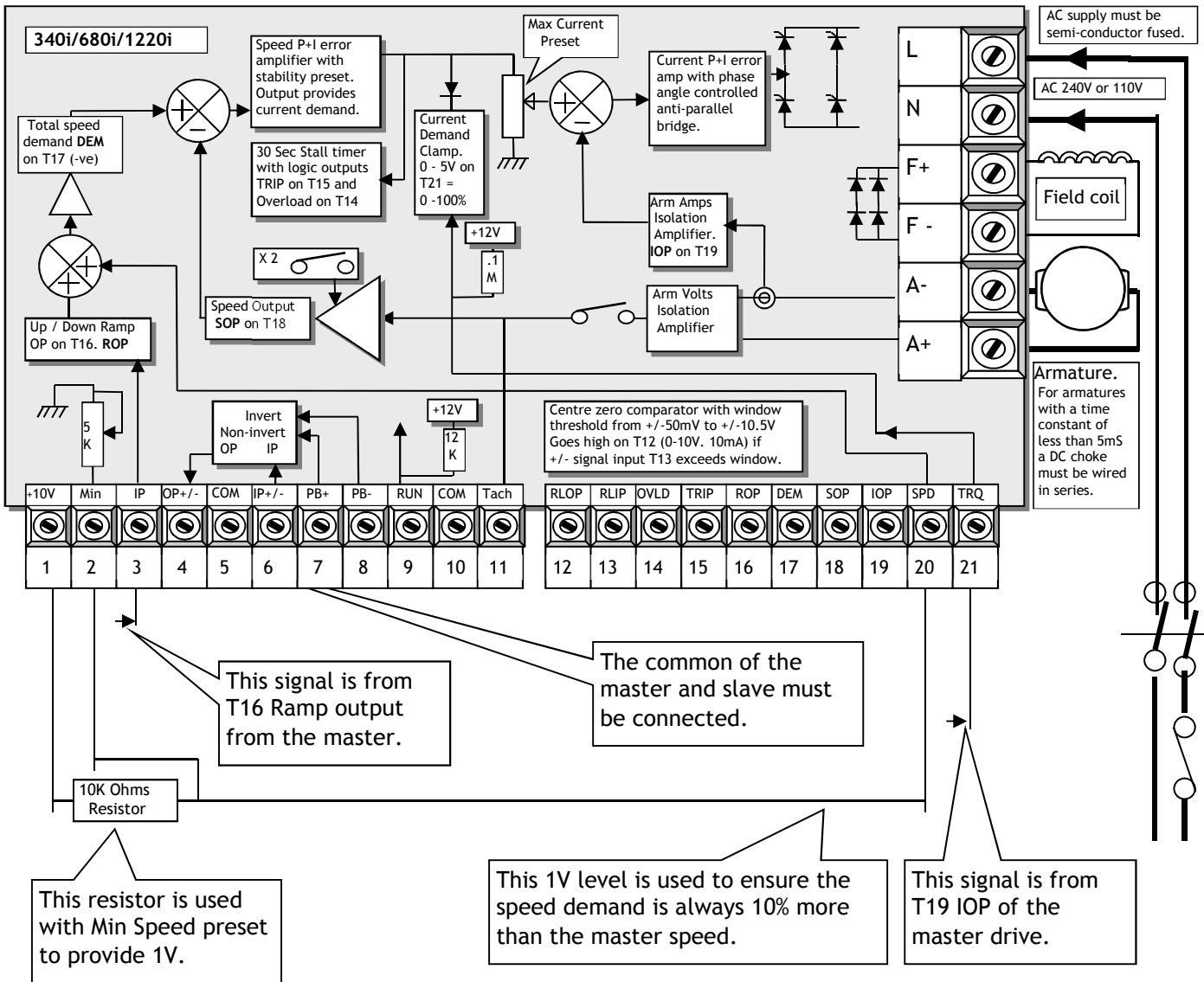

Load sharing is used when a large load is driven by more than 1 motor and each motor must bear the load in the same proportion. The motors are linked mechanically via the load and usually rotate at the same speed.

T21 requires a 0 to +5V input for 0 to 100% current demand. This torque acts as a clamp on the current demand produced by the speed loop. The signal is derived from the master drive T19 current output. Hence whatever current is required by the master will also be provided by the slave.

To ensure that the current demand of the slave is always clamped by the torque input a 1V (10%) speed signal is added to the direct speed input. This is derived from an external 10K resistor and the Min speed preset.

The main speed reference is sourced from the master T16 ramp output.

3.6 Low voltage speed feedback

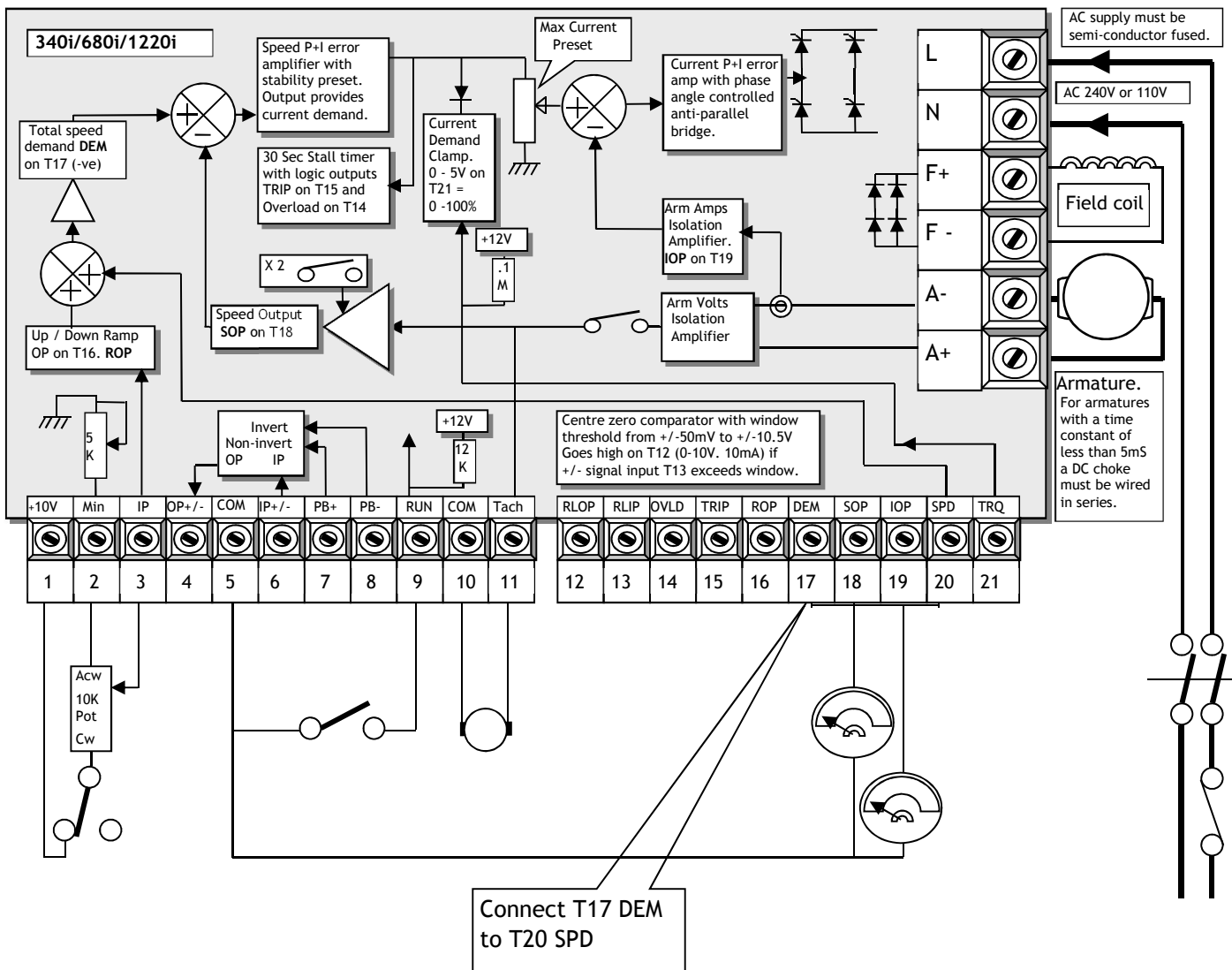

The output on T17 is the inverted total speed demand. By connecting this into T20 the feedback scaling is reduced to 50% for both armature voltage and tacho feedback. Hence:

With Spd x 2 switch OFF (right) maximum speed feedback range = 20 to 50V.

With Spd x 2 switch ON (left) the maximum speed feedback range = 40 to 100V.

The speed output T18 will now provide 0 to +/- 5V for 0 to +/- 100% speed.

CAUTION should be exercised if using this technique with armature voltage feedback as a way of operating a low voltage motor from a relatively high voltage drive (e.g. 48V motor, 240V drive): The poor form-factor experienced by the motor in such cases may lead to reduced brush life and increased operating temperature. It is also possible, in the case of a permanent magnet motor, that demagnetisation will occur.

In such applications, it is preferable to match the AC supply to the DC armature voltage more closely. This may be achieved by the use of a low voltage drive, powered from a step-down transformer (e.g. 48V motor, LV60 drive, 240V to 60V auto-transformer). Please contact Sprint Electric Ltd if more information is required.

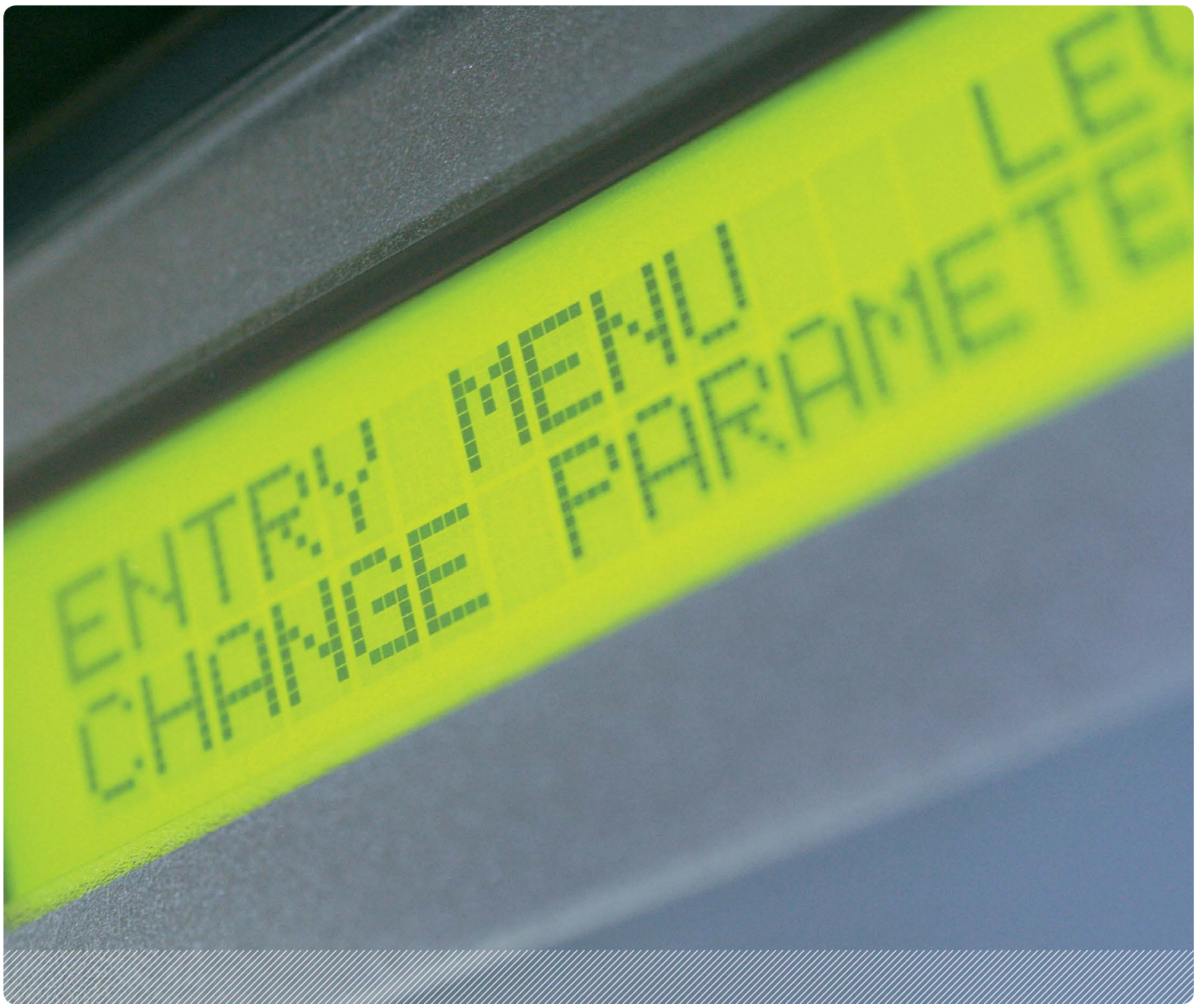

Find out more:
www.sprint-electric.com

Sprint Electric Ltd. Peregrine House, Ford Lane, Ford
Arundel, West Sussex, BN18 0DF United Kingdom

Tel: +44 (0)1243 558080

Fax: +44 (0)1243 558099

Email: info@sprint-electric.com

SPRINT **ELECTRIC**