

Najazd na krańcowy (styk NC) powoduje STOP silnika

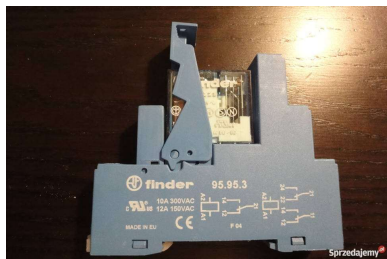

Przełącznik 24 VDC

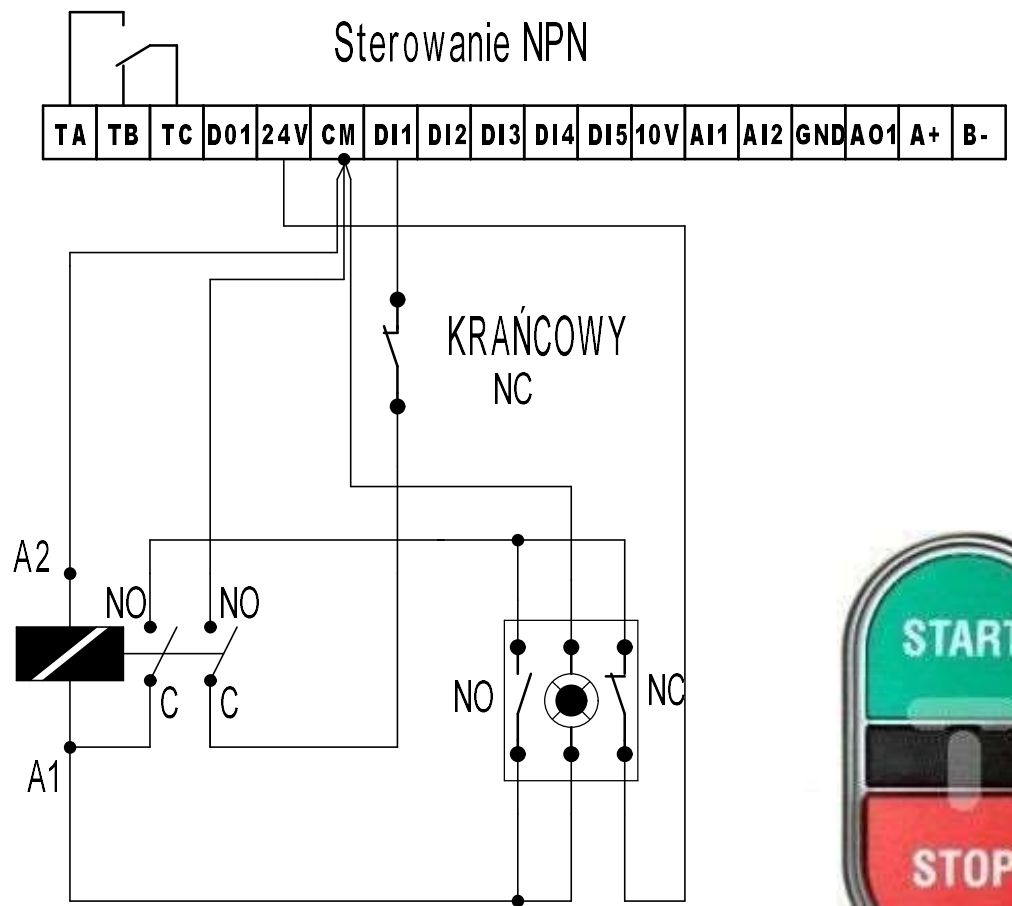

Lampka-LED 24DC Praca silnika

OPIS PRZYCISKÓW

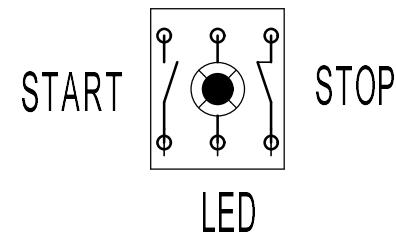

OPIS FUNKCJI :

- F200 = 1
- F201 = 1
- F203 = 0
- F208 = 0
- F228 = 4
- F220 = 1
- F316 = 15
- F317 = 16

