

© 2002EUROTHERM DRIVES LTD./INC.

DRN	PAB	PAB	PAB	PAB	PAB	PAB	PAB	PAB	PAB
D	15JAN01	20FEB01	20FEB01	04JUN01	18JUN01	03SEP01	13341	05SEP01	16212
E									
F									
G									
H									
I									
1									
2									
3									
4									
5									

DRN	PAB	PAB	PAB	PAB	PAB	PAB	PAB	PAB	PAB
D	15JAN01	20FEB01	20FEB01	04JUN01	18JUN01	03SEP01	13341	05SEP01	16212
E									
F									
G									
H									
I									
1									
2									
3									
4									
5									

DRN	PAB	PAB	PAB	PAB	PAB	PAB	PAB	PAB	PAB
D	15JAN01	20FEB01	20FEB01	04JUN01	18JUN01	03SEP01	13341	05SEP01	16212
E									
F									
G									
H									
I									
1									
2									
3									
4									
5									

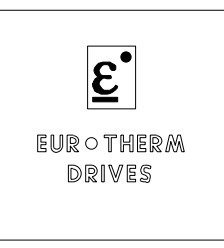

**DO NOT SCALE**  
 DIMENSIONS IN MM UNLESS OTHERWISE SPECIFIED

DRG SIZE TOLERANCES  
 A3 B GENERAL:  
 SCALE HOLES:  
 1:1 ANG:

DRN	PAB	PAB	PAB	PAB	PAB	PAB	PAB	PAB	PAB
D	15JAN01	20FEB01	20FEB01	04JUN01	18JUN01	03SEP01	13341	05SEP01	16212
E									
F									
G									
H									
I									
1									
2									
3									
4									
5									

FOR COMPONENTS MARKED THIS \*  
 PLEASE REFER TO BUILD VARIANT  
 TABLE SHOWN ON SHEETS 7 & 8  
 OF THIS SCHEMATIC

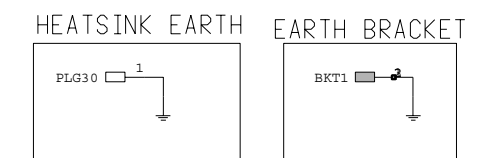
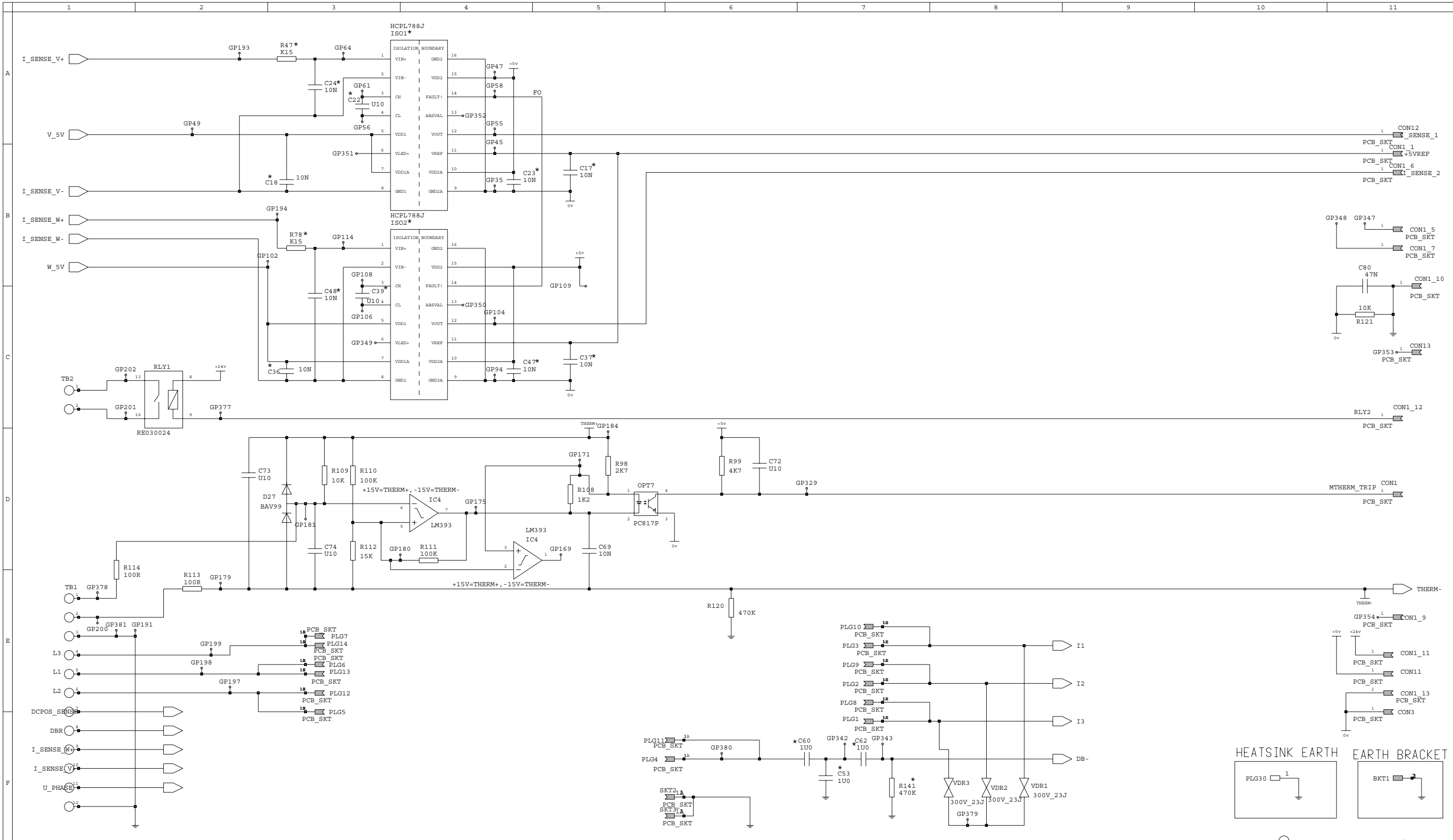

© 2002EUROTHERM DRIVES LTD./INC.

ISS	DATE	DRG	DRN	PAB	PAB	PAB	PAB	PAB	PAB	PAB	PAB	PAB	PAB
D	15JAN01												
E	20FEB01												
F	20FEB01												
G	04JUN01												
H	18JUN01												
I	03SEP01												
1	05SEP01												
2	13MAR02												
3	13MAR02												
4	25MAR02												
5	04OCT02												

MATERIAL	
FINISH	

MATERIAL	
FINISH	



DO NOT SCALE	
DIMENSIONS IN MM UNLESS OTHERWISE SPECIFIED	
DRG 150	SIZE A3
SCALE 1:1	ANG:
TOLERANCES	ENGINEERED WS
CHECKED	FIRST USED

ELECTRONIC STORAGE DETAILS: MENTOR GRAPHICS DESIGN ARCHITECT FILE	
MENTOR/INFP0LO /mentor/proj/dev/650/S1x2/AN464755_5	
DESCRIPTION	
TITLE	
650	
FRAME SIZE 2 POWER BOARD MV	
DRAWING NUMBER	AI 464755
SHT 2	OF 8

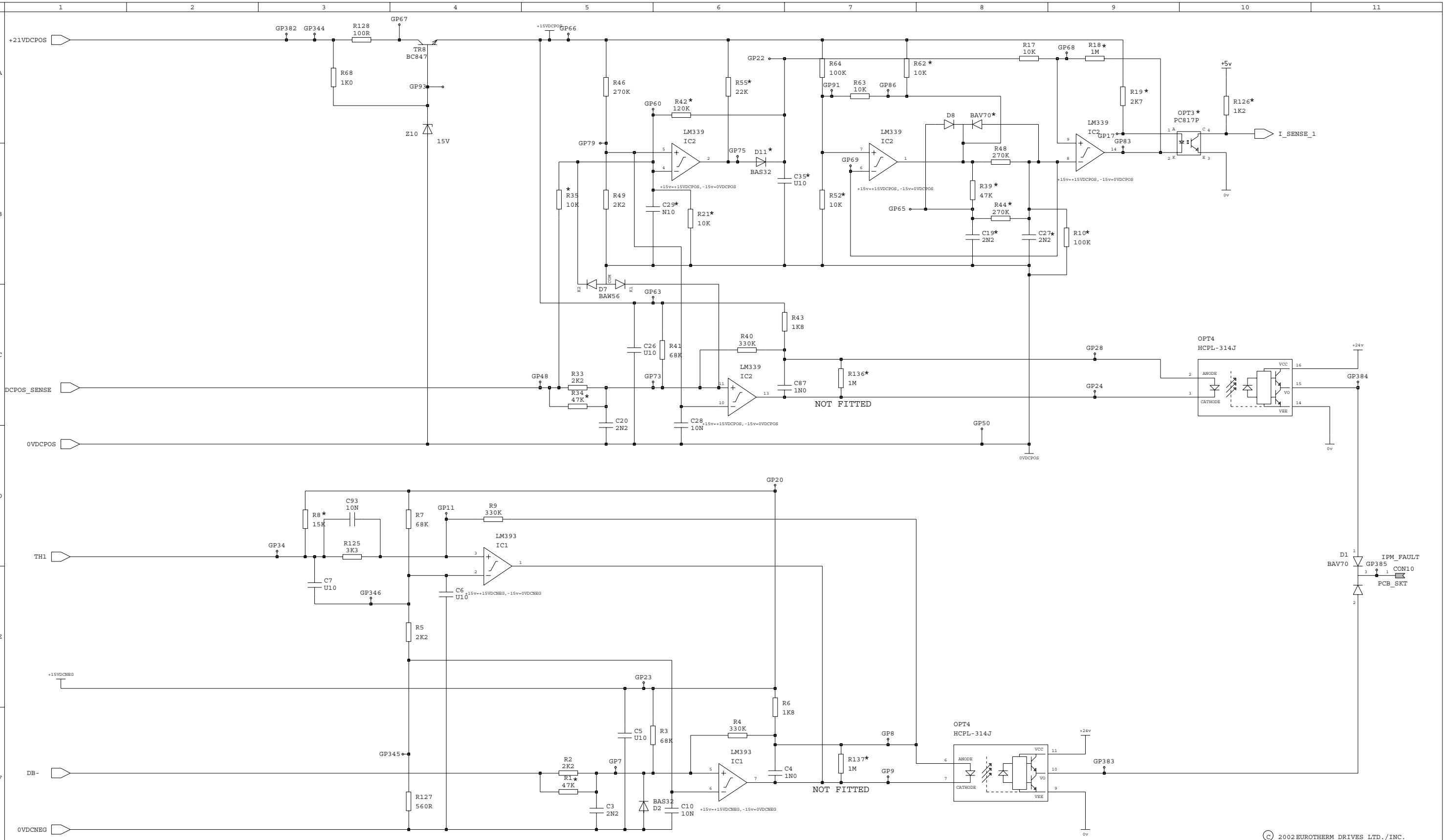

© 2002EUROTHERM DRIVES LTD./INC.

ISS	DATE	DRG	DRN	ECC	DRN
D	15JAN01	PAB			
E	20FEB01	PAB			
F	20FEB01	PAB			
G	04JUN01	PAB			
H	18JUN01	PAB			
I	03SEP01	PAB			
1	05SEP01	PAB			
2	13MAR02	PAB			
3	13MAR02	PAB			
4	25MAR02	PAB			
5	04OCT02	PAB			

MATERIAL	
FINISH	

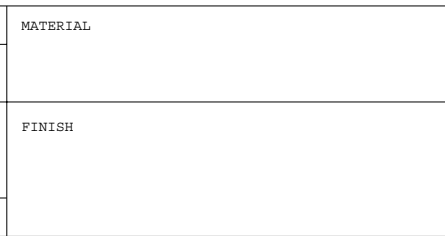

<b>DO NOT SCALE</b>		BS308/ANSI Y14.5M 82	
DIMENSIONS IN MM UNLESS OTHERWISE SPECIFIED		BS3939/IEEE Std91 84	
DRG 180	SIZE A3	TOLERANCES	ENGINEERED WS
SCALE 1:1	HOLES:	GENERAL:	CHECKED
	ANG:		FIRST USED

ELECTRONIC STORAGE DETAILS: MENTOR/INFP0LO		MENTOR GRAPHICS DESIGN ARCHITECT FILE	
DESCRIPTION		/mentor/proj/dev/650/S1x2/AN464755_5	
TITLE		650	
DRAWING NUMBER		AI 464755	
		SHT 3	OF 8

FRAME SIZE 2 POWER BOARD MV

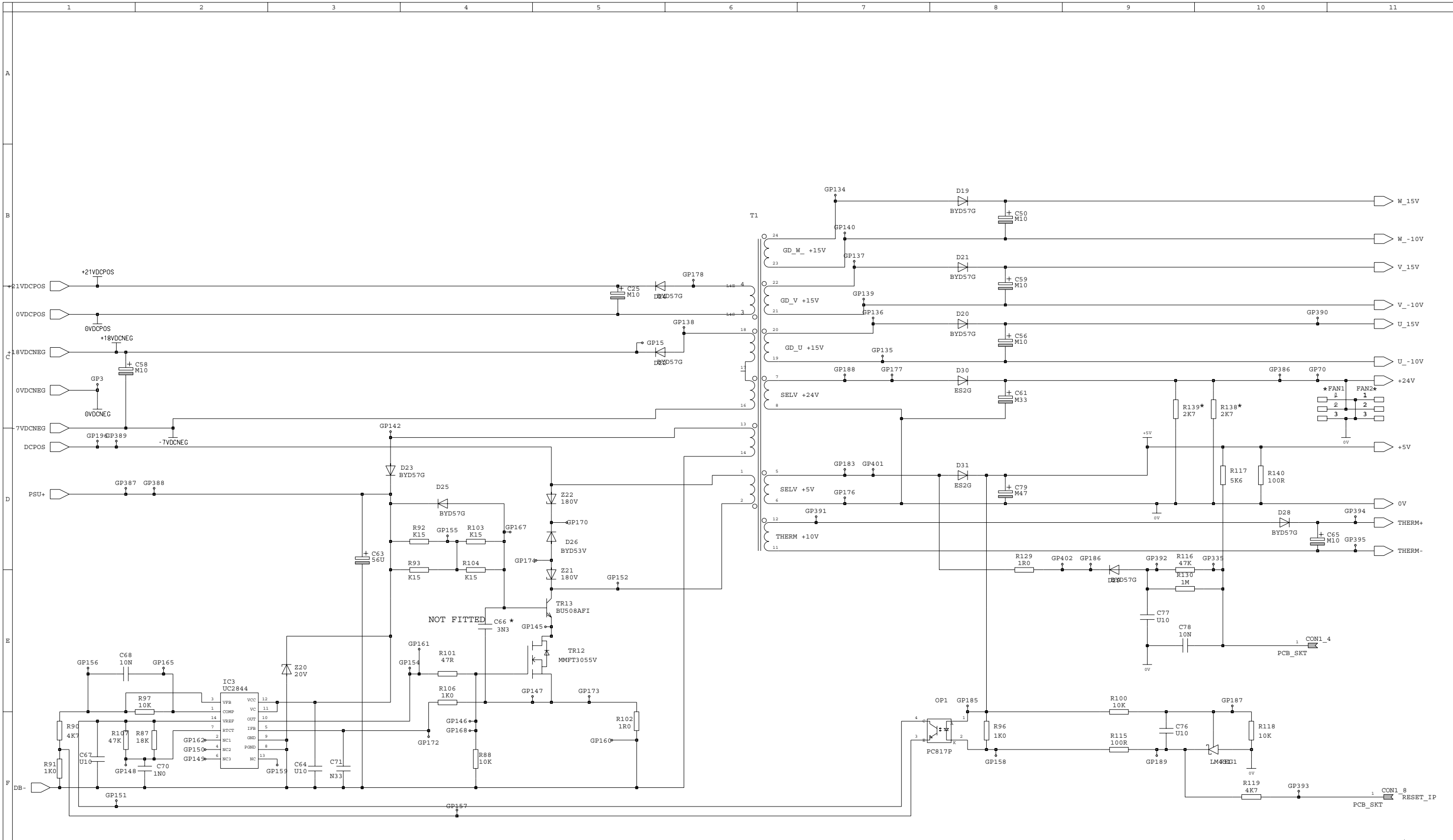

C 2002EUROTHERM DRIVES LTD./INC.

DRN	PAB	PAB	PAB	PAB	PAB	PAB	PAB	PAB	PAB	PAB
D	E	F	G	H	I	1	2	3	4	5
15JAN01	20FEB01	20FEB01	04JUN01	18JUN01	03SEP01	05SEP01	13MAR02	13MAR02	25MAR02	04OCT02
13341	16212	16683	16384	16641	17054	17054				

FINISH	
--------	--



**DO NOT SCALE**  
DIMENSIONS IN MM UNLESS  
OTHERWISE SPECIFIED

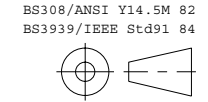

BS308/ANSI Y14.5M 82  
BS3939/IEEE Std91 84

DRG	SIZE	TOLERANCES
A3	B	GENERAL: HOLES: ANG:
SCALE	1:1	

ENGINEERED	WS
CHECKED	
FIRST USED	

ELECTRONIC STORAGE DETAILS: MENTOR/INFOFLO DESCRIPTION /mentor/proj/dev/650/Size2/AN464755_5		MENTOR GRAPHICS DESIGN ARCHITECT FILE	
TITLE		650	
FRAME SIZE 2 POWER BOARD MV			
DRAWING NUMBER	AI 464755	SHT	4
		OF	8

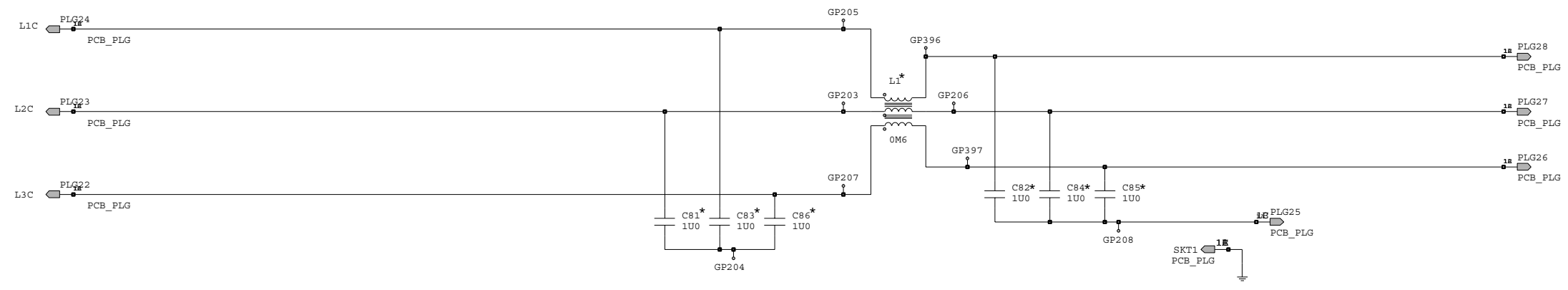

BOARD MANUFACTURING OBJECTS			
TOOL2	TOOL1	RSD1	LAB1
TEST T HOLE	TEST T HOLE	STATIC HAND	BARCODE

FILTER CHOKE BOARD 464755\_2

© 2002EUROTHERM DRIVES LTD./INC.

DRN	PAB	PAB	PAB	PAB	PAB	PAB	PAB	PAB	PAB		MATERIAL		<p><b>DO NOT SCALE</b> DIMENSIONS IN MM UNLESS OTHERWISE SPECIFIED</p>	BS308/ANSI Y14.5M 82	ELECTRONIC STORAGE DETAILS:	MENTOR GRAPHICS DESIGN ARCHITECT FILE			
ECC										FINISH	DRG 150			SIZE A3	TOLERANCES	ENGINEERED	WS	MENTOR/INFPLO	/mentor/proj/dev/650/Size2/AI464755_5
DATE	20FEB01	04JUN01	18JUN01	03SEP01	13341	16212	16683	16384	16641	040C102	17054			PAB	SCALE	GENERAL:	CHECKED		TITLE
ISS	F	G	H	I	1	2	3	4	5				1:1	HOLES:	FIRST USED		DRAWING NUMBER	AI 464755	SHT 5 OF 8



BOARD MANUFACTURING OBJECTS

RSD3 LAB3  
 STATI HAND BARCODE

LINK BOARD 464755\_3

© 2002EUROTHERM DRIVES LTD./INC.

ISS	DRN											MATERIAL		DO NOT SCALE DIMENSIONS IN MM UNLESS OTHERWISE SPECIFIED	BS308/ANSI Y14.5M 82 BS3939/IEEE Std91 84		ELECTRONIC STORAGE DETAILS: MENTOR/INFPLO DESCRIPTION /mentor/proj/dev/650/Size2/AI464755_5		MENTOR GRAPHICS DESIGN ARCHITECT FILE		
	ECC	PAB	PAB	PAB											TITLE 650						
	DATE	20FEB01	04JUN01	18JUN01	03SEP01	13341 PAB	16212 PAB	13MAR02	16683 PAB	13MAR02	16384 PAB	25MAR02			16641 PAB	04OCT02	17054 PAB			FRAME SIZE 2 POWER BOARD MV	
	SCALE	1:1													GENERAL:	ENGINEERED	WS	DRAWING NUMBER AI 464755		SHT 6 OF 8	
	HOLES:														ANG:	CHECKED	FIRST USED				



