ConfigEd Lite

Product Manual

For use with ConfigEdLite version 5.x

© Copyright Eurotherm Drives, Inc. 2002

All rights strictly reserved. No part of this document may be stored in a retrieval system or transmitted in any form. Although every effort has been taken to ensure the accuracy of this manual, it may be necessary, without notice, to make amendments or correct omissions in this document. Eurotherm Drives, Inc. cannot accept responsibility for damage, injury, or expenses resulting therefrom.

Procedures detailed in this manual are designed to be performed by personnel with sufficient training and/or experience. Only sufficiently qualified personnel familiar with the construction and operation of industrial drive equipment and the dangers of working with high-voltage electrical systems should attempt installation, adjustment, operation, or service of this equipment. Failure to follow these guidelines could result in damage to the equipment and severe injury or loss of life to personnel. If you are unsure of your qualifications or do not understand certain procedures in this manual, contact Eurotherm Drives Customer Service for assistance. Before attempting any procedures in this manual, including installation, verify that the model numbers on the product and in this manual match. If any discrepancy is found, contact Customer Service immediately.

Printed in the United States of America

RG352747 Issue 6

Contents

Chapter 1	INTRODUCTION	
	What is ConfigEd Lite?	1- 1
	Off-Line Configuration	1- 1
	Computer Compatibility	1- 2
Chapter 2	HANDLING	
	Unpacking Instructions	2- 1
	Special Handling	2- 1
Chapter 3	INSTALLATION & SETUP	
	Installation Procedure	3- 1
	Communicating With Your Drive	3- 4
Chapter 4	CREATING A CONFIGURATION	
	Opening a Default Configuration	4- 1
	Displaying the Configuration	4- 2
	Configuration Parameters	4- 3
	Displaying Parameters	4- 3
	Changing Parameters	4- 4
	Making Connections	4- 4
	Aligning Function Blocks	4- 5
	Saving a Configuration	4- 6
	Opening an Existing Configuration	4- 7
	Install a Configuration	4- 7
	Use "Get Info"	4- 7
	Install Configuration	4- 8
	Updating a Configuration	4- 8
	Creating Configuration Templates	4- 9
	Printing a Configuration	4- 9
Chapter 5	DOCUMENT A CONFIGURATION	
	Document a Configuration	5- 1
	Review Your Documentation	5- 1
	Print Your Documentation List	5- 2

ConfigEd Lite Manual

Chapter 6 ADVANCED FEATURES

Forms	6- 1
Create a Form	6- 1
Automatic Data Entry	6- 3

Chapter 7 TROUBLESHOOTING

Communications Problems	7- 1
Mismatched Baud Rates	7- 1
Baud Rate Set Too High	7- 1
Wrong Communications Port	7- 1
Drive P3 Mode Set Wrong	7- 1
Error Messages	7- 2

Chapter 8 REFERENCE

Function Blocks	8- 1
Inter-Sheet Connections	8- 1
Split Connections	8- 2
Drawing	8- 3
Drawing Tools	8- 4
Display Options	8- 6
Annotating Drawings	8- 6
Scratch Pad	8- 6

Chapter 9 APPENDIX

Menus	9- 1
File	9- 1
Edit	9- 1
Command	9- 1
Window	9- 2
Font	9- 2
Style	9- 2
Help	9- 2

Chapter 1 INTRODUCTION

WHAT IS CONFIGED LITE?

ConfigEd Lite (CE Lite) is a software tool used to configure Eurotherm controllers. CE Lite employs a graphical user interface and drawing tools that allow you to create and diagram your configurations in an easy-to-understand format that represents the functionality of your configuration.

CE Lite can be used to configure a number of Eurotherm Drives products. Examples in this manual are for 590 and 590 + series drives.

DRIVE COMPATIBILITY

590 series, firmware version 3.2 or later; **590SP**, all firmware versions; **584S series**, firmware version 4.1 or later; **584SV** all firmware versions; **605 series**, all firmware versions; **620 series** firmware version 4.0 or later; **590 +** all firmware versions; **690 +** all firmware versions; and **650V** all firmware versions.

Key Features

Using CE Lite, you can:

- Create configurations for controllers;
- Install configurations into controllers;
- Modify configurations for controllers;
- Retrieve configurations from controllers.

WARNING!

Installing new configurations into a drive must only be done when the drive is in a stopped and safe condition. Errors in the configuration may cause unexpected and/or dangerous consequences in the control system. It is imperative that all configurations be checked and tested by a qualified engineer BEFORE installing them into drives and putting them into service.

OFF-LINE CONFIGURATION

You do not need drive hardware to create your system configurations using CE Lite. The entire system can be created off-line and installed into your drive. Once the configuration has been installed into your drive, changes can be made and re-installed while all the affected equipment is fully stopped.

COMPUTER COMPATIBILITY

CE Lite is designed to be used with computers equipped with:

- 386 processor or better;
- Microsoft® Windows™ operating system 95 / 98, Windows NT, Windows 2000, Windows XP;
- Minimum of 4 MB of RAM recognized by Windows (see your Windows manual);
- Minimum of 2 MB of hard drive space. More disk space may be needed as the number of configurations increases;
- Serial port for connecting the computer to the P3 port (similar to a telephone handset socket) on the drive;
- Windows-compatible mouse, trackball, or similar pointing device;
- UDP cable kit (Eurotherm Drives part number CM351909);
- VGA or higher resolution display. (This is recommended for viewing.);
- Laser printer. (This is recommended for printing your configurations.)

NOISE

Ground noise may disturb the P3 communications link. It is created by ground loops caused when both the computer and the drive are grounded. CE Lite has built-in retry mechanisms to deal with occasional electrical noise. Continuous noise, however, will cause extremely slow communications between the computer and the drive.

In systems with a large amount of electrical noise (for example, systems containing inverters) it may be necessary to break the ground loop to achieve usable communications. The ground loop can be broken by:

- Using a battery-powered notebook computer rather than a plug-in model since most notebook computers are not grounded;
- Installing an RS232 isolator module between the computer and the P3 socket.

WARNING!

Do not use any connectors, adapters, and/or cables other than those supplied by Eurotherm Drives. Failure to use materials supplied by Eurotherm Drives can result in severe damage to equipment and injury to personnel, and will void the Eurotherm Drives warranty.

Chapter 2 HANDLING

UNPACKING INSTRUCTIONS

Before you install and use ConfigEd Lite, verify the completeness of your package. Your ConfigEd Lite package should include:

- ConfigEd Lite product manual (part number RG352747);
- Installation disks containing the ConfigEd Lite program;
- UDP cable with 9 pin adapter (part number CM351909);
- User license for ConfigEd Lite.

If any item on this list is missing, contact the Eurotherm Drives Customer Service Department in your area. If the package or any of its contents is damaged, contact the shipper directly.

SPECIAL HANDLING

Proper care must be shown in the handling of the materials used for the program. The distribution disk should be kept in a clean, dry environment within a relatively constant range of temperature and humidity. Keep the ConfigEd Lite disk far from any sources of magnetism and electrical fields, including permanent magnet motors, as the magnetic or electrical fields may erase the information on the distribution disk.

WARNING!

ConfigEd Lite is a powerful software tool specifically designed to configure drives. Using ConfigEd Lite, it is possible to create potentially dangerous drive configurations. The user assumes all liability and risk for the performance, application, reliability, and safety of systems implemented using this tool. It is the responsibility of that user to understand the configurations thoroughly and check them independently prior to installation and operation of any equipment. Eurotherm Drives can accept no liability for the application of this software.

Chapter 3 INSTALLATION & SETUP

INSTALLATION PROCEDURE

With Windows launched, insert disk 1 type **a:setup** under **Start|Run** for Windows 95/98, NT, 2000 or XP. Then follow the prompts while setup guides you through the install process.

Detailed installation instructions for ConfigEd Lite are contained in the `readme.txt` file, displayed during setup.

Setup will ask you the folder in which you wish to install the program. The default is `CE_Lite`.

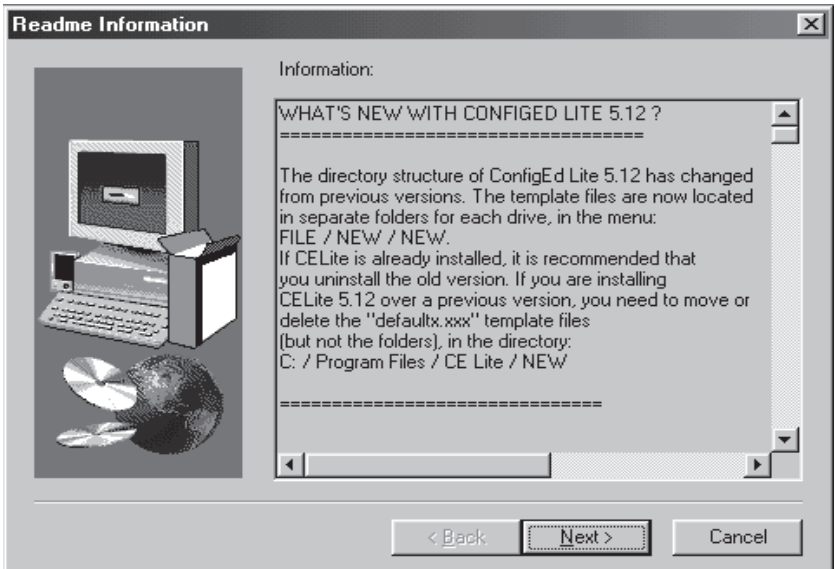

CE Lite

When setup has finished installing the program, the CE Lite icon will appear on your desktop.

Before using CE Lite the following items need to be completed prior to using.

1. In Windows install a local printer driver (cannot not be a network printer).
If a local printer driver is not installed, your PC will lock up while doing certain CE Lite operations.
2. In the properties of the local printer select “Spooling” to be “Print directly to printer” or “Raw”. If “EMF” is selected the configuration will not print correctly.
3. After launching, CE Lite will give a message saying there are no valid user settings. The program is looking for communication and printer settings. Default settings should work satisfactory.

Once these settings are completed CE Lite creates a user file to save these settings (celite.rct).

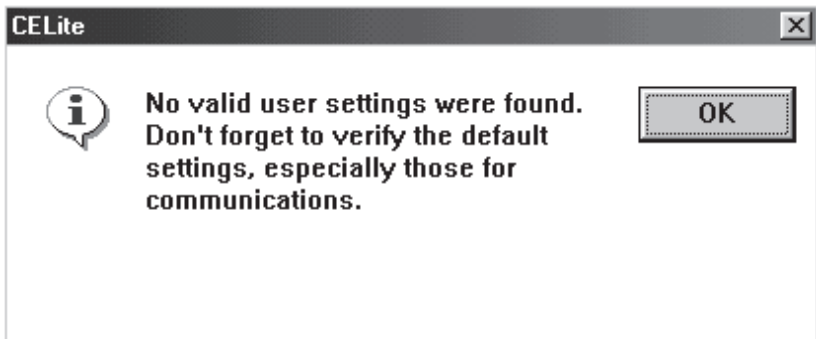

4. From the FILE menu, select PAGE SETUP.

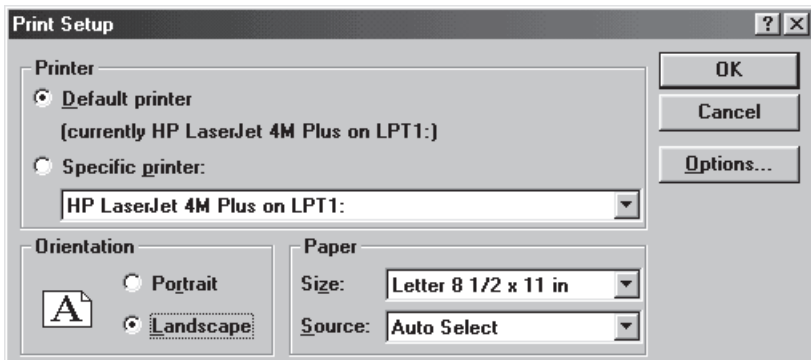

This brings up a window in which you may specify the printer you will be using and various options concerning the printing of your pages.

Since ConfigEd Lite creates drawings in a horizontal format, make sure your page is set for Landscape mode.

3. You should now set the communication parameters for the serial port connection between your computer and the drive to which it will be connected. From the Command menu, select Comms.

This brings up the Bisynch Master Setup dialog in which you set the port and baud rate of your drive connection.



Select a serial port (COM1, COM2, COM3, or COM4) and then select one baud rate (2400, 9600, 19200, 38400, or 57600). Be sure the serial port you select is not being used by other serial devices. If the mouse is connected to COM1, you would normally use COM2 for your drive connection.

It is recommended that you use 19,200 baud. Some computers may experience communication errors at 19,200 baud when using the standard Windows driver; the lower rates should reduce the errors. However, the 584SV, 605, 690+ and 650V will only communicate at 19,200 baud. Additionally older 590 and the 590+ drives will communicate best at 9600 baud.

CE Lite automatically creates a user file that contains these settings. CE Lite is now set up and ready to run. In the future when you launch CE Lite you will not be required to configure the printer and communication parameters. Launch ConfigEd Lite by double-clicking on the program icon.

COMMUNICATING WITH YOUR DRIVE

Eurotherm drives contain a serial port, similar to a telephone handset connector, for communicating with ConfigEd Lite equipped computers. This port is commonly referred to as the P3 port.

The keypad port is the serial port on 605 frames A and B, and 690+ frame B. The keypad needs to be removed to gain access to the port.

The P3 port on the 584SV is paralleled with the optional keypad it will be necessary to temporarily remove the optional keypad to establish serial communications.

WARNING!

Do not use any connectors, adapters, and/or cables other than those supplied by Eurotherm Drives. Failure to use materials supplied by Eurotherm Drives can result in severe damage to equipment and injury to personnel, and will void the Eurotherm Drives warranty.

PARAMETER SETTINGS

For a **590 and 590+ series** drive, set:

SERIAL LINKS::SYSTEM PORT::P3 SETUP::MODE to IPS (ASCII) or
CELITE (ASCII) and

SERIAL LINKS::SYSTEM PORT::P3 SETUP::P3 BAUD RATE to 19200.

For a **584S series** drive, set:

SERIAL LINKS::AUX PORT::ASCII/BINARY to ASCII and

SERIAL LINKS::AUX PORT::BAUD RATE to 19200.

For a **620 series** drive, set:

SERIAL LINKS::PORT P3::P3 MODE to EI ASCII and

SERIAL LINKS::PORT P3::BAUD RATE to 19200.

NOTE: For 590, 590+, 584S and 620 drives, the P3 BAUD RATE parameter may be set to other selections; however, it must match the communications settings chosen in ConfigEd Lite.

NOTE: If communications should fail to a 590 drive with firmware prior to version 4.2 the P3 port would lock-up. Cycling the control power to the drive will unlock the P3 port.

Chapter 4 CREATING A CONFIGURATION

OPENING A DEFAULT CONFIGURATION

From the File menu, select New : :New. This brings up a window with choices of drive types. Select the directory that contains the type of drive you will be configuring.

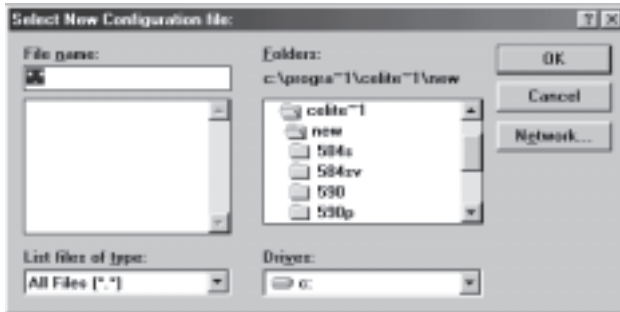

Select the 590P and ver 5 directories. Select default5.590 from the directory list and click on OK.

(NOTE: The number 5 is the firmware level of the drive and 590 is the model number. This format holds true for all default files. If you are working with a 690+, version 4, open **default4.690**).

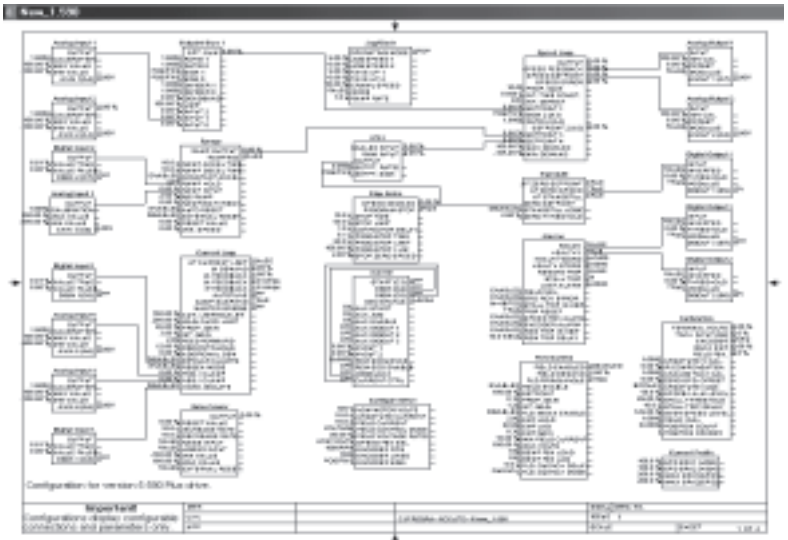

This brings up a graphical diagram of the default 590P drive configuration containing default function blocks and default connections.

DISPLAYING THE CONFIGURATION

There are a variety of Windows controls available to enhance viewing of the configurations. To enlarge the ConfigEd Lite window to fill your monitor screen, click on the zoom box in the upper right corner of the window. Clicking again on the box will return the window to its previous size.

Notice the gray outline frame near the bottom and right side of your ConfigEd Lite window. If the gray outline is not visible, try scrolling down or to the right until it appears. This frame marks the limits of the “page” on which your configuration is drawn. You must allow an extra margin inside the gray outline for the edges of the paper where the printer cannot print. Items extending beyond the gray outline will not print.

You can also re-size the ConfigEd Lite window by moving the mouse pointer to either an edge or a corner of the window until it changes into a two-pointed arrow. Then hold the left mouse key down as you drag the window edge to the size you want.

To get the configuration window to appear in the ConfigEd Lite window, press the Shift key while selecting the appropriate configuration from the Window menu. This is especially useful if you are using a small screen and the configuration you desire gets “lost” on your desktop.

You can enlarge or reduce the view inside the window from the keyboard by using the number keys (either at the top of the keyboard or on the numeric keypad), the + or - keys, or by choosing a different Scale size in the Draw menu. The arrow keys and the Page Up and Page Down keys modify the view of and/or move the drawing within the ConfigEd Lite window. For a complete list of keyboard commands, see the following table.

Keyboard Commands

Keystroke	Result
3	Scales to 3pt. font (0.50x drawing); homes drawing to upper left corner
4	Scales to 4pt. font (0.67x drawing); homes drawing to upper left corner
5	Scales to 5pt. font (0.83x drawing)
6	Scales to 6pt. font (1.00x drawing)
7	Scales to 7pt. font (1.17x drawing)
8	Scales to 8pt. font (1.33x drawing)
9	Scales to 9pt. font (1.50x drawing)
0	Scales to 10pt. font (1.67x drawing)
1	Scales to 11pt. font (1.83x drawing)
2	Scales to 12pt. font (2.00x drawing)
+	Increases scaling by factor of 1.33
-	Decreases scaling by factor of 1.33

Keystroke	Result
Home	Sets origin of view to upper left corner
Page Up	Moves view of drawing up by 7/8 of current size
Page Down	Moves view of drawing down by 7/8 of current size
Up arrow	Nudges view of drawing up
Down arrow	Nudges view of drawing down
Left arrow	Nudges view of drawing to the left
Right arrow	Nudges view of drawing to the right
Shift Page Up	Moves view of drawing to previous sheet
Shift Page Down	Moves view of drawing to next sheet
Backspace	Deletes currently-selected item

You may also use the mouse pointer to select an area of the drawing to enlarge. Determine the area of the drawing you want to enlarge, then hold down the mouse key as you “draw” a box around that area. When you release the mouse key, the area you have selected will fill the window. You must include a function block somewhere in the area you are selecting for this feature to work.

CONFIGURATION PARAMETERS

DISPLAYING PARAMETERS

To display the parameters of a particular function block, double-click on the block with your mouse. This brings up a window listing all the parameters for that function block. Connections are also shown in the parameters block.

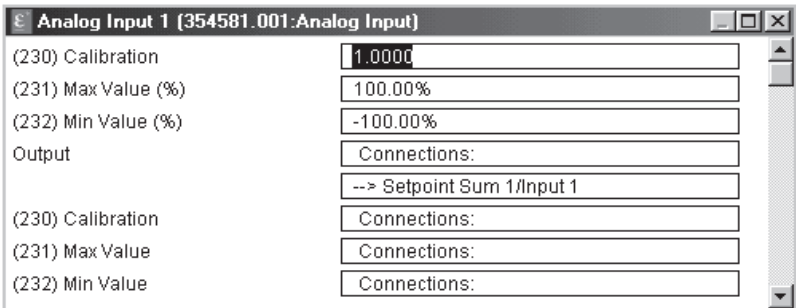

NOTE: Since all connections will be made on screen in graphical mode, the fields for connections are there for informational purposes only. Connections may not be set in this window.

CHANGING PARAMETERS

To change non-numeric parameters (for example, on/off or positive/negative), double-click on the appropriate field in the parameter function block window. A list of optional choices will appear from which you may choose your new parameter setting.

For a numeric field (for example, 0.500 seconds or 0.50%), click once on the field to highlight the numeric figure, then type in the new value to assign to the field.

When you are finished making your changes, close the parameters window to update and return to your configuration drawing.

MAKING CONNECTIONS

NOTE: Before creating any new or changing any existing connections in the default configuration, refer to the product manual for your drive.

Connections between function blocks (or in special cases between outputs and inputs on the same function block) are made by “drawing” the connection from an output on one block to an input on the other. To see how this is done, use the mouse to select and then enlarge your view of a pair of function blocks.

As you move the mouse pointer close to an output on one of the blocks, it will turn into a crosshair.

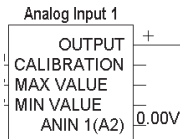

With the crosshair showing, click the mouse key once to make your initial connection with the output of the first function block. As you move the mouse away from the output connection, the crosshair turns back into a pointer and a dashed line follows the mouse's movement.

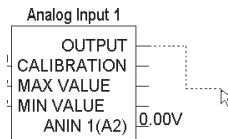

Make your way to an input connection on the second function block (or, in special cases, to the same function block). When you approach the connection, the pointer

will once again turn into a crosshair. Click on the input connection and the now solid line will extend from the output connection to the input connection.

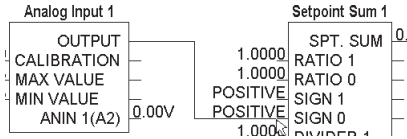

If you make a connection incorrectly, click on the connecting line. The line will become dashed. Press the Delete or Backspace key to delete the connection.

The routing of connection lines may also be adjusted to make the configurations easier to read. Click on the line you wish to move and drag the segment to the desired location. Its connections will remain intact but the line will follow the new path.

NOTE: Some function blocks (for example, analog and digital inputs) support only one connection per output. If you attempt to draw more than one connection from one of their outputs, the following error message will appear:

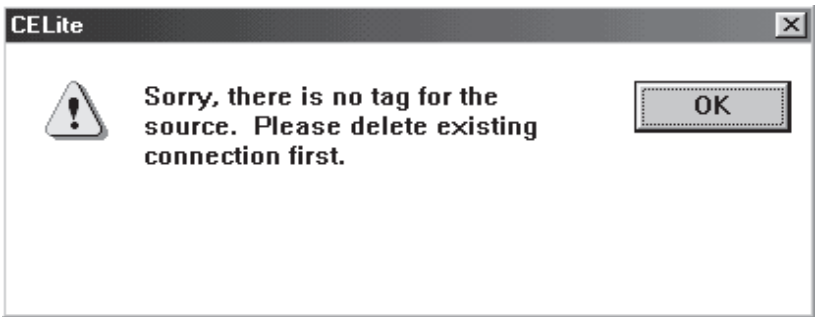

Delete a connection and proceed. This message may also appear if you exhaust the number of common connections allowed in a drive configuration. Special or dedicated connections are not included in this limit.

ALIGNING FUNCTION BLOCKS

You can move function blocks in your drawing to straighten out and neaten the appearance of your configuration even when they are connected. Place the mouse pointer on the object to be moved, hold down the mouse key, and drag it to its new location. When you are satisfied with its position, release the mouse key.

Aligning elements within your configuration drawing can be easily accomplished. To align a series of function blocks, either vertically or horizontally, click on the one in the position you plan to use as a master. Go to the Draw menu and select Align.

A check mark will appear next to `Align` to show that the alignment feature is operational. The alignment feature works on only the top or left side of the objects being aligned.

Select each element you want to align with the first, drag it to the general location you want, and release the mouse key. ConfigEd Lite will automatically snap it into alignment with the original element. ConfigEd Lite “senses” whether the most appropriate alignment is in the vertical or horizontal plane and moves the element accordingly. You can turn the alignment feature off by clicking on an empty section of the drawing (so no function block is selected) and selecting `Align` again. The check mark will now be gone, showing that the alignment feature is toggled off.

SAVING A CONFIGURATION

Once you have finished making changes and adjustments to the configuration, you must save it. If you have previously saved the configuration and wish to save it to the same name, select `Save` from the `File` menu. If this is the first time you are saving the configuration (for example, you selected `New` from the `File` menu to open the default configuration), you should select `Save As` from the `File` menu. This brings up a dialog box in which you name the configuration you are saving.

The default directory for saving new configurations is the `celite` directory. You should create additional directories in which to organize your configurations according to particular job needs. In this example, we have created a subdirectory called `new` in which we will save the `test_1.590` configuration. If you are unsure how to do this, consult your Windows manual.

Once you are in the correct directory, type in the new name for your configuration and click on the `OK` button to save it to that directory.

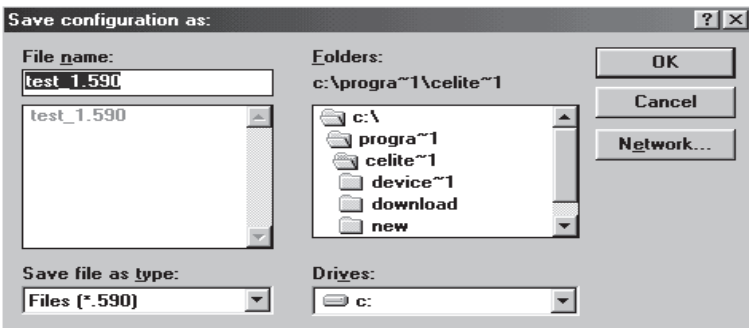

OPENING AN EXISTING CONFIGURATION

Once a configuration has been saved, ConfigEd Lite will display the configuration name in the File Open::Open. To open an existing configuration select the desired directory and configuration.

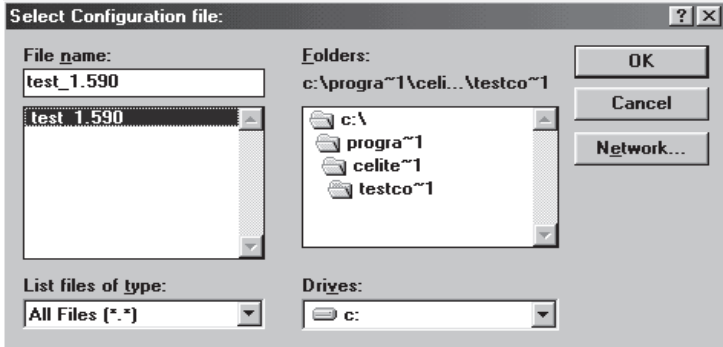

INSTALLING AND UPDATING CONFIGURATION

Once your configuration is completed and checked, it is ready to be installed into the drive. In order to install a configuration into a drive, the computer being used must be connected to that drive's P3 port. The P3 port mode must be set to ASCII and the baud rate must be set to match the ConfigEd Lite setting. See chapter 3, page 3 for drive-specific details.

WARNING!

Installing new configurations into a drive must only be done when the drive is in a stopped and safe condition. Errors in the configuration may cause unexpected and/or dangerous consequences in the control system. It is imperative that all configurations be checked and tested by a qualified engineer BEFORE installing them into drives and putting them into service.

NOTE: All other serial ports in the controller must be disabled before communicating through through the P3 port.

Use "Get Info"

To install a configuration into a drive, first open the configuration to be installed and make sure it is the selected configuration if more than one is open. Select **Get Info** from the **Command** menu to make sure the connection to the drive is good and the drive is not running. The results of your **Get Info** query will appear in the scratch pad as shown on the next page.

The example Scratch Pad indicates that CE Lite is connected to a 590 firmware version 5.16 (hex 5.10). The firmware version is indicated by using a hexadecimal number. Example firmware version 5.11 equals 5.B, 5.15 equals 5.F

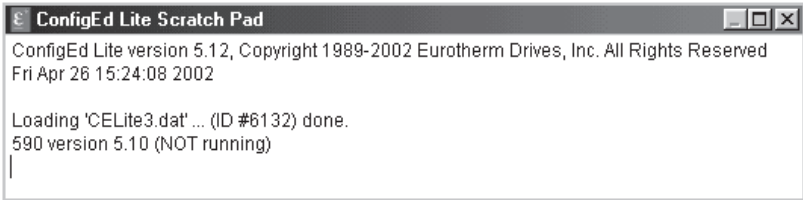

INSTALL CONFIGURATION

Select **Install** from the **Command** menu to begin the installation process.

The configuration is downloaded into the drive and the parameters set in the configuration replace those existing in the drive. A status box displays the progress of the **Install** procedure. When installing the configuration into a drive there are two selections, **FULL INSTALL** and **TYPICAL INSTALL**. Full install will load the application and all motor dependent parameters. **TYPICAL** install will load only application parameters. The configurations for following drives 590P, 590, 590SP and 584S do not contain any motor information, therefore a partial install is the only action available.

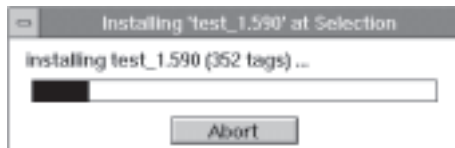
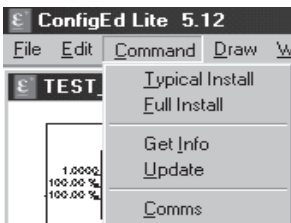

NOTE: When in doubt, always use the typical install to preserve motor and frame dependent parameters.

Updating a Configuration

The drive configuration and parameters can be retrieved from the drive by using the Update function in the Command menu.

Select Get Info from the Command menu to make sure the drive is connected. The results of your query will appear in the scratch pad.

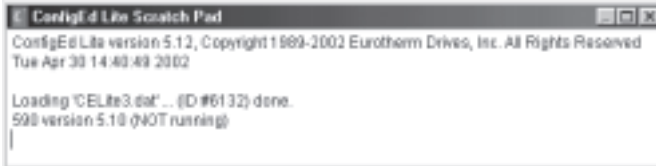

Open the configuration file you want to update, if it is not already open.

Select Update from the Command menu to replace the configuration parameters with those of the drive.

A status box displays the progress of the Update procedure.

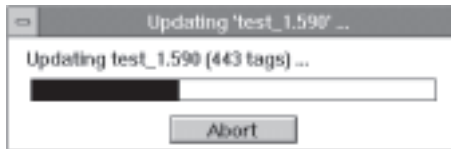

NOTE: The Update function will overwrite all the connections and parameter settings of the currently-selected configuration. Make sure you do not accidentally overwrite an unsaved configuration.

When the Update procedure is completed, save the configuration to preserve the updated parameters using either Save or Save As from the File menu.

CREATING CONFIGURATION TEMPLATES

Template files are useful for reusing configurations and creating standard graphical presentations. They are not overwritten when saving a configuration.

To create a template, open a configuration and modify it as needed. Select Save As in the File menu. Change the destination directory to \celite\new and choose OK to close the configuration file. This file will appear in the pop down menu when selecting New in the File menu.

PRINTING A CONFIGURATION

Once your page and printer setup are complete, you can print out a copy of your configuration in graphical mode by selecting Print from the File menu. Refer to Chapter 3, pages 3-2 and 3-3 for printer setup instructions.

Chapter 5 DOCUMENTING A CONFIGURATION

It is very helpful to have a printed reference list of configuration parameters and connections. This section shows you how to generate and print that list.

Document Your Configuration

To generate a listing of all parameters and connections in a configuration, first make sure the desired configuration is opened and selected. Then select Document from the File menu.

This brings up a dialog box in which you name the documentation file and assign it to a directory.

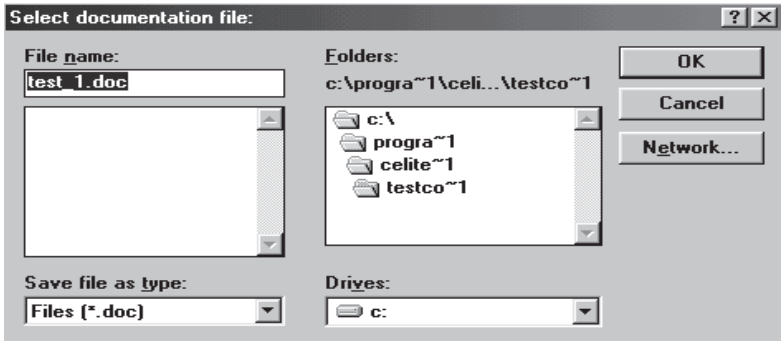

The default name is the same as the selected configuration with a .doc extension attached. The default directory is the same one that holds the selected configuration. Ensure that the name and directory are correct and click on the OK button to create the .doc file.

Review Your Documentation

The .doc file containing the configuration documentation may be opened by any word processor or text editor, including the Notepad® application bundled with Windows.

Launch your word processor or text editor and then select the .doc file for your configuration. (Example test_1.doc)

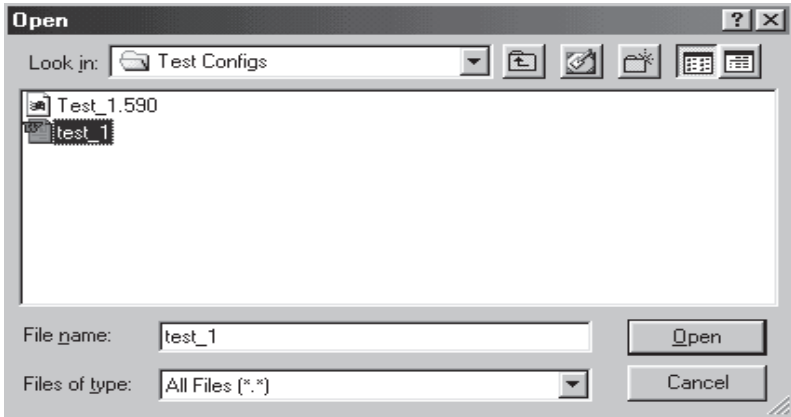

A listing of the configuration parameters will appear on screen.

```

test_1 - Notepad
File Edit Search Help
Parameters by Function Block:
Diagnostics
..{287} Speed Feedback (%) ..... 0.00% <READ-ONLY>
..{297} Speed Error (%) ..... 0.00% <READ-ONLY>
..{299} Current Demand (%) ..... 0.00% <READ-ONLY>
..{298} Current Feedback (%) ..... 0.00% <READ-ONLY>
..{ 87} Pos. 1 Clamp (%) ..... 0.0% <READ-ONLY>
..{ 88} Neg. 1 Clamp (%) ..... 0.0% <READ-ONLY>
..{ 67} Actual Pos 1 Lim (%) ..... 0.0% <READ-ONLY>
..{ 61} Actual Neg 1 Lim (%) ..... 0.0% <READ-ONLY>
..{ 82} Drive Start ..... OFF <READ-ONLY>
..{ 84} Drive Enable ..... Disabled
..{388} Field 1 Fbk. (%) ..... 0.00% <READ-ONLY>
..{388} Tach Input (82) (%) ..... -0.1% <READ-ONLY>
..{286} Encoder ..... 0RPM <READ-ONLY>
Ramps
..{ 85} Ramp Output (%) ..... 0.00% <READ-ONLY>
..{113} Ramping ..... False <READ-ONLY>
..{ 2} Ramp Accel Time (secs) ..... 10.0s
..{ 3} Ramp Decel Time (secs) ..... 10.0s
..{ 4} Constant Accel ..... Enabled
..{118} Ramp Hold ..... OFF
..{ 5} Ramp Input (%) ..... 0.00%
..{266} %S Ramp (%) ..... 2.50%
..{286} Ramping Thresh. (%) ..... 0.50%
..{287} Auto Reset ..... Enabled
..{288} External Reset ..... Disabled
..{422} Reset Value (%) ..... 0.00%
..{126} Min. Speed (%) ..... 0.00%

```

Print Your Documentation List

Once you have your configuration documentation open in a word processor or text editor, printing your configurations is simply a matter of sending it to a printer connected to your computer. Select **Print** from the **File** menu to send the .doc file to your printer.

Chapter 6 ADVANCED FEATURES

FORMS

An outline or border inserted around your configuration diagram provides a uniform, professional appearance when printed. Adding important text material can help make your diagrams clearer and more easily understood. ConfigEd Lite contains special drawing tools that let you design and produce your own forms and insert descriptive text. These forms (containing both graphical and text material) are stored as .frm files in ConfigEd Lite's working directory.

By now, you have learned that your configuration diagram must reside within the gray border that appears on your computer screen in order to be printed. When you add a custom form to your diagram, that form must also reside within the gray border. The form will appear on your screen and your diagram must then be placed within its borders to be printed.

NOTE: The gray border represents the page size, not the printable area. Make sure to leave a margin inside the border to suit your printer.

Create a Form

To create a custom form, you must be in a configuration window. You can either open an existing configuration or create a new one. For this demonstration, select **New :: 590P :: default5.590** from the **File** menu.



A new 590P drive configuration will appear on screen. You may now use the tools in the **Draw** menu to create your form.

NOTE: Sheet 0 is designed only for creating forms or adding information that will print on every page of the current configuration. Do not place items on sheet 0 that you do not want reproduced on every page in that configuration.

Go to the **Draw** menu and confirm you are on sheet 1. Forms are created on sheet 0, so select **Prev Sheet** to move to that sheet. You will be prompted with a dialog box asking if you want to edit the form. Click on **Edit**.

A new sheet will appear on screen. A gray border and title block will be visible on your page. Information can now be placed in this template that will appear on all sheets of your configuration. You should see a notation in the lower left corner that indicates the drive type/model number.

Text and objects maybe entered on this sheet. Text maybe added to the title block that will indicate the customer, revision, date, and other pertinent information.

A gray border should be visible, if it is not go to the Draw Scale menu and select a different magnification size. The gray border represents the size of the paper. If it is not in the landscape direction, go to the page setup to change from portrait to landscape.

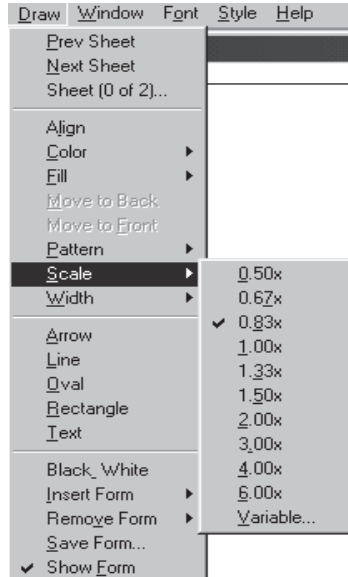

Automatic Data Entry

The title block will accept text coded to receive data automatically from your configuration specifications. The following table gives you the codes to enter to set up automatic data entry for your configuration diagram:

- ^C (the configuration name)
- ^D (the date of the last modification to the configuration)
- ^I (the directory in which the configuration resides)
- ^N (the number of sheets in the diagram)
- ^S (the current sheet number)

NOTE: Make sure you enter the codes exactly as they are given in the Format Code table. Case is critical. The caret (^) indicates formatting information for forms and text entered on sheet 0 and should not be used on other sheets.

For this exercise, we will use the blocks mentioned above. We will also create a block for your company name.

From the Draw menu, select the Rectangle tool (you can also create boxes for text by using the line tool, as we did for the form outline). Draw your blocks to the approximate size you will need. The size can be adjusted by dragging a corner of the box with the mouse pointer, so exactness is not essential at this point.

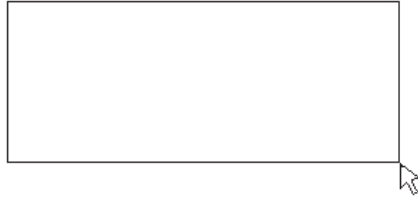

Start with a relatively large box for your company name. Since there is not a code format designed for the company name, that information will be added directly to the sheet, and thus become a permanent fixture on your configuration form sheets.

NOTE: You can de-select a drawing or text tool by clicking anywhere on the sheet. To continue using the same tool in a different location, hold down the `Ctrl` key as you click the mouse pointer. The same drawing or text tool that was last used will be repeated in the new location.

After the box is drawn, return to the `Draw` menu and select `Text`.

The pointer will turn into an `I`, signifying the placement point for text. Click the `I` tool where you want to begin adding text and type `Quality Systems, Inc.` (or your company name).



If the type you have entered looks too small, or you want to change the typeface or style, click on the type with the mouse pointer. You may have difficulty clicking on the type inside the box because, as was mentioned earlier, boxes created with the rectangle tool are filled. In that case, click once in the box and then go to the `Draw` menu and select `Move to Back`.

This action will shift the box to a layer behind the text block but still on the same sheet of the diagram. Click on the type block; a gray box will appear around the type.

Once selected, the type may be changed using the `Font` and `Style` menus. From the `Style` menu, choose 14 point bold type. Notice how the type changes.



Our box is too large for the type it surrounds. Move the mouse pointer to a corner of the box, hold the mouse key down, and re-size the box to fit the type better.

You can reposition boxes as well. Move the mouse pointer to the box, hold the mouse key down, and drag the box to the desired location. Create a series of boxes to hold the information you will need for your diagrams. Again, an enlarged view of the diagram area will help in drawing and aligning the boxes. Now you will enter the coded text that will import information from your configurations.

Decide which box will hold the configuration's name. For this exercise, we will use the top left box next to your company name. Select the **Text** tool and click once inside the box. Type the appropriate code, in this case `^C`.

To de-select the text function, click anywhere on the rest of the sheet. To continue adding text in another location, hold the **Ctrl** key down as you click the **I** tool in the new location. Using the **Ctrl** key and mouse click combination instructs the computer to repeat the last drawing tool selected. Proceed to designate boxes for the other codes listed at the beginning of this section. When you are finished, your boxes should look something like this:

<code>^C</code>	<code>^I</code>	
<code>^D</code>	<code>^N</code>	<code>^M</code>

Placing these codes instructs ConfigEd Lite to automatically insert the proper information for your configuration diagram, either on screen or when printing. Check to make sure that your information is in the correct block; if not, review each step carefully to find where you made a mistake.

NOTE: Holding down the **Ctrl** key when you click the mouse button retains the previous function and allows you to continue drawing or adding text, whichever was last done. In our example, the action will allow us to add a second line starting at the end point of the first. Continue drawing the other lines bordering your diagram area, connecting them at the corners by holding down the **Ctrl** key while clicking on the mouse key.

Once you have completed the design of your form and placed the coded text in the appropriate boxes, go to the **Draw** menu and select **Save Form**. A dialog window will ask you to name the form. Enter **Test** and click on the **OK** button.

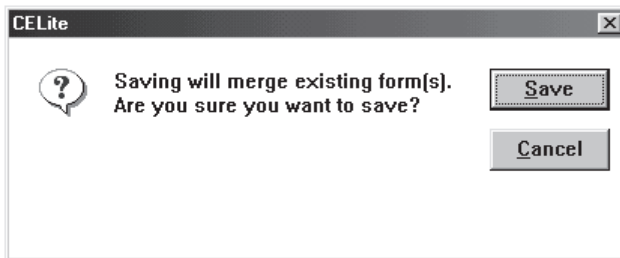

NOTE: If you have inserted a standard form into your configuration and then try to save it under another name, you will be asked to confirm that you want to merge the standard form into your new form.

A second window will tell you your form has been saved and the number of items (including the text boxes and coded type) processed.

Notice that `.frm` has been appended to the name of your form. This tells ConfigEd Lite to include it in the list of forms available for inserting into a diagram. Once you save a form, it can be added to any configuration diagram by going to the Draw menu, selecting `Insert Form`, and then selecting the form to insert.

You cannot have different forms for different sheets in the same multiple-sheet configuration. Only one form may be selected for each configuration. It is placed on sheet 0 and appears on every sheet of that configuration. Forms may be removed from configuration diagrams by going to the Draw menu, selecting `Remove Form`, and then choosing the form to be removed.

Selecting the `Show Form` menu item makes the form visible while working on the configuration and for printing. De-selecting `Show Form` can speed up screen redraws, which may be desired when modifying a diagram; however, it must be selected for the form to appear in the printout.

Chapter 7 TROUBLESHOOTING

Mismatched Baud Rates

The baud rates in the drive must match those in ConfigEdLite. Check the BAUD RATE setting on the drive under SERIAL LINKS. The 584SV, 605, 650V, and 690+ only communicate at 19,200 baud, which is also the default for ConfigEdLite.

Baud Rate Set Too High

Some computers may experience difficulty with the 19200 baud rate. For those computers, reduce the baud rate to 9600 on both, the drive as well as ConfigEdLite. (Remember, the 584SV, 605, 650V, and 690+ only communicate at 19,200 baud).

Wrong Communications Port

Another common error is trying to select a communications port already in use, typically by the mouse. Go to the Command Comms menu, select another communications port, and ensure your drive is connected to that port.

Drive P3 Mode Set Wrong

For a **590 and 590P series** drive, set:

```
SERIAL LINKS::SYSTEM PORT::P3 SETUP::MODE to IPS (ASCII) or CELITE (ASCII)  
SERIAL LINKS::SYSTEM PORT::P3 SETUP::P3 BAUD RATE to 9600.
```

For a **584S series** drive, set:

```
SERIAL LINKS::AUX PORT::ASCII/BINARY to ASCII  
SERIAL LINKS::AUX PORT::BAUD RATE to 19200.
```

For a **620 series** drive, set:

```
SERIAL LINKS::PORT P3::P3 MODE to EI ASCII  
SERIAL LINKS::PORT P3::BAUD RATE to 19200.
```

NOTE: For 590, 584S and 620 drives, the P3 BAUD RATE parameter may be set to other selections; however, it must match the communications settings chosen in ConfigEd Lite.

For **584SV, 605, 650 and 690+** drives, no special settings are required to communicate with CE Lite. The BAUD RATE in CE Lite must always be set at 19,200 for 584SV, 605, 650V and 690+.

Error Messages

Error detection is designed into ConfigEd Lite to help prevent the execution of an inappropriate or dangerous command. ConfigEd Lite displays error messages when it discovers a problem. The messages contain an error number and a brief description. Some messages also have an error code expressed as PNO plus a two-character code identifying the type of error. In case of irreconcilable errors, the error and code numbers may help the service technician help solve the problem.

The most common error messages you are likely to encounter are:

Code Error #6453 Serial Comms failed.	Action <ul style="list-style-type: none"> • Ensure drive has power and the cable is plugged into the correct correct serial port. • Set port in ASCII mode and ensure that baud rate of drive matches that of ConfigEdLite. If not, communications will resume only if the baud rate setting in the drive MMI is reset to match ConfigEdLite.
Description Serial comms has not responded as expected. PNO II, indicates that it failed to read ID (II).	<ul style="list-style-type: none"> • Group ID and Unit ID must be set to "0". • CONFIGURE I/O parameter must be "Disabled". • Check comport configuration. (COM 1, 3F8, IRQ4) (COM 2. 2F8, IRQ3)
Code Error #6449 Serial Comms failed.	Action <ul style="list-style-type: none"> • Reduce baud rate settings on drive and ConfigEdLite. (This is not possible for 584S, 605, 650V, & 690+ drives) • Reset the port by cycling power to the drive. • Cable damaged? Cable must not be longer than 10 feet. • Invalid destination tag.
Description Marginal or interrupted communications	
Code Error # 6405 Could not access configuration.	Action <ul style="list-style-type: none"> • Make sure the correct celite.dat file is in the same directory as your configurations.
Description Could not find the ".dat" file in the directory.	

Code	Description	Action
Error # 6463 Cannot install configuration while drive is running.	The drive must be stopped and disabled when you want to update the configuration with the parameters in the drive or install the configuration into the drive. The RUN/START signal must be off to use the Install command.	<ul style="list-style-type: none">Remove RUN/START signal.

Caution

This safety feature prevents dangerous consequences caused by modifying the operation of the drive while equipment is running.

Note

If CE Lite aborts during installation of the configuration, it is possible that an “anti-virus” program is running on the computer. Close the “anti-virus” program and try again.

Code	Description	Action
Error #6459 Could not open Serial Comms Library.	The Comms port on the computer is not active, turned off, or used by another device.	<ul style="list-style-type: none">Check comms port allocation and settings

Code	Description	Action
Error #6461 Wrong version firmware	Firmware version of the drive does not match the CELite configuration.	<ul style="list-style-type: none">Select the correct CE Lite configuration to match the drive version.

Code	Description	Action
Error #6597 Could not set tag 2201-1	Could not set tag number 201 to the regen mode.	<ul style="list-style-type: none">Select the correct mode of operation for the 590+power stack configuration. See “CURRENT LOOP” function block.Select the correct “P CODE” for the 590+ drive. Refer to the manual for instructions.

Chapter 8 REFERENCE

FUNCTIONBLOCKS

Function blocks are pre-configured elements providing processes required for configurations to be operational. All the function blocks necessary for the proper configuration of 590 series drives are included in the default .590 configuration supplied with ConfigEd Lite, as is true for all drives supported by ConfigEdLite.

INTER-SHEET CONNECTIONS

ConfigEd Lite allows you to draw connections between function blocks on different sheets. This is an important and valuable feature since drive configurations cover more than one sheet. To make inter-sheet connections:

1. Begin a connection from an output terminal of a function block on sheet1.
2. Move the mouse pointer to the Draw menu and select Next Sheet. You will see a dashed line for the connection attached to your mouse pointer. Holding the Shift key while pressing Page Down or Page Up will also allow you to change pages.



3. Complete the connection to an input terminal on the second function block. The dashed line will change to a solid line. It will be labeled with generic text identifying the connection and the source sheets (for example, ITEM 1 SHT 1).

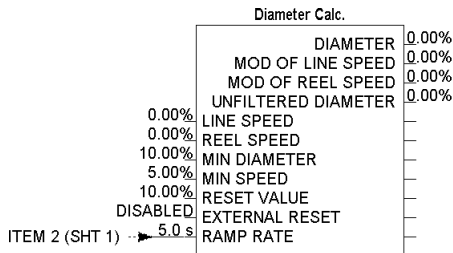

On the previous sheet, the text will show the destination sheet for the connection (for example, ITEM 1 SHT 2).

- Rename the connection by double-clicking on the arrow or the descriptive text to bring up a dialog box.



Enter the label you prefer. The new information will appear on both sheets.

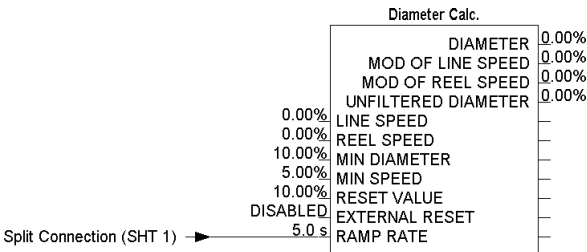

SPLIT CONNECTIONS

Similar to inter-sheet connections, split connections can help keep complex configurations from being cluttered with an abundance of crossing lines. Split connections resemble inter-sheet connections in that they include labels identifying their source and destination. Split connections may also be made in read-only configurations, since only the on-screen appearance has been modified and the connection itself has not been changed. To draw a split connection:

- Choose a connection between two distant function blocks.
- Double-click on the connection with the mouse pointer or click once and press the **Enter** key. A dialog box will ask for a name for the connection.



3. Enter the name and click the OK button. The connection will be split and labels will be attached to each end identifying the source and destination of the connection.

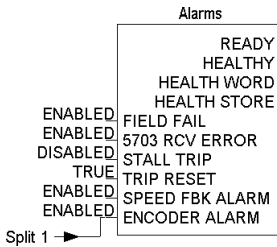

To change the connection name, double-click on either the connection or the label and enter the new information in the dialog box.

DRAWING

The ability to create configurations in a graphical display on screen is a key feature of ConfigEd Lite. The Draw menu contains a variety of tools to assist you in your work. It provides functions to move among multiple sheets of drawings, create custom outline forms, and annotate drawings with important information.

Additional commands in the Draw menu include *Oval*, *Color*, *Fill*, *Pattern*, and *Width*. These commands are used to modify objects drawn in or text added to the configuration. The color, fill, or width of the lines of function blocks and connecting lines cannot be modified. Only objects or lines you have drawn in a configuration can be modified with these tools.

To apply *Color*, *Fill*, *Pattern*, or *Width* commands to an existing object, select the object with the mouse pointer. As an example, we will use a box created in a blank configuration using the *Rectangle* tool. After creating the box, select it with the mouse pointer and then go to the draw menu and select *Pattern*.

A pop up list of pattern options will appear on screen; *Hollow* is the default pattern. Select a different pattern (for example, *Solid*) with the mouse and release the mouse key. The box will automatically be filled on screen. For illustration purposes, *Black* has been selected as the *Fill* color; the default fill is *White*.

The same sequence of steps can be used to modify the color of text or graphics, the width of lines (either alone or as part of a drawn object), and the fill of a drawn object.

NOTE: Pressing the `Ctrl` key after use of any drawing tool causes ConfigEd Lite to “remember” the last drawing action taken (whether drawing lines, arrows, or shapes, or adding text) and allows you to immediately repeat that action. This saves the time and effort of repeatedly selecting the tool from the `Draw` menu.

Drawing Tools

Color

The `Color` command is used to specify the outline color for rectangles and ovals and the display color for lines, arrows, and text you have added to your drawing.

To apply color to an object or text, either select a color and then a line or object to draw or text to place, or select an already-placed object or block of text and then change the color. The default color setting is `Black`.

Fill

The `Fill` command is used to color the contents of an object and highlight its appearance on a color display. To change the color for new objects, select `Fill` and choose the new color. All new objects will be drawn with that color.

To change the fill color of an existing object, select the object. Then select `Fill` and choose the new color. The default color is `White`.

Pattern

The `Pattern` command is used to set the fill pattern of an object. To change the fill pattern for new objects, select `Pattern` and choose the new style. All new objects will be drawn with that fill pattern.

To change the fill pattern of an existing object, select the object. Then select `Pattern` and choose the new fill pattern. The default `Pattern` setting is `Hollow`.

Width

The `Width` command is used to specify the thickness of lines created with the `Arrow`, `Line`, `Oval`, and `Rectangle` commands. One point is equal to $\frac{1}{72}$ of an inch. Line width ranges from 0.5 points to 16.0 points; the default line width is 0.5 points.

To get an idea of the differences in line widths, select the oval drawn previously and change the line using the `Width` tool. Notice the difference in the oval when the line is changed. The `Width` setting is also used for all newly-drawn objects.

Arrow

The `Arrow` command is a variant of the `Line` command. It is used to add lines with arrows to your drawings. Combined with text and other tools, arrows can be an effective tool to bring attention to a particular item.

Line

The `Line` command allows you to draw straight lines anywhere in your drawing. It can be used to create form outlines and text boxes, and to add highlighting to drawings. When you select `Line` from the `Draw` menu, your mouse pointer turns into an `X`, showing it is now a drawing tool. Place the `X` where you want to begin your line, press and hold the mouse key down, and drag a line to the desired end point.

Release the mouse key when your line is finished. To draw a series of connected lines, hold the `Ctrl` key down when you click the mouse the second time. A new line, starting where the first one finished, can then be dragged with the mouse.

Oval

The `Oval` command allows you to add an oval or circle to your drawing. When you create an oval on screen, the borders formed during the drawing process are rectangular. Only after you release the mouse key does the oval appear. When you select the oval to move it or modify its shape, it is highlighted by a rectangular gray box outlining its perimeter.

Rectangle

The `Rectangle` command allows you to add a rectangle to your drawing.

Text

The `Text` command allows you to add text to your drawing. It is covered in depth in Chapter 6.

DISPLAY OPTIONS

The `Scale` and `Black & White` display options are used to change the view of a configuration on your computer screen.

Scale

The `Scale` command is used to select the magnification ratio of your configuration display. The `Scale` menu presents a list of preset ratios as well as a `Variable` dialog function. The `Variable` dialog asks for a magnification setting within the range of .34x to 10x. The default `Variable` setting is the current viewing scale.

Keyboard commands may also be used to change scaling. See page 4-2 for a list of keyboard scaling commands.

Black & White

The `Black & White` command is used to switch the display of your configuration from color to black and white mode. This is useful when taking a drawing created on a color monitor and viewing it on a black and white monitor. It is also used when sending a color configuration to a black and white printer. With this command toggled on, it prevents printing the drawing in gray scale, which may result in poor printout quality.

ANNOTATING DRAWINGS

Objects and/or text may be added to your drawings in the same manner as is used for creating forms. The only difference is that such annotations are usually made on individual configuration sheets rather than on sheet 0.

Review the sections on using the drawing tools to add text or graphics to your configuration drawings.

SCRATCH PAD

The scratch pad provides a written record of your actions regarding the configurations, including loading, saving, and deleting drawings. That record is kept in the `celite.tex` file, which is created automatically when you first launch `ConfigEd Lite`. Every time the program is run, the information written to the scratch pad is added to the end of the `celite.tex` file. It is located in the working directory for the `ConfigEd Lite` icon, typically the `celite` directory. The `celite.tex` file may be edited using any text or word processing program that reads text files.

The scratch pad window appears on screen whenever `ConfigEd Lite` is launched. It responds to the same sizing commands and actions as any other `Windows™` element.

The launch time for `ConfigEd Lite` is recorded automatically in the scratch pad when the program opens. You can manually insert the current time at any point by selecting `Paste Time` from the `Edit` menu.

You can select the typeface and size for the information in the scratch pad by first making sure it is the active window. Next, go to the `Font` and `Style` menus and

select the typeface and size you prefer. The type in the scratch pad will change to the style you specified. The style selected for the scratch pad will also become the default for text you add to your configuration drawings, so choose it with care. A sans serif typeface, such as Helvetica, will be the clearest and easiest to read in your drawings and is recommended for that reason. Type that is automatically included with function blocks retains its default font regardless of the style chosen for the scratch pad.

To print out your ConfigEd Lite Scratch Pad records:

1. Launch a text editor or word processing program, such as the Windows™ Notepad®;
2. Select `Open` from the `File` menu;
3. Locate and open the `celite` directory;
4. Search for files with `.tex` in the file name;
5. Select `celite.tex` from the menu of files;
6. Select `Print` from the `File` menu once the file is opened.

You can also use the ConfigEd Lite Scratch Pad as a simple text editor to make notes on the actions recorded there. To add text manually, make sure that the scratch pad window is active and that you can see a blinking cursor. Then add whatever notations you wish by typing them in from the keyboard.

It is a good idea to edit your `celite.tex` file periodically, as it can grow quite large. Before deleting portions of the file or the entire file, make a copy (either printed or saved to a floppy disk) to retain for your records. This record is invaluable in tracking installations, modifications, and other actions regarding ConfigEd Lite.

You can either select portions of the file to delete while in your text editor or word processor or delete the entire file from your hard drive. If you delete the entire file, ConfigEd Lite will create a new `celite.tex` file the next time it is launched.

To clear the text displayed in the scratch pad window, make sure it is the active window and then choose `Save` from the `File` menu. This saves the text to disk and clears the on-screen display of the scratch pad information.

Chapter 9 APPENDIX

MENUS

File

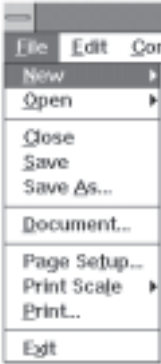

The File menu provides access to the New, Open, Close, Save, Save As, Document, Page Setup, Print Scale, Print, and Exit functions.

Edit



The Edit menu provides access to Cut, Copy, Paste, Clear, Select All, and Paste Time functions to be used in reference to the scratch pad.

Command



The Command menu provides access to the Install, Get Info, Update, and Comms functions.

Window



The Window menu provides access to the Parent, Child, and Sibling functions (a hierarchical order of window organization) as well as the Scratch Pad and any open configurations (in this example, default.590).

Font



The Font window provides access to the fonts available on your system for use in your configuration diagrams and in the scratch pad.

Style



The Style menu provides access to type style and size functions.

Help



The Help menu provides access to the About ConfigEd Lite information box and Template Help.

