

Line Drive/Master Ramp

This function block implements an S Ramp function with start/stop and status logic. It is intended to perform as a master ramp in a line drive system. A simplified block diagram is shown below; a detailed diagram is shown overleaf.

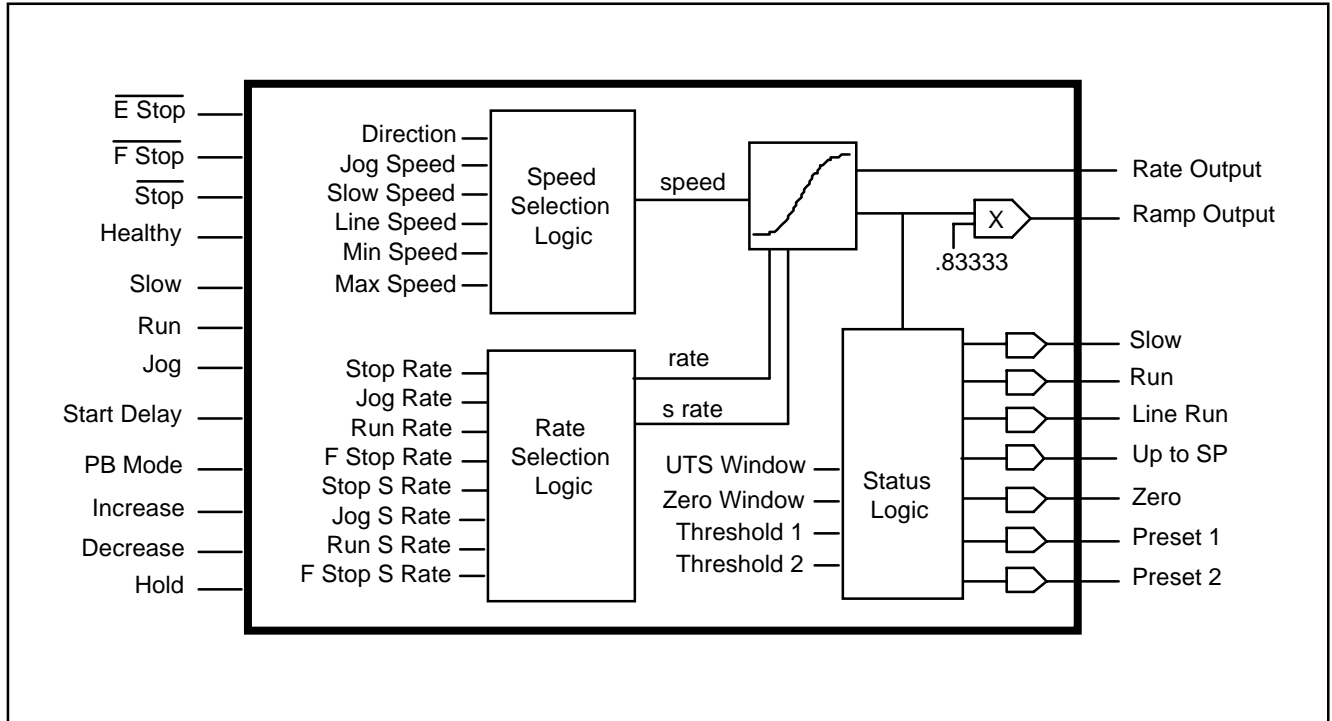

The **E Stop**, **F Stop**, **Stop** and **Healthy** inputs cause the ramp input to be set to zero whenever any of them are false (except in jog). If they are all true, **Jog**, **Slow** and **Run** will cause the ramp input to be set to **Jog**, **Slow** or **Line Speed**. If **PB Mode** and **Slow** are true, the ramp input will either be **Min** or **Max Speed**, which is selected by **Increase** and **Decrease**. If **Direction** is false, the sign of the input is changed. In **Jog**, **Slow** and **Run** modes, the ramp is initially held for **Start Delay** amount of time.

If **Hold** is true, the S Ramp is put into a hold state, setting the input to the output value. This causes the ramp to S to a hold value.

The ramp s rate and rate are selected by the Rate Selection Logic block. If **F Stop** is false, the F Stop rates are used. If run select is true, the Run rates are used. If jog select is true, the jog rates are used. Otherwise, the stop rates are used.

The **Line Run** output is set true when the **Jog**, **Slow** or **Run** are true and is reset when they are false and the ramp output is **Zero**. The **Zero** output is true when the absolute value of the ramp output is less than **Zero Window**. The **Up to SP** output is true when the absolute value of the difference between the ramp input and output is less than **UTS Window**. The **Preset 1** and **2** outputs are true when the absolute value of the ramp output is greater than **Threshold 1** and **2**.



Note that all logic outputs have built in senders, so no senders are needed when they are connected to the network.

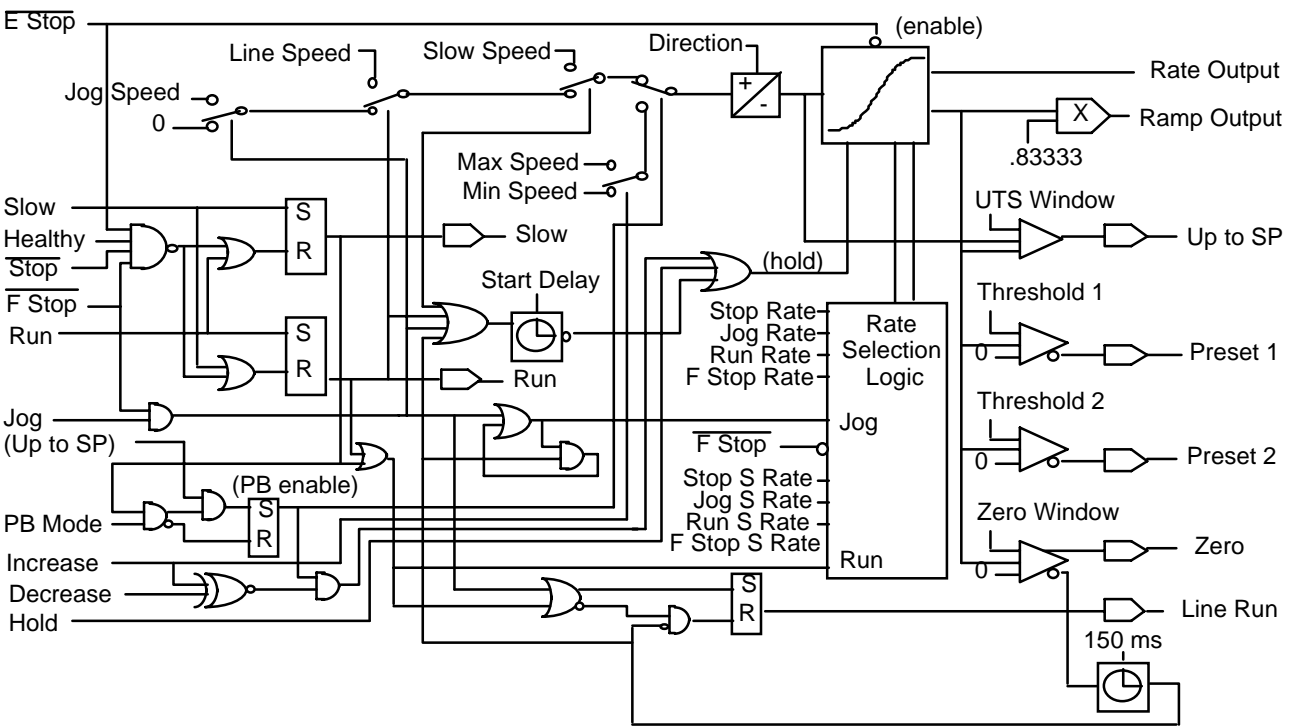



Operation	Description
E Stop	Emergency Stop. Stops when false.
F Stop	Fast Stop. Stops when false.
Stop	Normal Stop. Stops when false (unless in jog).
Healthy	Healthy state. Stops when false (unless in jog).
Jog	Jog input for the block. Expects Enabled (true) or Disabled (false).
Slow	Slowinput for the block. Expects Enabled (true) or Disabled (false).
Run	Run input for the block. Expects Enabled (true) or Disabled (false).
PB Mode	PB Mode input for the block. Expects Enabled (true) or Disabled (false).
Increase	Increase input for the block. Expects Enabled (true) or Disabled (false).
Decrease	Decrease input for the block. Expects Enabled (true) or Disabled (false).
Hold	Hold input for the block. Expects Enabled (true) or Disabled (false).
Direction	Direction input for the block. Expects Forward (true) or Reverse (false).
Start Delay	Sets timer delay time. Expects a value between 0.1 and 2000 seconds (100% = 2000 seconds).
Jog Speed	Set Jog ramp input speed. Expect a value (-100 to +100%).
Line Speed	Set Line ramp input speed. Expect a value (-100 to +100%).
Slow Speed	Set Slow ramp input speed. Expect a value (-100 to +100%).
Min Speed	Set Minimum ramp input speed. Expect a value (-100 to +100%).
Max Speed	Set Maximumramp input speed. Expect a value (-100 to +100%).
Stop Rate	Set the Stop ramp time for the ramp. Expect a value between 1 and 400 seconds. (100% = 3276.7 seconds).
Jog Rate	Set the Jog ramp time for the ramp. Expect a value between 1 and 400 seconds. (100% = 3276.7 seconds).
Run Rate	Set the Run ramp time for the ramp. Expect a value between 1 and 400 seconds. (100% = 3276.7 seconds).



F Stop Rate	Set the Fast Stop ramp time for the ramp. Expect a value between 1 and 400 seconds. (100% = 3276.7 seconds).
Stop S Rate	Set the Stop S time for the ramp. Expect a value between 0.1 and 5 seconds. (100% = 3276.7 seconds).
Jog S Rate	Set the Jog S time for the ramp. Expect a value between 0.1 and 5 seconds. (100% = 3276.7 seconds).
Run S Rate	Set the Run S time for the ramp. Expect a value between 0.1 and 5 seconds. (100% = 3276.7 seconds).
F Stop S Rate	Set the Fast Stop S time for the ramp. Expect a value between 0.1 and 5 seconds. (100% = 3276.7 seconds).
UTS Window	Sets Up to Setpoint input. Expects a value between 0 and 100%.
Zero Window	Sets Zero Window input. Expects a value between 0 and 100%.
Threshold 1	Sets Threshold 1 input. Expects a value between 0 and 100%.
Threshold 2	Sets Threshold 2 input. Expects a value between 0 and 100%.
Get E Stop	Returns the current state: Stopped when false.
Get F Stop	Returns the current state: Stopped when false.
Get Stop	Returns the current state: Stopped when false.
Get Healthy	Returns the current state: Healthy when true.
Get Jog	Returns the current state: Enabled (true) or Disabled (false).
Get Slow	Returns the current state: Enabled (true) or Disabled (false).
Get Run	Returns the current state: Enabled (true) or Disabled (false).
Get PB Mode	Returns the current state: Enabled (true) or Disabled (false).
Get PB Enable	Returns the current state: Enabled (true) or Disabled (false).
Get Increase	Returns the current state: Enabled (true) or Disabled (false).
Get Decrease	Returns the current state: Enabled (true) or Disabled (false).
Get Timer Input	Returns the current state: Enabled (true) or Disabled (false).
Get Timer Output	Returns the current state: Enabled (true) or Disabled (false).
Get Ramp Hold	Returns the current state: Holding (true) or Tracking (false).



Get Hold	Returns the current state: Holding (true) or Tracking (false).
Get Direction	Returns the current state: Forward (true) or Reverse (false).
Get Start Delay	Returns the current value in seconds (100% = 2000 seconds).
Get Jog Speed	Returns the current value: -100 to +100%.
Get Line Speed	Returns the current value: -100 to +100%.
Get Slow Speed	Returns the current value: -100 to +100%.
Get Min Speed	Returns the current value: -100 to +100%.
Get Max Speed	Returns the current value: -100 to +100%.
Get Input	Returns the current ramp input value: -100 to +100%.
Get Stop Rate	Returns the current value in seconds (100% = 3276.7 seconds).
Get Jog Rate	Returns the current value in seconds (100% = 3276.7 seconds).
Get Run Rate	Returns the current value in seconds (100% = 3276.7 seconds).
Get F Stop Rate	Returns the current value in seconds (100% = 3276.7 seconds).
Get Stop S Rate	Returns the current value in seconds (100% = 3276.7 seconds).
Get Jog S Rate	Returns the current value in seconds (100% = 3276.7 seconds).
Get Run S Rate	Returns the current value in seconds (100% = 3276.7 seconds).
Get F Stop S Rate	Returns the current value in seconds (100% = 3276.7 seconds).
Get UTS Window	Returns the current value: 0 to 100%.
Get Up to SP	Returns the current state.
Get Zero Window	Returns the current value: 0 to 100%.
Get Zero	Returns the current state.
Get Threshold 1	Returns the current value: 0 to 100%.
Get Preset 1	Returns the current state.



Get Threshold 2	Returns the current value: 0 to 100%.
Get Preset 2	Returns the current state.
Get Line Run	Returns the current state: Enabled (true) or Disabled (false).
Get Rate	Returns the current value.
Get Output	Returns the current value (unscaled): -100% to +100%.