



AC30V series Variable Speed Drive

HA501718U001 Issue 2
Product Manual

aerospace
climate control
electromechanical
filtration
fluid & gas handling
hydraulics
pneumatics
process control
sealing & shielding



ENGINEERING YOUR SUCCESS.

**FAILURE OR IMPROPER SELECTION OR IMPROPER USE OF THE PRODUCTS DESCRIBED HEREIN OR RELATED ITEMS
CAN CAUSE DEATH, PERSONAL INJURY AND PROPERTY DAMAGE.**

This document and other information from Parker Hannifin Corporation, its subsidiaries and authorized distributors provide product or system options for further investigation by users having technical expertise.

The user, through its own analysis and testing, is solely responsible for making the final selection of the system and components and assuring that all performance, endurance, maintenance, safety and warning requirements of the application are met. The user must analyze all aspects of the application, follow applicable industry standards, and follow the information concerning the product in the current product catalogue and in any other materials provided from Parker Hannifin Corporation or its subsidiaries or authorized distributors.

To the extent that Parker Hannifin Corporation or its subsidiaries or authorized distributors provide component or system options based upon data or specifications provided by the user, the user is responsible for determining that such data and specifications are suitable and sufficient for all applications and reasonably foreseeable uses of the components or systems.

The above disclaimer is being specifically brought to the user's attention and is in addition to and not in substitution to the Exclusions and Limitations on Liability which are set out in the terms and conditions of sale.

AC30V User's Manual

Frames D, E & F

HA501718U001 Issue 2

Compatible with Software Version 1.x onwards



2012 © Parker Hannifin Manufacturing Limited.

All rights strictly reserved. No part of this document may be stored in a retrieval system, or transmitted in any form or by any means to persons not employed by a Parker Hannifin Manufacturing Limited company without written permission from Parker Hannifin Manufacturing Ltd. Although every effort has been taken to ensure the accuracy of this document it may be necessary, without notice, to make amendments or correct omissions. Parker Hannifin Manufacturing Limited cannot accept responsibility for damage, injury, or expenses resulting therefrom.

WARRANTY

The general terms and conditions of sale of goods and/or services of Parker Hannifin Europe Sàrl, Luxembourg, Switzerland Branch, Etoy, apply to this contract unless otherwise agreed. The terms and conditions are available on our website: www.parker.com/termsandconditions/switzerland

Parker Hannifin Manufacturing Limited reserved the right to change the content and product specification without notice.

Contents	Page No.
Chapter 1: Safety	1-1
Requirements.....	1-1
Intended Users	1-1
Application Area.....	1-1
Personnel.....	1-2
Hazards	1-2
Chapter 2: Introduction	2-1
About this Manual.....	2-1
How the Manual is Organised	2-1
Initial Steps	2-2
PC Requirements	2-2
Equipment Inspection	2-3
Power Ratings.....	2-3
Packaging and Lifting Details	2-4
Chapter 3: Product Overview	3-1
Product Range	3-1
AC30V Frame D, E, F.....	3-1
Control Features.....	3-2
Functional Overview	3-3
Chapter 4: Installation	4-1
Cubicle Mount.....	4-1
Dimensions for Cubicle Mount Installation.....	4-1
Mounting the Drive.....	4-2
Ventilation.....	4-2
Cubicle Mounting Details (all frame sizes).....	4-3
Mounting Brackets.....	4-3
Through Panel Mount.....	4-4
Dimensions for Through Panel Installation	4-4
Mounting the Drive.....	4-5
Ventilation.....	4-5
Through Panel Mounting Details (all frame sizes).....	4-6
Cabling Bracket for Control & Main Cable.....	4-9
Electrical Installation.....	4-10
Wiring Instructions.....	4-10
Power Wiring Connections.....	4-11
Control Module Cover Removal.....	4-12
Control Module Removal	4-13
Control Wiring Connections.....	4-14
Wiring Diagrams	4-15

Contents	Page No.
Application 0: Basic Speed Control	4-15
Application 1: AUTO/MANUAL CONTROL	4-17
Application 2: Raise / Lower Trim	4-19
Application 3: Presets Speeds.....	4-21
Application 4: PID Control.....	4-23
Terminal Block Wire Range.....	4-25
Terminal Tightening Torques.....	4-26
Optional Equipment	4-26
Brake Wiring.....	4-26
Fitting a Remote GKP	4-27
Getting Started.....	4-28
GKP Setup Wizard	4-28
Ethernet Communications	4-29
Firmware Update.....	4-31
Updating the Drive firmware	4-31
Chapter 5: Associated Equipment.....	5-1
Main Points.....	5-1
AC Motor Chokes.....	5-1
AC Motor Chokes.....	5-2
Dynamic Braking Resistors.....	5-3
Wiring Details	5-3
Dynamic Braking Resistors.....	5-4
Resistor Selection.....	5-4
Circuit Breakers	5-6
External EMC Filters.....	5-6
Input Chokes	5-7
Gaskets.....	5-7
Cabling Bracket for Control & Main Cable.....	5-7
Option Cards	5-8
Installation Details	5-9
Chapter 6 Safe Torque Off SIL3/PLe.....	6-1
General Information.....	6-1
STO Functional Description.....	6-2
Alignment to European Standards	6-3
EN ISO13849-1:2008	6-3
EN61800-5-2:2007 and EN61508	6-4
Safety Specification.....	6-5
EMC Specification	6-5
User Connections	6-6
STO Technical Specification	6-8

2 Contents

Contents	Page No.
Inputs Specification	6-8
Output Specification	6-9
Truth Table.....	6-10
STO Input Timing Diagrams	6-11
Ideal Operation	6-11
Typical Operation	6-12
Fault Operation.....	6-13
Pulsed Inputs.....	6-14
STO State Transition Diagram.....	6-15
STO Trip Annunciation	6-15
STO Trip Annunciation	6-16
Safety Warnings and Limitations.....	6-17
Example User Wiring	6-19
Applications that do not require STO function.....	6-20
Minimum STO Implementation.....	6-21
STO Implementation with Safety Control Unit.....	6-22
SS1 Implementation using Safety Control Unit.....	6-24
STO Function Checking.....	6-26
Comprehensive Check.....	6-27
The following test steps must be performed:.....	6-28
Regular Check.....	6-32
Troubleshooting	6-33
Chapter 7: The Graphical Keypad	7-1
Overview.....	7-2
Keypad.....	7-3
The Display.....	7-4
Drive Status Summary.....	7-4
Soft key action indication.....	7-5
LEDS	7-5
The Menu System	7-6
Navigating the Menu System	7-6
Changing a Parameter Value.....	7-6
Trips and other Information displays	7-6
Chapter 8: Menu Organisation.....	8-1
Menu Map	8-1
Menu Map Summary	8-1
Menu Descriptions	8-2
Control Screen	8-2
Favourites	8-2
Update Firmware.....	8-3

Contents.....	Page No.
Setup.....	8-3
Advanced Setup.....	8-3
Monitor.....	8-3
Advanced Monitor.....	8-3
Parameters	8-3
Parameter Map.....	8-4
Chapter 9: Setup Wizard.....	9-1
GKP Setup Wizard	9-1
Parker Drive Quicktool (PDQ) PC Software	9-7
Installation	9-7
Starting the Wizard	9-9
Task selection	9-10
Find drive.....	9-11
Select Macro.....	9-12
Select motor	9-13
Setup the Drive Control.....	9-16
Setup I/O	9-17
Setup Communications.....	9-18
Commission the Drive	9-19
Monitor the Drive	9-20
Chapter 10: Trips & Fault Finding.....	10-1
Trips and Fault Finding.....	10-1
What Happens when a Trip Occurs.....	10-1
Resetting a Trip Condition	10-1
Using the Keypad to Manage Trips	10-2
Hexadecimal Representation of Trips.....	10-5
Runtime Alerts	10-6
Fault Finding	10-8
Chapter 11: Routine Maintenance & Repair.....	11-1
Routine Maintenance.....	11-1
Preventative Maintenance	11-1
Fan Cassette.....	11-1
DC Link Capacitors.....	11-2
Repair.....	11-2
Saving Your Application Data.....	11-2
Returning the Unit to Parker	11-2
Chapter 12: Ethernet.....	12-1
Introduction.....	12-1
Connecting to a Network	12-1

Contents	Page No.
Recommended Cable.....	12-1
Status Monitoring.....	12-2
Setting the IP Address	12-2
Typical Wiring Configurations	12-4
Web (HTTP) Server	12-6
Web Pages.....	12-6
Troubleshooting the Web Server.....	12-7
Troubleshooting	12-8
Flashing GKP icon.....	12-8
An IP Address is set but there is No Communication.....	12-9
Link Detection	12-9
Changing the PC Ethernet settings	12-10
Parameter Summary.....	12-11
Parameter Summary.....	12-11
Appendix A: Modbus TCP	A-1
Introduction.....	A-1
Modbus Register Mapping.....	A-1
Arrays.....	A-2
Strings.....	A-3
Supported Modbus Functions.....	A-5
Read Holding Registers (#3)	A-5
Read Input Registers (#4)	A-5
Write Single Register (#6).....	A-5
Write Multiple Registers (#16)	A-5
Modbus Exception Codes.....	A-6
Illegal Function (01).....	A-6
Illegal Data Address (02).....	A-6
Illegal Data Value (03)	A-6
Process Active and Lost Communications Trip.....	A-6
Process Active Flag	A-6
Trip	A-6
Parameter Summary.....	A-7
Appendix B: Sequencing Logic	B-1
Drive State Machine	B-1
DS402	B-1
Sequencing State	B-1
Sequencing Diagram.....	B-2
State Transitions	B-3
Control Word	B-5
Status Word	B-6

Contents	Page No.
Appendix C: Compliance	C-1
Applicable Standards	C-1
EUROPEAN COMPLIANCE	C-2
CE Marking	C-2
EMC Compliance.....	C-3
EMC Standards Comparison	C-4
Radiated.....	C-4
Conducted Emission	C-5
AC30V EMC Compliance (4kHz)	C-6
EMC Installation Guidance	C-9
Protective Earth (PE) Connections.....	C-9
Mitigating Radiated Emissions	C-10
Cabling Requirements	C-12
Internal Filter Disconnection.....	C-18
Harmonic Information	C-21
Requirements for North American and Canadian Compliance C-24	
North American Compliance.....	C-24
Canadian Compliance	C-25
North American and Canadian Compliance Information.....	C-25
Environmental.....	C-28
Restriction, Evaluation, Authorisation and Restriction of Chemicals (REACH)	C-28
Restriction of Hazardous Substances (RoHS)	C-28
Waste Electrical and Electronic Equipment (WEEE)	C-29
Appendix D: Parameter Reference	D-1
Parameter Descriptions	D-1
Autotune	D-2
BACnet IP	D-4
BACnet MSTP.....	D-5
Braking	D-6
CANopen.....	D-7
CC Link	D-8
Comms.....	D-9
Control Mode.....	D-10
ControlNet	D-11
Current Limit	D-12
Device Commands.....	D-13
DeviceNet.....	D-14
Drive info	D-15
Energy Meter	D-16
EtherCAT	D-17
Ethernet	D-18

4 Contents

Contents	Page No.
EtherNet IP	D-19
Event	D-20
Feedbacks	D-21
Fluxing VHz	D-23
Flycatching	D-27
General Purpose IO	D-29
Graphical Keypad	D-30
Induction Motor Data	D-32
Inj Braking	D-33
IO Configure	D-34
IO Option Common	D-35
IO Values	D-36
Local Control	D-38
Minimum Speed	D-39
Modbus	D-40
Modbus RTU	D-41
Modbus TCP	D-42
Motor Load	D-43
Motor Nameplate	D-46
Option Ethernet	D-47
Pattern Generator	D-48
PID	D-49
PMAC Flycatching	D-51
PMAC Motor Data	D-52
PMAC SVC	D-54
Preset Speeds	D-61
Profibus DP-V1	D-63
PROFINET IO	D-64
Raise Lower	D-65
Ramp	D-67
Read Process	D-72
Real Time Clock	D-73
Scale Setpoint	D-74
Sequencing	D-75
Setup Wizard	D-77
Skip Frequencies	D-78
Slew Rate	D-81
Slip Compensation	D-82
Soft Menus	D-83
Spd Direct Input	D-84
Spd Loop Diagnostics	D-85
Spd Loop Settings	D-86
Speed Ref	D-89
Stabilisation	D-90

Contents	Page No.
Stack Inv Time	D-91
Stall Trip	D-93
Torque Limit	D-94
Trips History	D-96
Trips Status	D-97
Voltage Control	D-98
Web Server	D-99
Write Process	D-100
Parameter Table	D-101
Table of Parameters in Alphabetical Order	D-124
Appendix E: E Plan Library	E-1
E Plan Library	E-1
Appendix F: Technical Specifications	F-1
Understanding the Product Code	F-1
Model Number	F-1
Environmental Details	F-2
Earthing/Safety Details	F-3
Internal Cooling Fans	F-3
Electrical Ratings (400V Build Variant)	F-4
Input Fuse Ratings (Europe)	F-6
Input Fuse Ratings (North America and Canada)	F-6
FRAME D Internal Dynamic Brake Switch	F-7
FRAME E Internal Dynamic Brake Switch	F-7
FRAME F Internal Dynamic Brake Switch	F-7
Supply Short Circuit Rating	F-8
Analog Inputs/Outputs	F-9
Reference Outputs	F-9
Digital Inputs	F-10
Digital Outputs	F-10
User 24v Supply (X13/05)	F-11
Relays	F-11

Chapter 1: Safety



Safety Information

IMPORTANT Please read these important Safety notes before installing and operating this equipment

CAUTION

CAUTION notes in the manual warn of danger to equipment.

WARNING

NOTES IN THE MANUAL WARN OF DANGER TO PERSONEL

Requirements

INTENDED USERS

This manual is to be made available to all persons who are required to install, configure or service equipment described herein, or any other associated operation.

The information given is intended to highlight safety issues, and to enable the user to obtain maximum benefit from the equipment. Complete the following table for future reference detailing how the unit is to be installed and used.

INSTALLATION DETAILS			
Model Number <i>(see product label)</i>		Where installed <i>(for your own information)</i>	
Unit used as a: <i>(refer to Certification)</i>	<input type="checkbox"/> Component <input type="checkbox"/> Relevant Apparatus	Unit fitted:	<input type="checkbox"/> Cubicle mounted <input type="checkbox"/> Through Panel Mounted

APPLICATION AREA

The equipment described is intended for industrial motor speed control utilising AC induction motors or AC permanent magnet synchronous machines.

1-2 Safety

PERSONNEL

Installation, operation and maintenance of the equipment should be carried out by competent personnel. A competent person is someone who is technically qualified and familiar with all safety information and established safety practices; with the installation process, operation and maintenance of this equipment; and with all the hazards involved.

 DANGER Risk of electric shock	 WARNING Hot surfaces	 Caution Refer to documentation	 Earth/Ground Protective Conductor Terminal
---------------------------------------------------------------------------------------------------------------------------	------------------------------------------------------------------------------------------------------------------	------------------------------------------------------------------------------------------------------------------------------	------------------------------------------------------------------------------------------------------------------------------------------

HAZARDS

DANGER! - Ignoring the following may result in injury

1. This equipment can endanger life by exposure to rotating machinery and high voltages.
2. The equipment must be permanently earthed due to the high earth leakage current, and the drive motor must be connected to an appropriate safety earth.
3. Ensure all incoming supplies are isolated before working on the equipment. Be aware that there may be more than one supply connection to the drive.
4. There may still be dangerous voltages present at power terminals (motor output, supply input phases, DC bus and the brake, where fitted) when the motor is at standstill or is stopped.
5. For measurements use only a meter to IEC 61010 (CAT III or higher). Always begin using the highest range. CAT I and CAT II meters must not be used on this product.
6. Allow at least 5 minutes for the drive's capacitors to discharge to safe voltage levels (<50V). Use the specified meter capable of measuring up to 1000V dc & ac rms to confirm that less than 50V is present between all power terminals and between power terminals and earth.
7. Unless otherwise stated, this product must NOT be dismantled. In the event of a fault the drive must be returned. Refer to "Routine Maintenance and Repair".

WARNING! - Ignoring the following may result in injury or damage to equipment**SAFETY**

Where there is conflict between EMC and Safety requirements, personnel safety shall always take precedence.

- Never perform high voltage resistance checks on the wiring without first disconnecting the drive from the circuit being tested.
- Whilst ensuring ventilation is sufficient, provide guarding and /or additional safety systems to prevent injury or damage to equipment.
- When replacing a drive in an application and before returning to use, it is essential that all user defined parameters for the product's operation are correctly installed.
- All control and signal terminals are SELV, i.e. protected by double insulation. Ensure all external wiring is rated for the highest system voltage.
- Thermal sensors contained within the motor must have at least basic insulation.
- All exposed metalwork in the Inverter is protected by basic insulation and bonded to a safety earth.
- RCDs are not recommended for use with this product but, where their use is mandatory, only Type B RCDs should be used.

EMC

- In a domestic environment this product may cause radio interference in which case supplementary mitigation measures may be required.
- This equipment contains electrostatic discharge (ESD) sensitive parts. Observe static control precautions when handling, installing and servicing this product.
- This is a product of the restricted sales distribution class according to IEC 61800-3. It is designated as "professional equipment" as defined in EN61000-3-2. Permission of the supply authority shall be obtained before connection to the low voltage supply.

WARNING! – Control Unit Removal / Fitting

Isolate supply before plugging or unplugging control unit to the power stack.

CAUTION!

APPLICATION RISK

- The specifications, processes and circuitry described herein are for guidance only and may need to be adapted to the user's specific application. We can not guarantee the suitability of the equipment described in this Manual for individual applications.

RISK ASSESSMENT

Under fault conditions, power loss or unintended operating conditions, the drive may not operate as intended. In particular:

- Stored energy might not discharge to safe levels as quickly as suggested, and can still be present even though the drive appears to be switched off
- The motor's direction of rotation might not be controlled
- The motor speed might not be controlled
- The motor might be energised

A drive is a component within a drive system that may influence its operation or effects under a fault condition. Consideration must be given to:

- Stored energy
- Supply disconnects
- Sequencing logic
- Unintended operation

Chapter 2: Introduction

About this Manual

IMPORTANT *Motors used must be suitable for Inverter duty.*

NOTE Do not attempt to control motors whose rated current is less than 25% of the drive rated current. Poor motor control or Autotune problems may occur if you do.

This manual is intended for use by the installer, user and programmer of the AC30V drive. It assumes a reasonable level of understanding in these three disciplines.

NOTE Please read all Safety information before proceeding with the installation and operation of this unit.

It is important that you pass this manual on to any new user of this unit.

HOW THE MANUAL IS ORGANISED

This Engineering Reference manual is organised into chapters, indicated by the numbering on the edge of each page. If the manual is to be printed it is designed so that it should be printed double-sided using the short-edge for binding.

Information for all AC30V units is included, (frames D, E & F).

Parker Hannifin Manufacturing Limited is referred to as “Parker” throughout the manual.

The manual is more detailed than the relevant QuickStart manual, and so is of use to the unfamiliar as well as the high-end user.

2-2 Introduction

INITIAL STEPS

Use the manual to help you plan the following:

Installation

Know your requirements:

- certification requirements, CE/UL/CUL conformance
- conformance with local installation requirements
- supply and cabling requirements

Operation

Know your operator:

- how is it to be operated, local and/or remote?
- what level of user is going to operate the unit?
- decide on the best menu level for the Keypad (where supplied)

Programming (Parker Drive Quicktool) – pc programming tool

Know your application:

- Install the Parker Drive Quicktool (PDQ) from your cd and check for updates at www.parker.com/ssd/pdq
- Connect your pc to your Drive via Ethernet
- Commission your Drive with the Parker Drive Quicktool wizard
- Go to Appendix D Parameter Reference for more information

PC REQUIREMENTS

Minimum system requirements:

- 1GB RAM
- 1GHz Pentium
- 1GB free Hard Disk space
- 1024x768 screen resolution

Operating Systems:

- Windows XP
- Windows Vista (32 bit)
- Windows 7 (32 & 64 bit)

Equipment Inspection

- ◆ Check for signs of transit damage
- ◆ Check the product code on the rating label conforms to your requirement.

If the unit is not being installed immediately, store the unit in a well-ventilated place away from high temperatures, humidity, dust, or metal particles.

Storage and Shipping Temperatures			
Storage Temperature :	-25°C to +55°C	Shipping Temperature :	-25°C to +70°C

Power Ratings

Order Code	Normal Duty Ratings			Heavy Duty Ratings			Frame
	kW/HP	Output Current A_{rms}		kW/HP	Output Current A_{rms}		
		400 VAC	480 VAC		400 VAC	480 VAC	
380-480 ($\pm 10\%$) VAC Supplies Three Phase							
31V-4D0004-B●-■◆-0000	1.1/1.5	3.5	3.0	0.75/1	2.5	2.1	D
31V-4D0005-B●-■◆-0000	1.5/2	4.5	3.4	1.1/1.5	3.5	3.0	D
31V-4D0006-B●-■◆-0000	2.2/3	5.5	4.8	1.5/2	4.5	3.4	D
31V-4D0008-B●-■◆-0000	3/4	7.5	5.8	2.2/3	5.5	4.8	D
31V-4D0010-B●-■◆-0000	4/5	10	7.6	3/4	7.5	5.8	D
31V-4D0012-B●-■◆-0000	5.5/7.5	12	11	4/5	10	7.6	D
31V-4E0016-B●-■◆-0000	7.5/10	16	14	5.5/7.5	12	11	E
31V-4E0023-B●-■◆-0000	11/15	23	21	7.5/10	16	14	E
31V-4F0032-B●-■◆-0000	15/20	32	27	11/15	23	21	F
31V-4F0038-B●-■◆-0000	18/25	38	36	15/20	32	27	F

●	EMC Filter Options
N	No filter
F	C2 filter
E	C3 filter
■	Graphical Keypad Options
2	Graphical Keypad
1	Keypad Blanking Cover
0	No Keypad
◆	Environmental Protection Options
S	Standard Coating
E	Enhanced Coating

Packaging and Lifting Details

Caution

The packaging is combustible. Igniting it may lead to the generation of lethal toxic fumes.

- ◆ Save the packaging in case of return. Improper packaging can result in transit damage.
- ◆ Use a safe and suitable lifting procedure when moving the unit. Never lift the unit by its terminal connections.
- ◆ Prepare a clear, flat surface to receive the drive before attempting to move it. Do not damage any terminal connections when putting the unit down.

Chapter 3: Product Overview

Product Range AC30V FRAME D, E, F

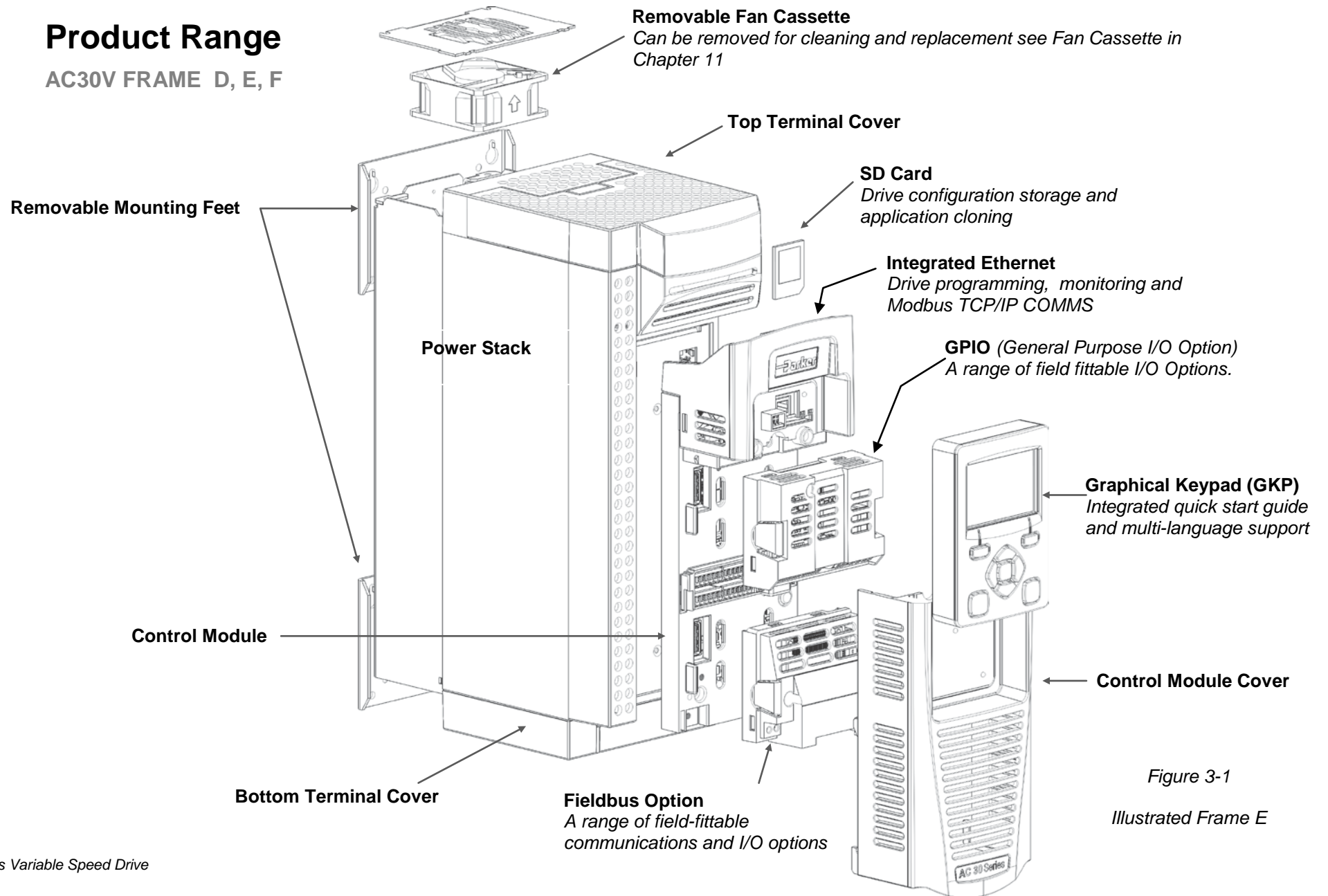

Figure 3-1

Illustrated Frame E

3-2 Product Overview

Control Features

The drive is fully featured when controlled using the optional Keypad (or a suitable pc programming tool).

The 'General' control features below are not user-selectable when the unit is controlled using the analog and digital inputs and outputs.

General	Output Frequency	Selectable 0 – 500Hz
	Switching Frequency	4 – 16 kHz
	Voltage Boost	0-25%
	Motor Control Modes	Induction motor VHz or Sensorless Vector Control (with autotune) PMAC motor – Sensorless Vector Control
	Skip Frequencies	Skip frequencies with adjustable skip band width
	Preset Speeds	User selectable preset speeds
	Stopping Modes	Ramp, Coast, DC Injection, Quickstop
	S Ramp and Linear Ramp	Symmetric or asymmetric ramp up and down rates
	Raise/Lower	Programmable MOP function
	Jog	Programmable jog speed
	Diagnostics	Full diagnostic and monitoring facilities
Protection	Trip Conditions	Output short line to line, and line to earth Overcurrent > 220% Stall Heatsink overtemperature Motor Thermistor overtemperature (using optional GPIO) Overvoltage and undervoltage
	Current Limit	Adjustable 110% (Normal Duty) or 150% (Heavy Duty) 180% shock load limit (Heavy Duty) Inverse Time
	Dual Rating	Normal duty (110% overload for 60s) Heavy duty (150% overload for 60s)
Inputs/Outputs	Analog Inputs	2 configurable inputs; voltage or current
	Analog Outputs	2 configurable outputs; voltage or current
	Digital Inputs	3 configurable 24V dc inputs
	Digital I/O	4 configurable 24V dc open collector outputs/digital inputs
	Relay Outputs	2 configurable relay output

Table 3-1 Control Features

Functional Overview

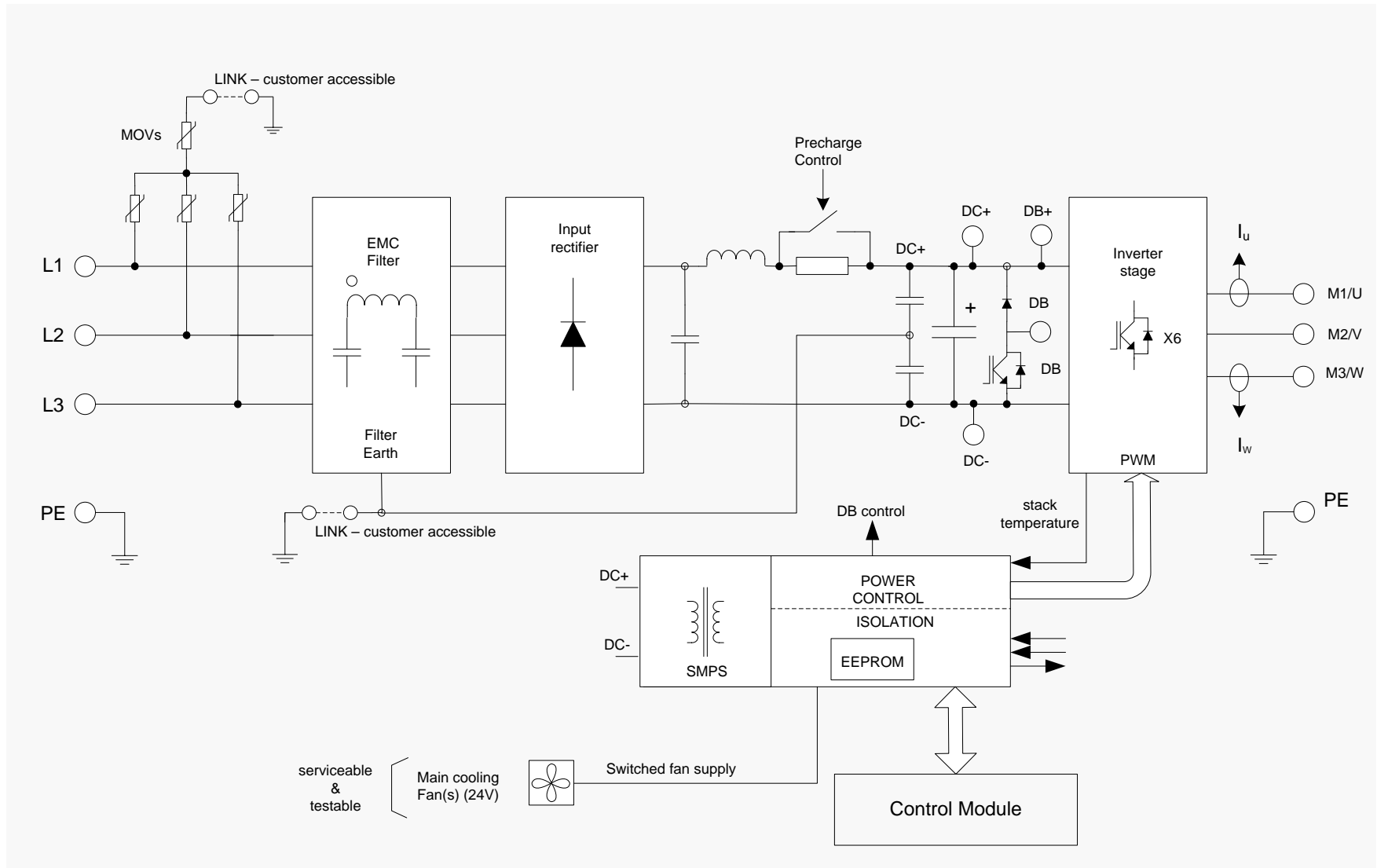

Block Diagram for Frames D, E, F

4-1 Installation

Chapter 4: Installation

IMPORTANT Read Appendix C: “Compliance” before installing this unit.

Cubicle Mount

DIMENSIONS FOR CUBICLE MOUNT INSTALLATION

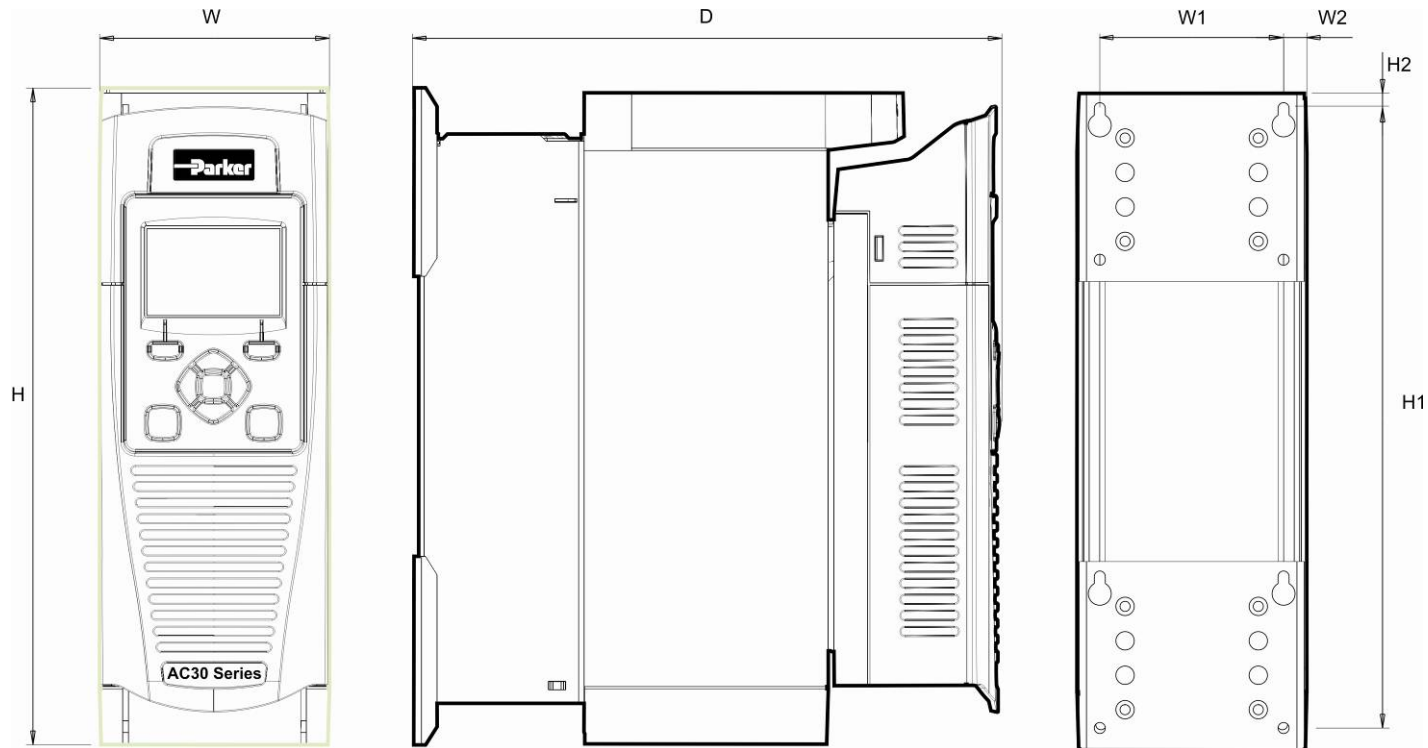

Figure 4-1 Mechanical Dimensions for AC30V Drive - Frame D Illustrated

Models	Max. Weight	H	H1	H2	W	W1	W2	D	Fixings
Frame D	4.5 kg (10 lbs)	286.0 (11.26)	270.0 (10.6)	6.5 (0.25)	100.0 (3.93)	80.0 (3.15)	10.0 (0.39)	255.0 (10.0)	Slot 4.5mm wide Use M4 fixings
Frame E	6.8 kg (15 lbs)	333.0 (13.11)	320.0 (12.6)	6.5 (0.25)	125.0 (4.92)	100.0 (3.93)	12.5 (0.49)	255.0 (10.0)	
Frame F	10.0 kg (22 lbs)	383.0 (15.07)	370.0 (14.5)	6.5 (0.25)	150.0 (5.90)	125.0 (4.92)	12.5 (0.49)	255.0 (10.0)	

All dimensions are in millimetres (inches)

MOUNTING THE DRIVE

The unit must be mounted vertically on a solid, flat, vertical surface, or mounted inside a suitable cubicle, depending upon the required level of EMC compliance - refer to Appendix F: "Technical Specifications".

VENTILATION

The drive gives off heat in normal operation and must therefore be mounted to allow the free flow of air through the ventilation slots and heatsink. Maintain minimum clearances for ventilation as given in the tables below to ensure adequate cooling of the drive, and that heat generated by other adjacent equipment is not transmitted to the drive. Be aware that other equipment may have its own clearance requirements. When mounting two or more AC30V units together, these clearances are additive. Ensure that the mounting surface is normally cool.

Minimum Air Clearance (Frames D, E & F)

Cubicle-Mount Product/Application

(Europe: IP2x, USA/Canada: Open Type).

The drive must be mounted in a suitable cubicle.

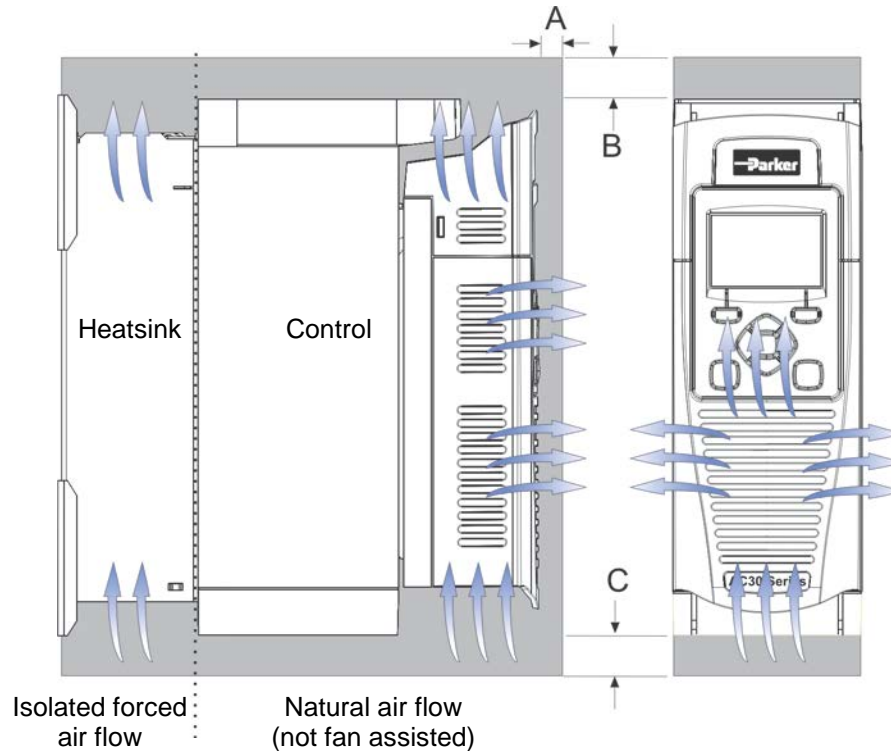

Clearances for IP20 Product (mm)		
A	B	C
10	75	75 minimum (cable entry)

Figure 4-2 Air Clearance for a Cubicle Mount Product/Application, Frame D Illustrated.

4-3 Installation

CUBICLE MOUNTING DETAILS (ALL FRAME SIZES)

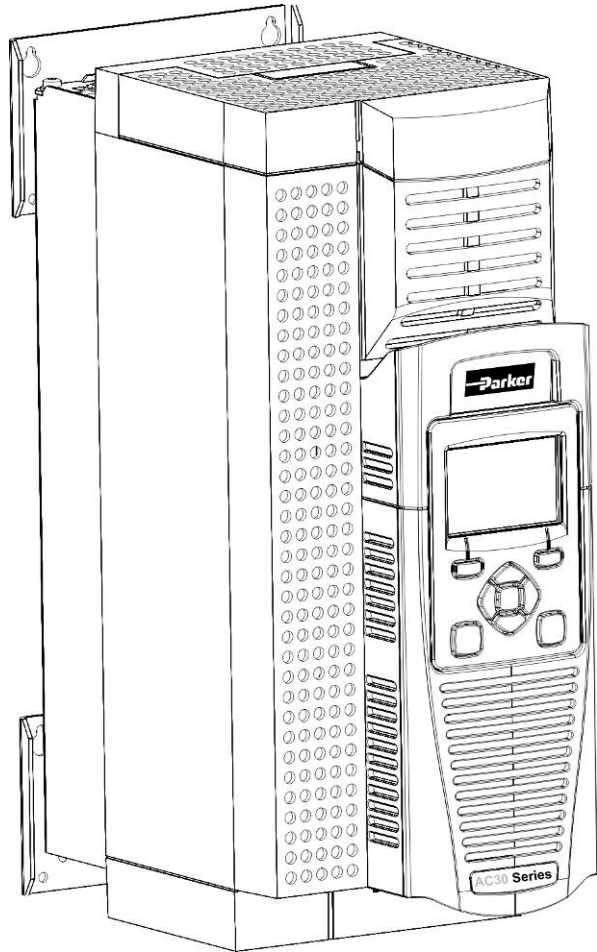

Rear view showing fixing holes for cubicle mount

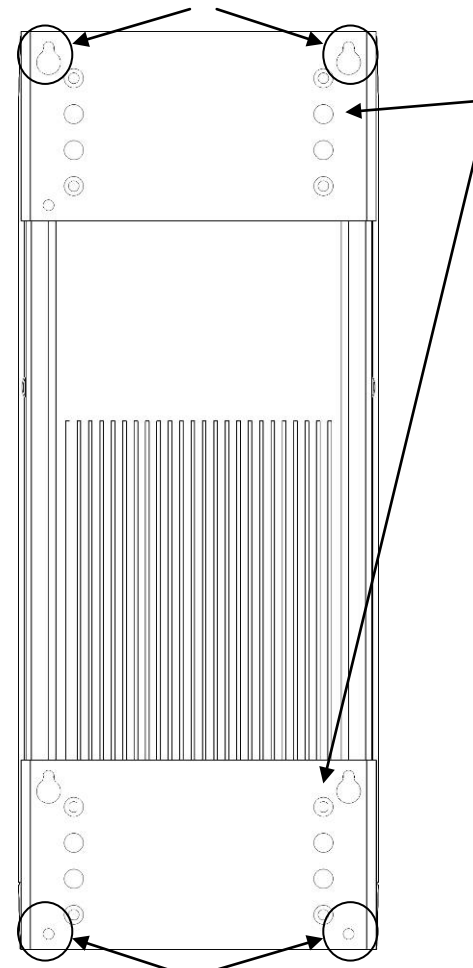

Fixing holes

MOUNTING BRACKETS

The brackets can be moved up/down by using the alternative holes, which are set at 15mm intervals.

For hole and fixing dimensions see page 4-1.

For top and bottom cover removal see page 4-7.

Through Panel Mount

DIMENSIONS FOR THROUGH PANEL INSTALLATION

Through panel mounting a drive in a cubicle allows you to use a smaller cubicle because much of the heat generated by the drive is dissipated outside the cubicle.

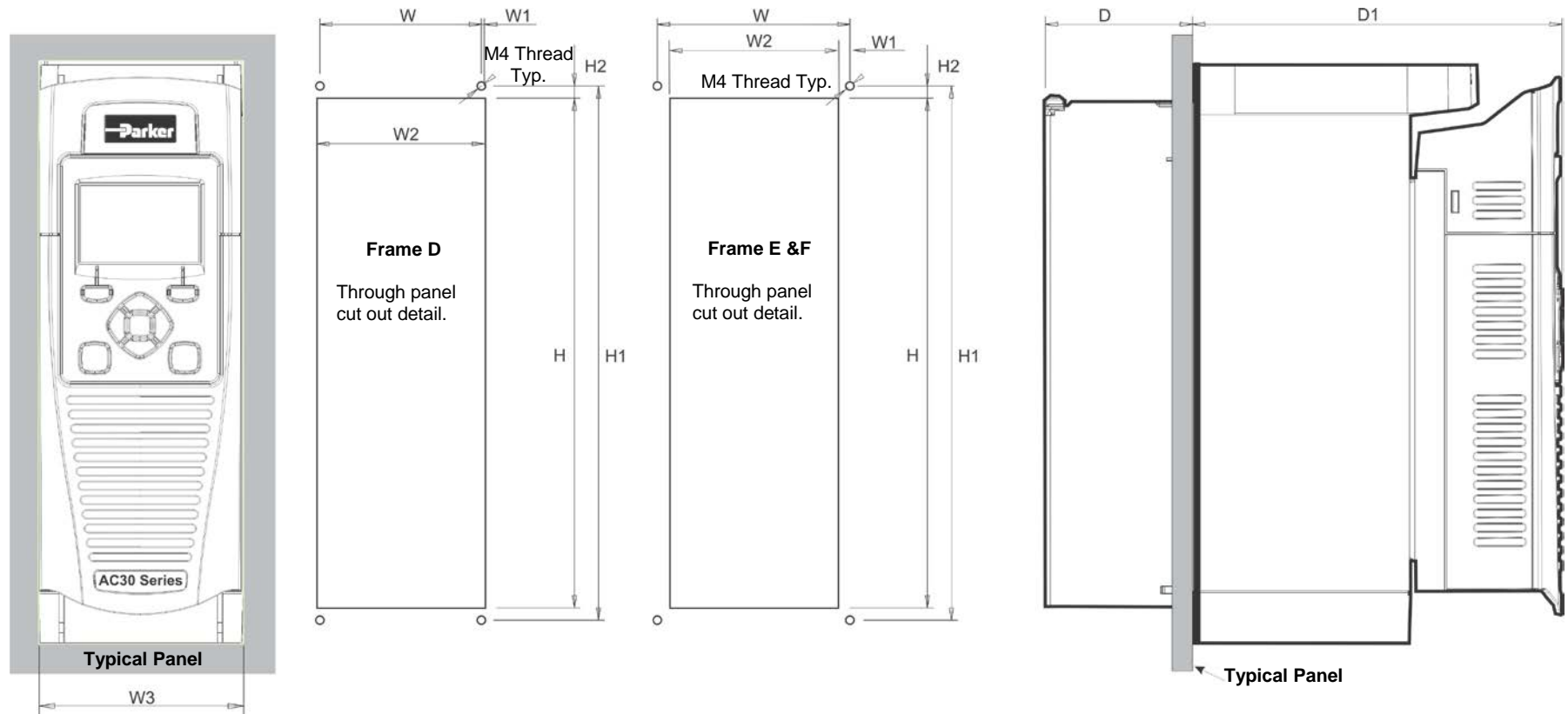

Figure 4-3 Mechanical Dimensions for Through Panel AC30V Drive

Models	H	H1	H2	W	W1	W2	W3	D	D1	Fixings
Frame D	250 (9.8)	262 (10.3)	6 (0.2)	79 (3.1)	1.5 (0.06)	82 (3.2)	100 (3.93)	72 (2.8)	181 (7.1)	Use M4 fixings
Frame E	297 (11.7)	309 (12.1)	6 (0.2)	104 (4.1)	1 (0.04)	102 (4)	125 (4.9)	72 (2.8)	181 (7.1)	
Frame F	347 (13.7)	359 (14.1)	6 (0.2)	129 (5.07)	1 (0.04)	127 (5)	150 (5.9)	72 (2.8)	181 (7.1)	

All dimensions are in millimetres (inches)

4-5 Installation

MOUNTING THE DRIVE

The unit must be mounted vertically on a solid, flat, vertical surface, or mounted inside a suitable cubicle, depending upon the required level of EMC compliance - refer to Appendix F: "Technical Specifications".

VENTILATION

The drive gives off heat in normal operation and must therefore be mounted to allow the free flow of air through the ventilation slots and heatsink. Maintain minimum clearances for ventilation as given in the tables below to ensure adequate cooling of the drive, and that heat generated by other adjacent equipment is not transmitted to the drive. Be aware that other equipment may have its own clearance requirements. When mounting two or more AC30V units together, these clearances are additive. Ensure that the mounting surface is normally cool.

Through-Panel Mount Product/Application (Frames D, E & F)

(Europe: IP2x, USA/Canada: Open Type).

The drive can be mounted in a suitable cubicle.

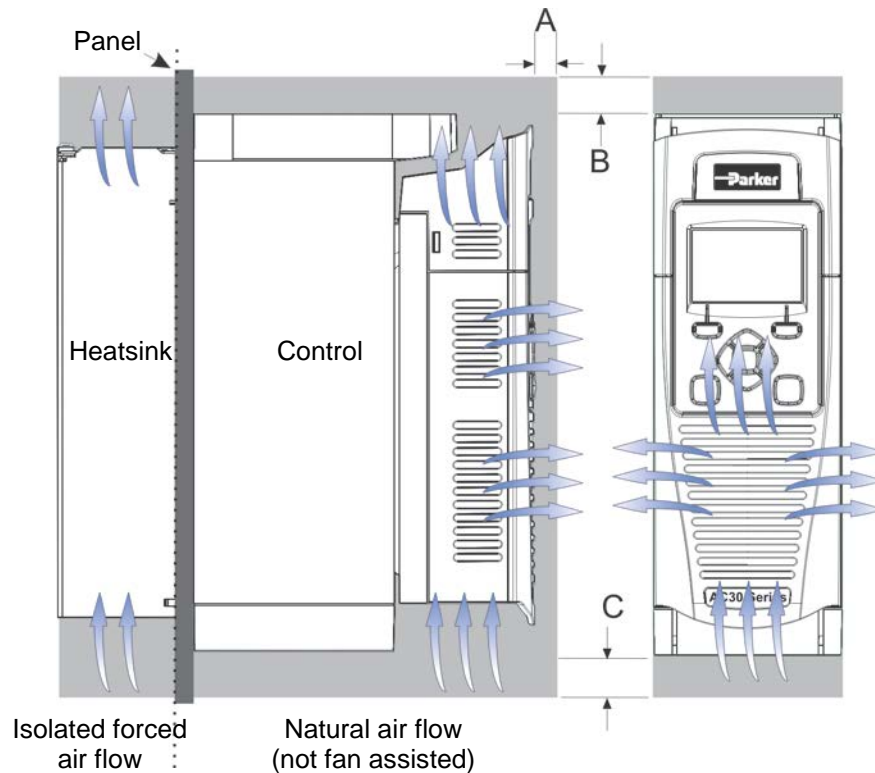

Clearances for Through-Panel Mount IP20 Product (mm)		
A	B	C
10	75	75 minimum (cable entry)

Figure 4-4 Air Clearance for a Through-Panel Mount Product/Application, Frame D Illustrated.

THROUGH PANEL MOUNTING DETAILS (ALL FRAME SIZES)

To allow mounting; first disassemble the drive by following instructions 1 to 4 and then instructions 5 to 7 for mounting:-

1. Unscrew and remove mounting brackets.

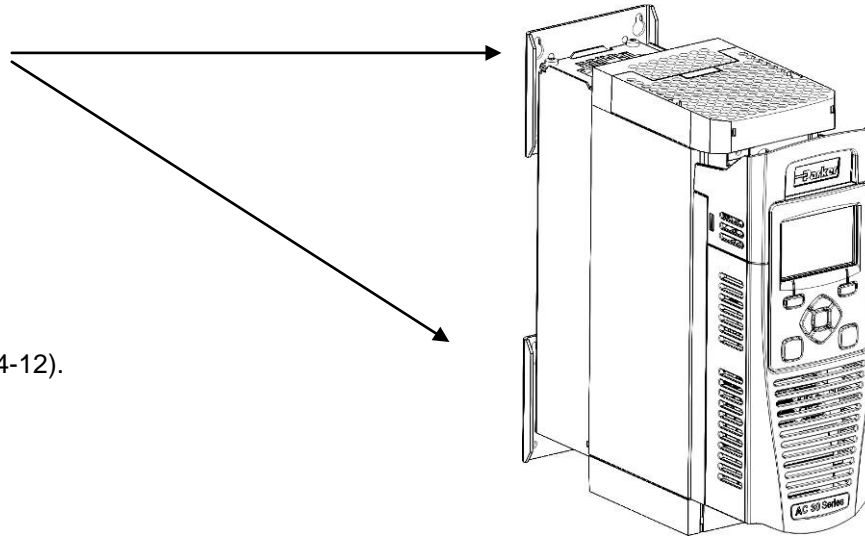

2. Remove Control Module Cover (see page 4-12).

3. Remove Control Module (see page 4-13)

4. *Top & Bottom Cover Removal Instructions*

Frame D only

Top Cover: Squeeze together the bracket under the top cover and lift off cover.

Bottom Cover: After inserting a screwdriver into the slot **slightly push to the left** to release the catch.

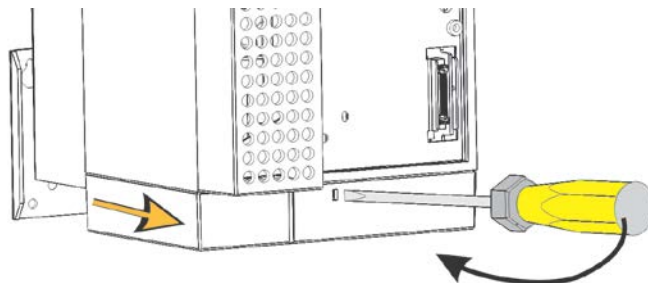
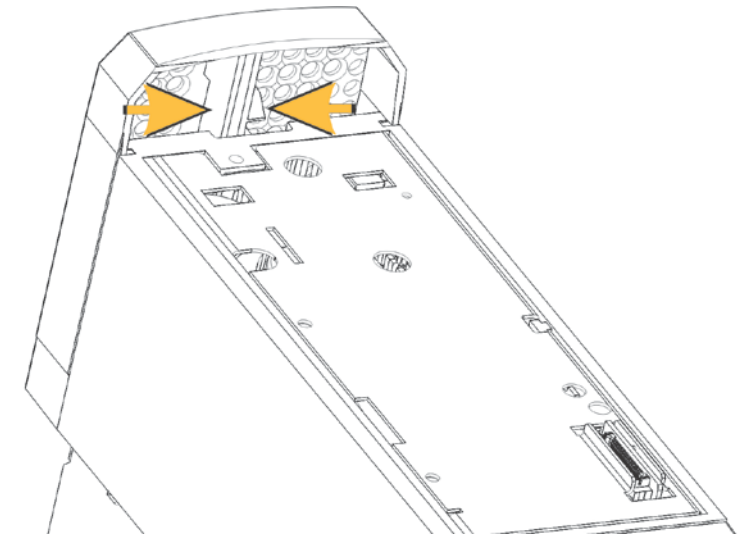

4-7 Installation

Frames E & F

Top Cover:

To remove insert a screwdriver into the slot and **move to the right** to release the catch, and then **slide off** cover.

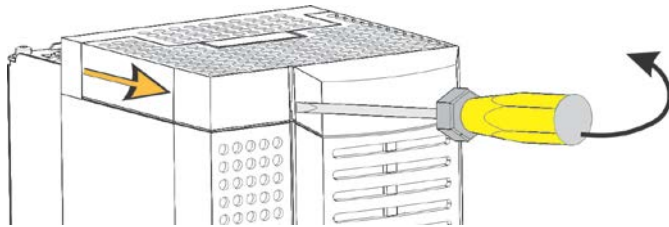

Bottom Cover:

To remove bottom cover insert a screwdriver into the slot and **move to the left** to release the catch, and then **slide off** cover.

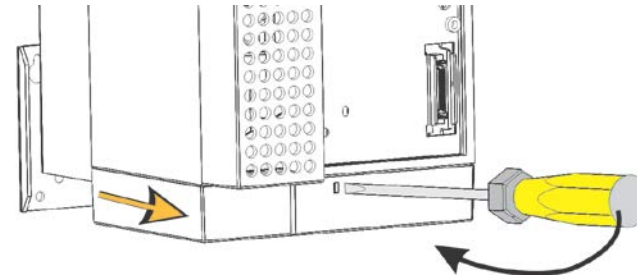

Installation 4-8

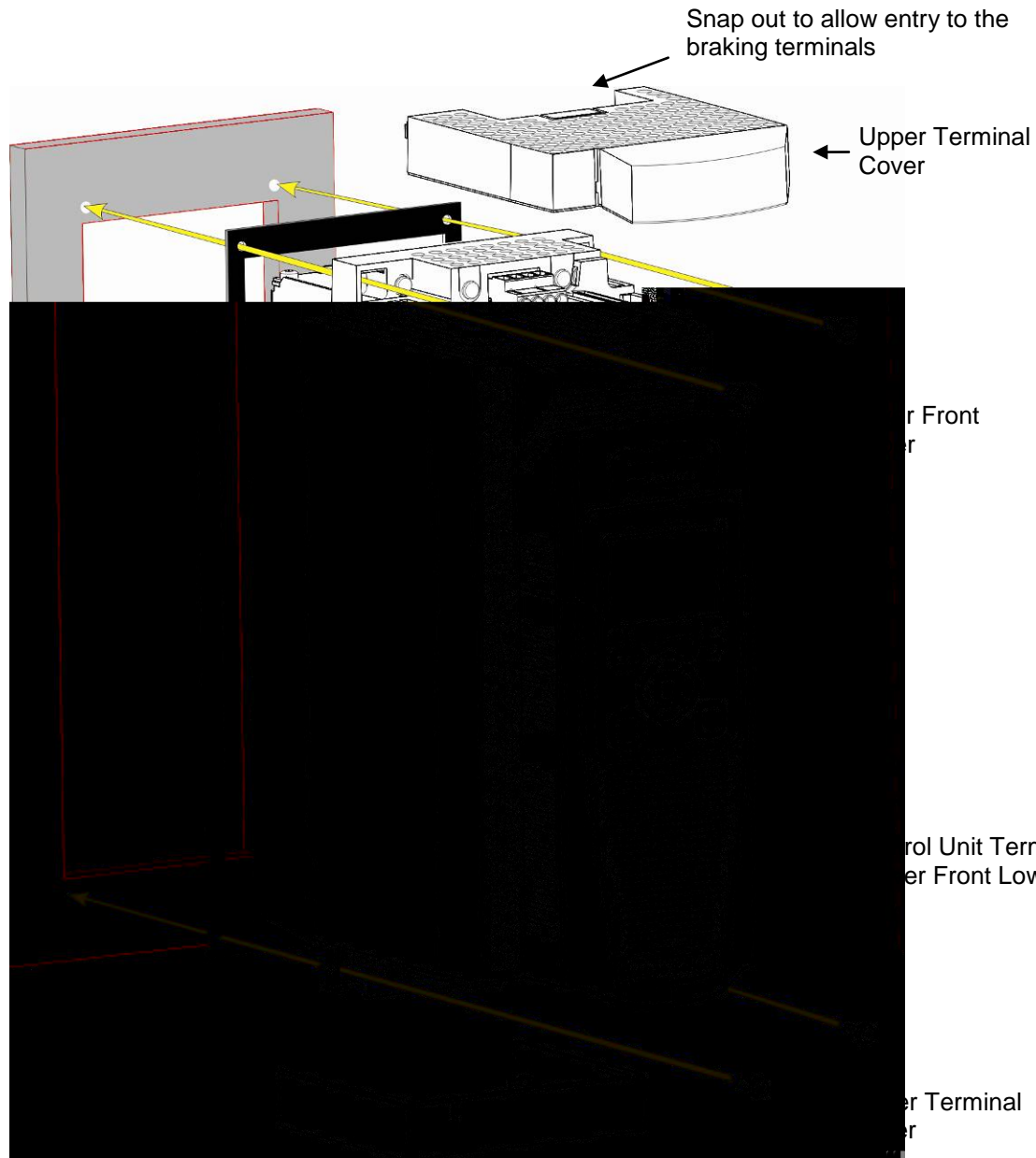

5. Fit gasket to the drive so that an air-tight seal will be made between the drive and the panel.

Gaskets can be purchased from Parker using the following part numbers:

Frame D – BO501911U001
Frame E – BO501911U002
Frame F – BO501911U003

6. Tighten top and bottom screws in place as shown to 1.3Nm.
7. At this stage you can wire the power cables, see page 4-11

4-9 Installation

Cabling Bracket for Control & Main Cable

With the bottom cover off you can screw the cabling brackets in place, if required.

The cabling brackets are standard with C2 filtering products and can be obtained from Parker using the following part numbers:

The part numbers for the cabling brackets are:

Frame D – LA501935U001

Frame E – LA501935U002

Frame F – LA501935U003

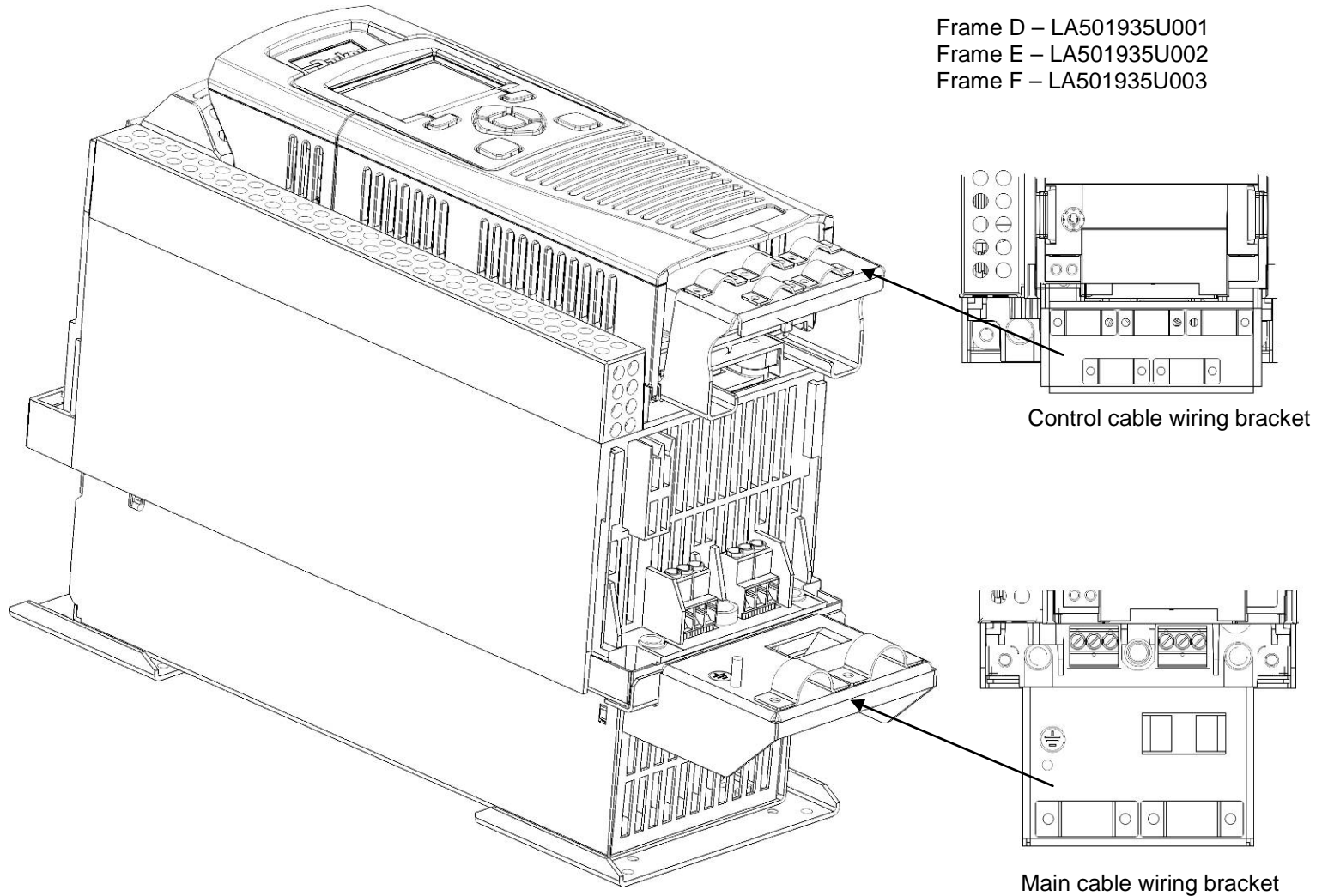

Control cable wiring bracket

Main cable wiring bracket

Electrical Installation

IMPORTANT Please read the Safety Information in “Chapter :1 Safety” before proceeding.

Also refer to Appendix C: Compliance

WIRING INSTRUCTIONS

IMPORTANT: *The control board 0V must be connected to protective earth outside of the product to meet EMC and safety requirements.*

Note: You can still operate the drive in Local mode, if necessary, with any Application selected.

Power Wiring Connections

Protective Earth (PE) Connections



The unit must be **permanently earthed** according to EN 61800-5-1 - see below. Protect the incoming mains supply using a suitable fuse or circuit breaker (circuit breaker types RCD, ELCB, GFCI are not recommended).

IMPORTANT: *The drive is only suitable for earth referenced supplies (TN) when fitted with an internal filter. External filters are available for use on TN and IT (non-earth referenced) supplies.*

For installations to EN 61800-5-1 in Europe:

- For permanent earthing, two individual incoming protective earth conductors (<math><10\text{mm}^2</math> cross-section) or one conductor (>math>>10\text{mm}^2</math> cross-section) are required. Each earth conductor must be suitable for the fault current according to EN 60204.

Refer to Appendix C: “Compliance” - EMC Installation Options.

4-11 Installation

POWER WIRING CONNECTIONS

Feed the power supply and motor cables into the drive under the cable clamps using the correct cable entries, and connect to the power terminals. Tighten all terminals to the correct tightening torque; refer to the Terminal Tightening Torques table (page 4-26).

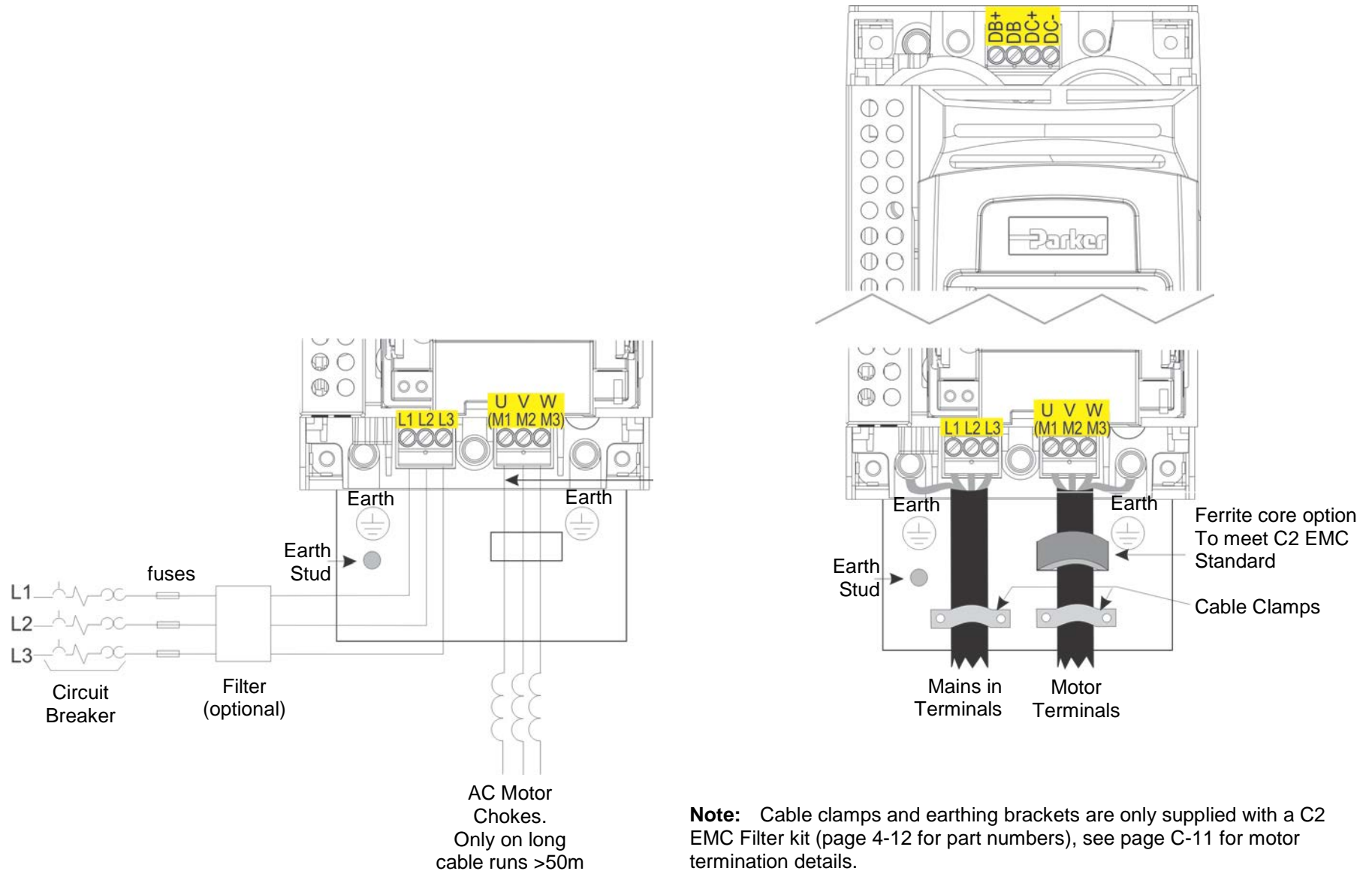

Control Module Cover Removal

To gain access to the control wiring first remove the control module cover as follows:

1. First remove the GKP by pulling from the top down, and remove.

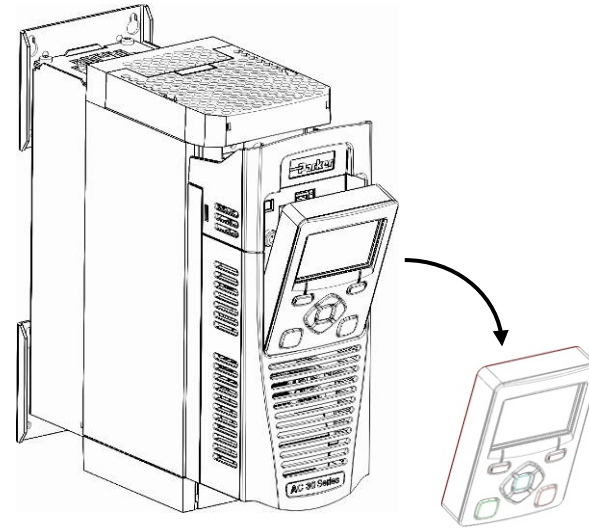

2. Undo the screw and slide the control module cover down slightly, then remove.

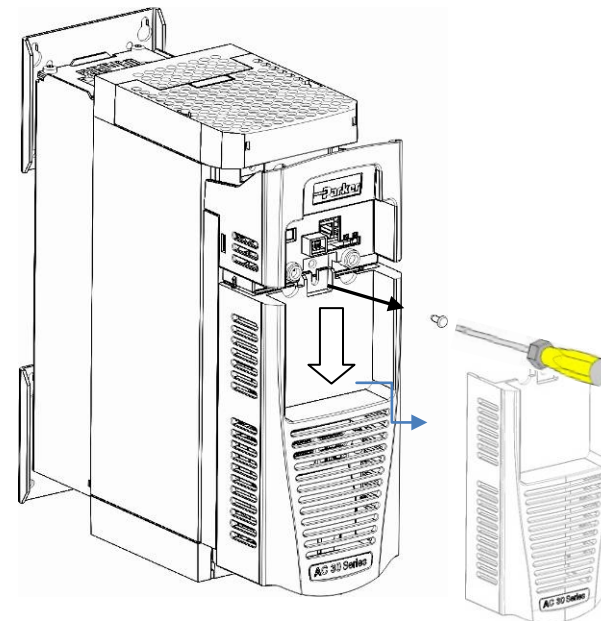

4-13 Installation

Control Module Removal

WARNING Isolate supply before plugging or unplugging control unit to the power stack.

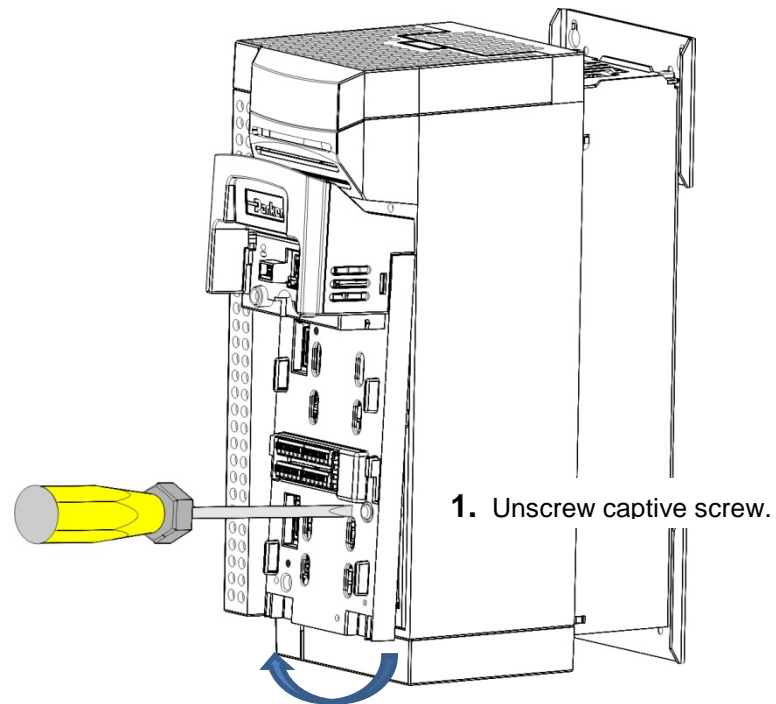

2. Lift lower edge of assembly.

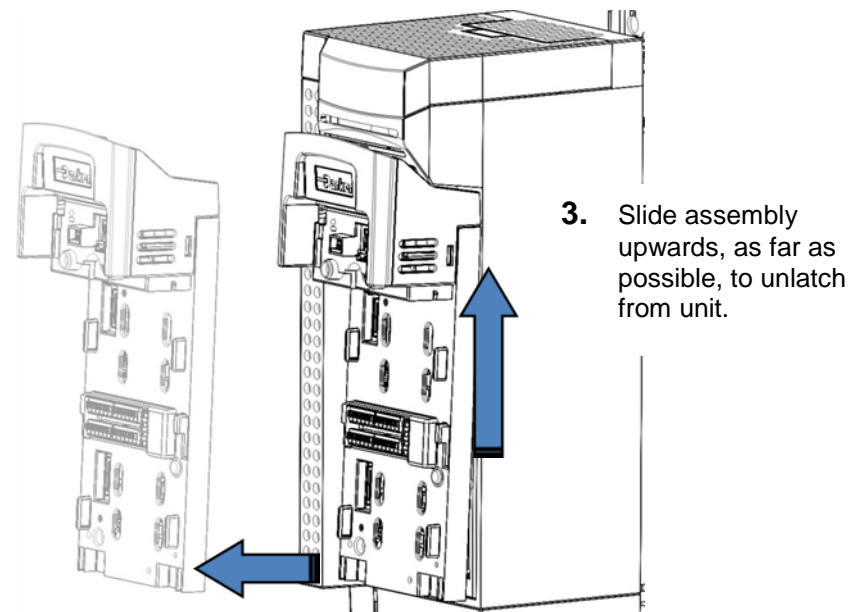

4. Lift assembly away from Power Stack

CONTROL WIRING CONNECTIONS

Terminal ID	Function
X10/01	STO A Input
X10/02	STO Common
X10/03	STO B Input
X10/04	STO Common
X10/05	STO Status A
X10/06	STO Status B
X11/01	ANIN 01 (+10V, 0-10V, 0-20mA, 4-20mA)
X11/02	ANIN 02 (+10V, 0-10V)
X11/03	ANOUT 01 (+10V, 0-10V)
X11/04	ANOUT 02 (0-10V, 0-20mA, 4-20mA)
X11/05	+10V reference
X11/06	-10V reference
X12/01 (LH)	DIGIN 04 / DIGOUT 01
X12/02	DIGIN 05 / DIGOUT 02
X12/03	DIGIN 06 / DIGOUT 03
X12/04	DIGIN 07 / DIGOUT 04
X12/05	User +24V output
X12/06	0V

Terminal ID	Function
X13/01 (LH)	0V
X13/02	DIGIN 1
X13/03	DIGIN 2
X13/04	DIGIN 3
X13/05	+24V AUX input
X13/06	0V AUX input
X14/01 (BOT)	Relay 01 (contact A)
X14/02	Relay 01 (contact B)
X14/03	Relay 02 (contact A)
X14/04	Relay 02 (contact B)

Control Wiring Layout Diagram

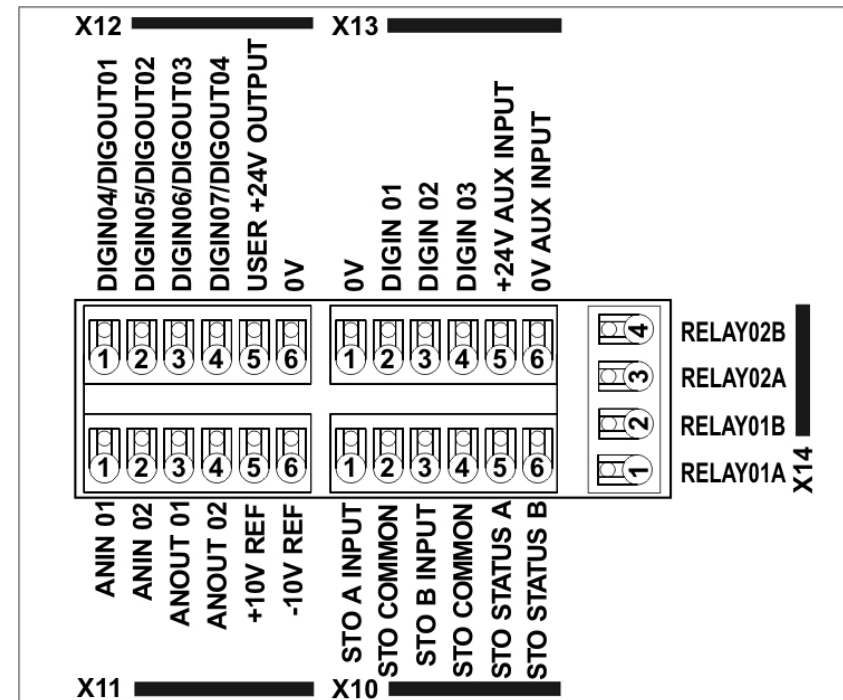

4-15 Installation

Wiring Diagrams

APPLICATION 0: BASIC SPEED CONTROL

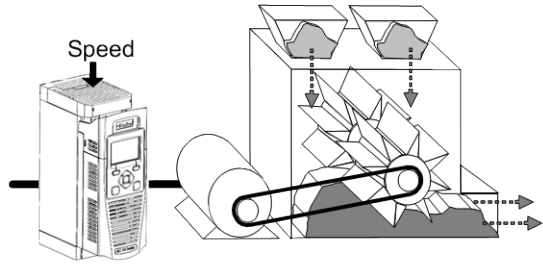

Application 0:
 "Basic Speed Control"
 IDEAL FOR GENERAL PURPOSE APPLICATIONS,
 NORMAL DUTY AND HEAVY DUTY

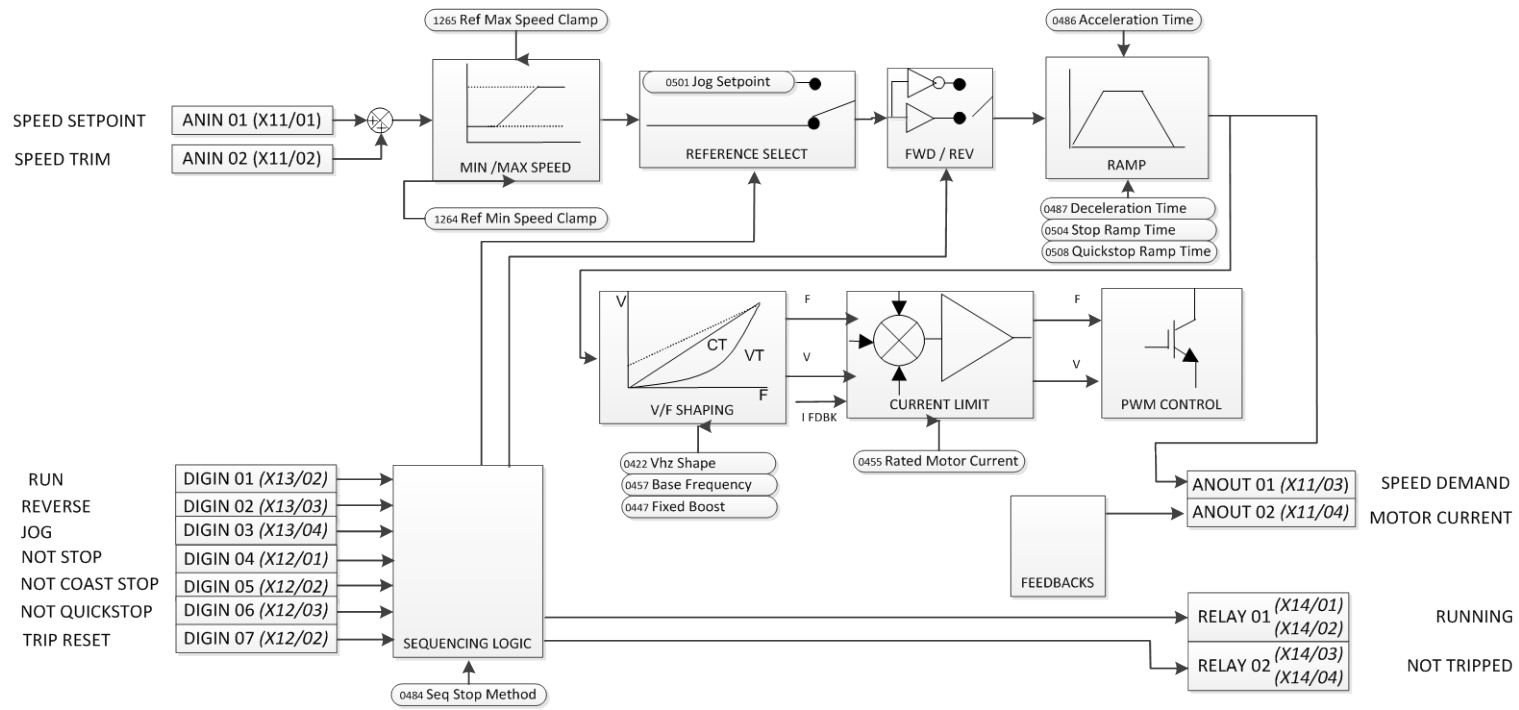

Basic Speed Control Wiring

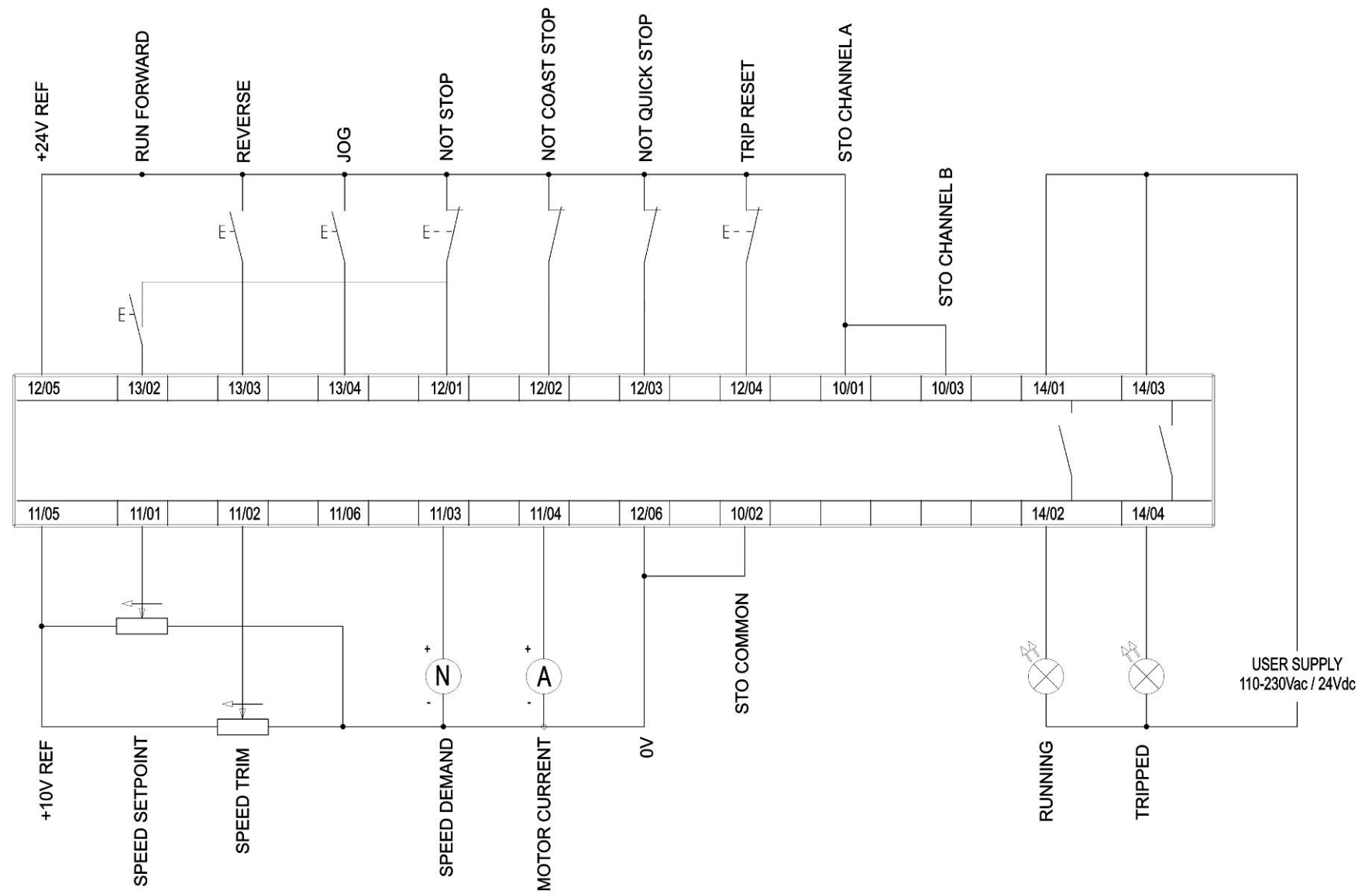

4-17 Installation

APPLICATION 1: AUTO/MANUAL CONTROL

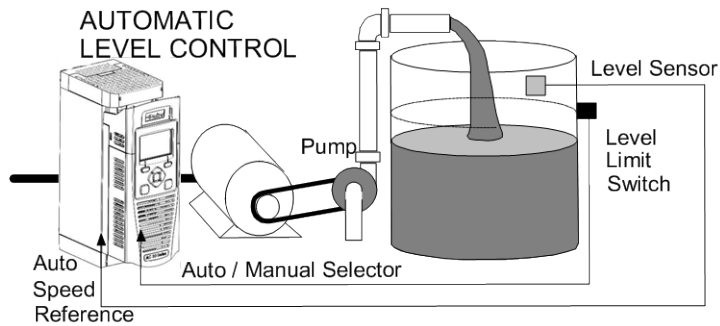

Application 1:
“Auto/Manual Control”
 IDEAL FOR AUTOMATIC CONTROL
 APPLICATIONS WITH LIMIT SWITCHES OR
 PROXIMITY TRANSDUCERS

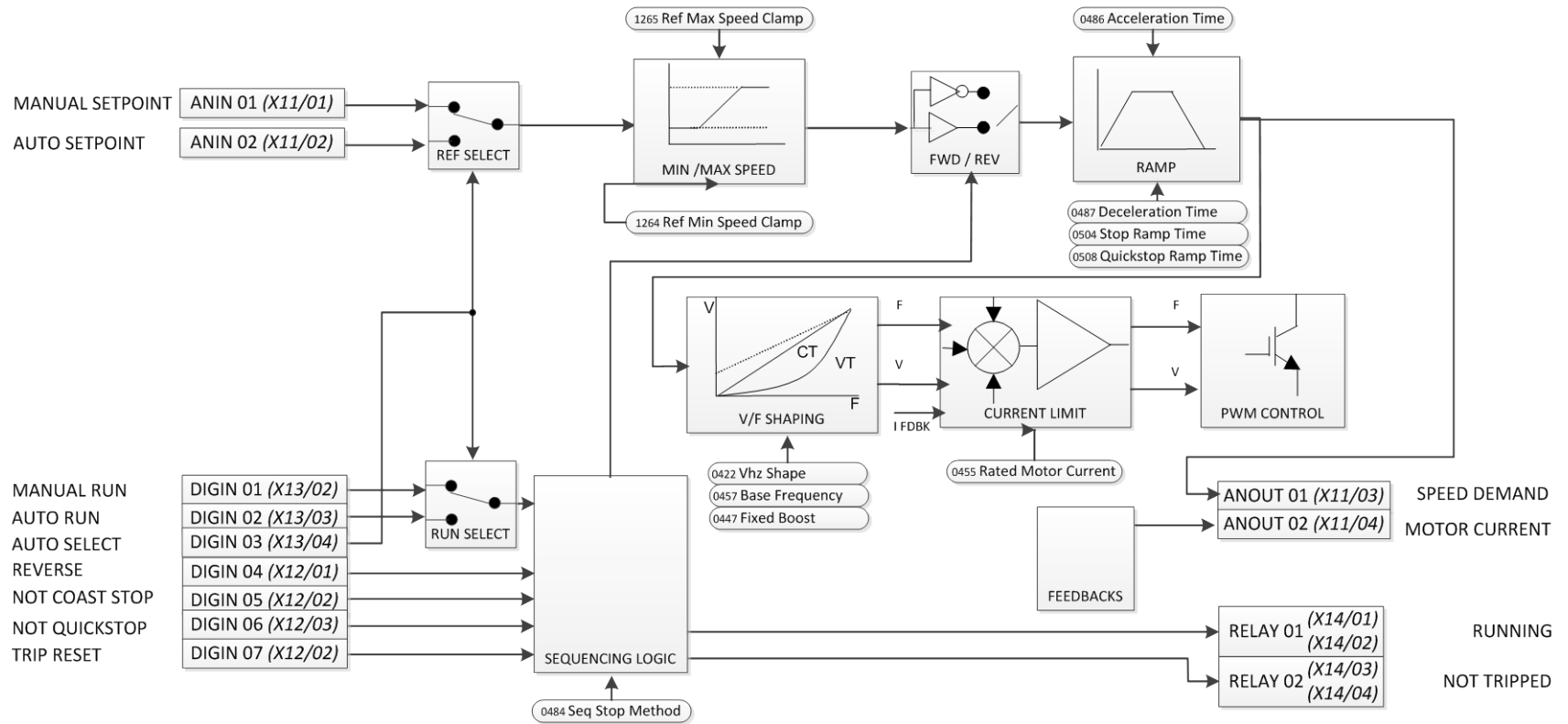

Auto/Manual Control Wiring

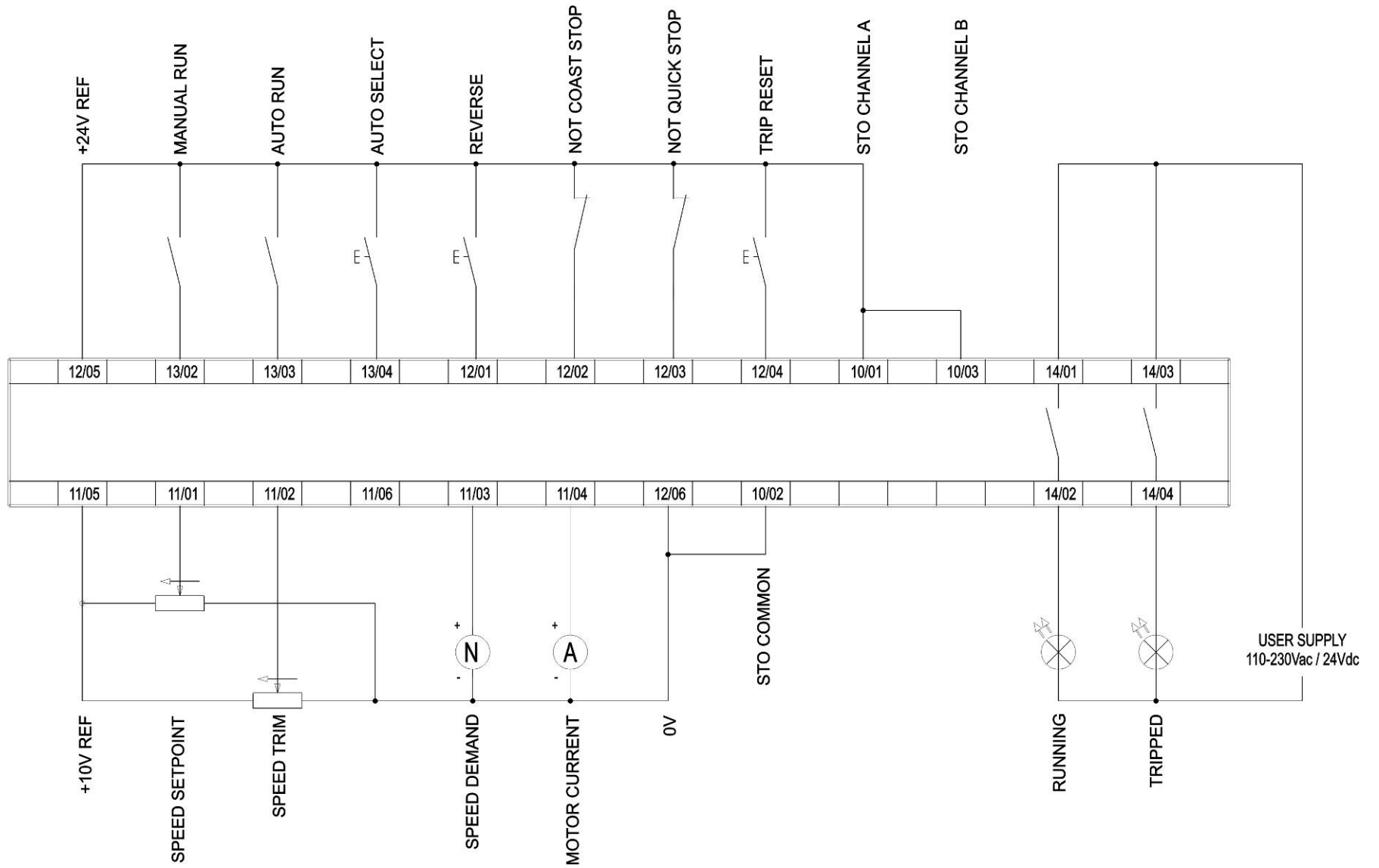

4-19 Installation

APPLICATION 2: RAISE / LOWER TRIM

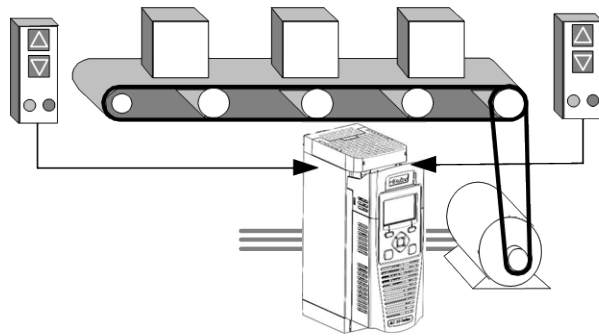

Application 2:
“Speed Raise/Lower”
 IDEAL FOR APPLICATIONS REQUIRING SPEED CONTROL FROM MULTIPLE LOCATIONS

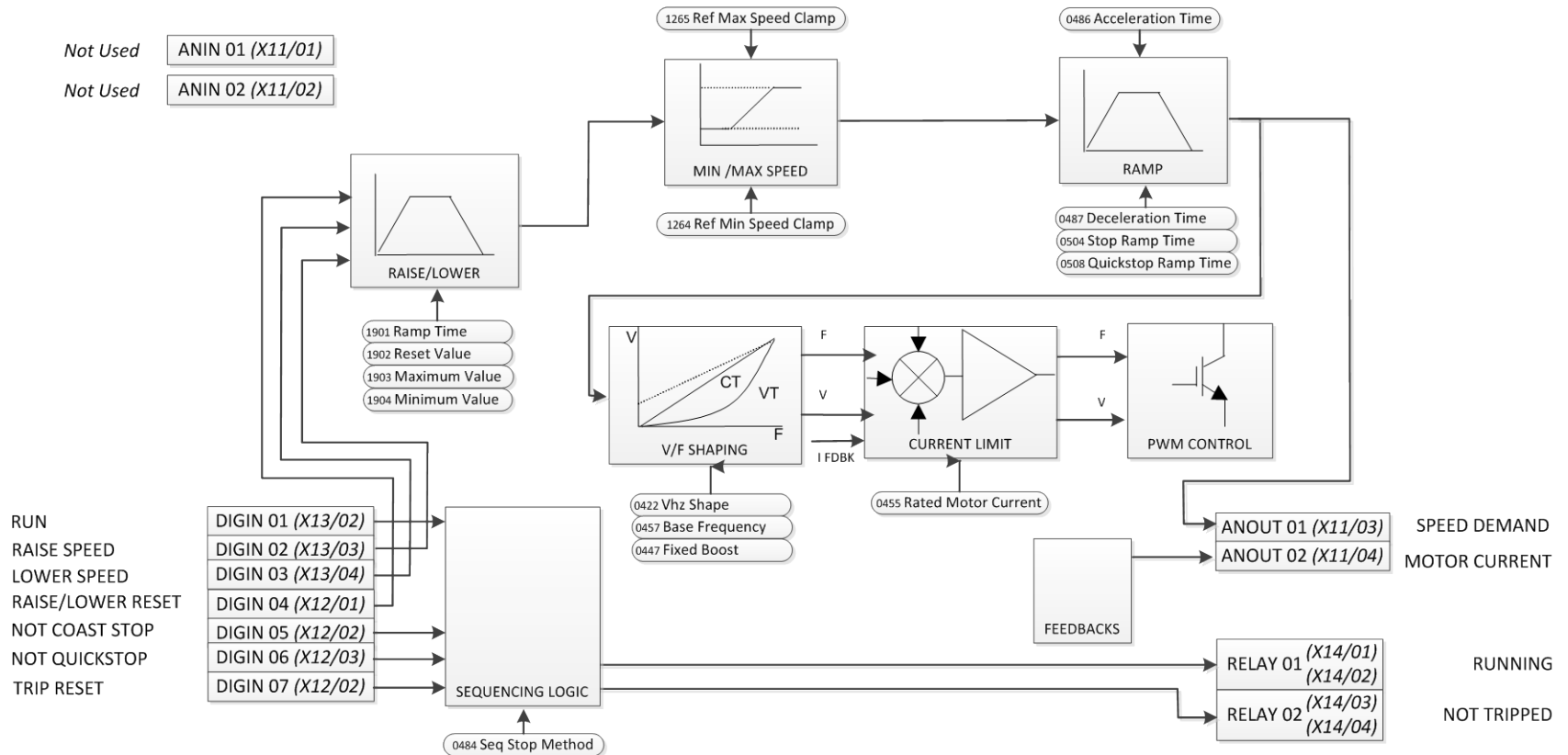

Raise/Lower Trim Wiring

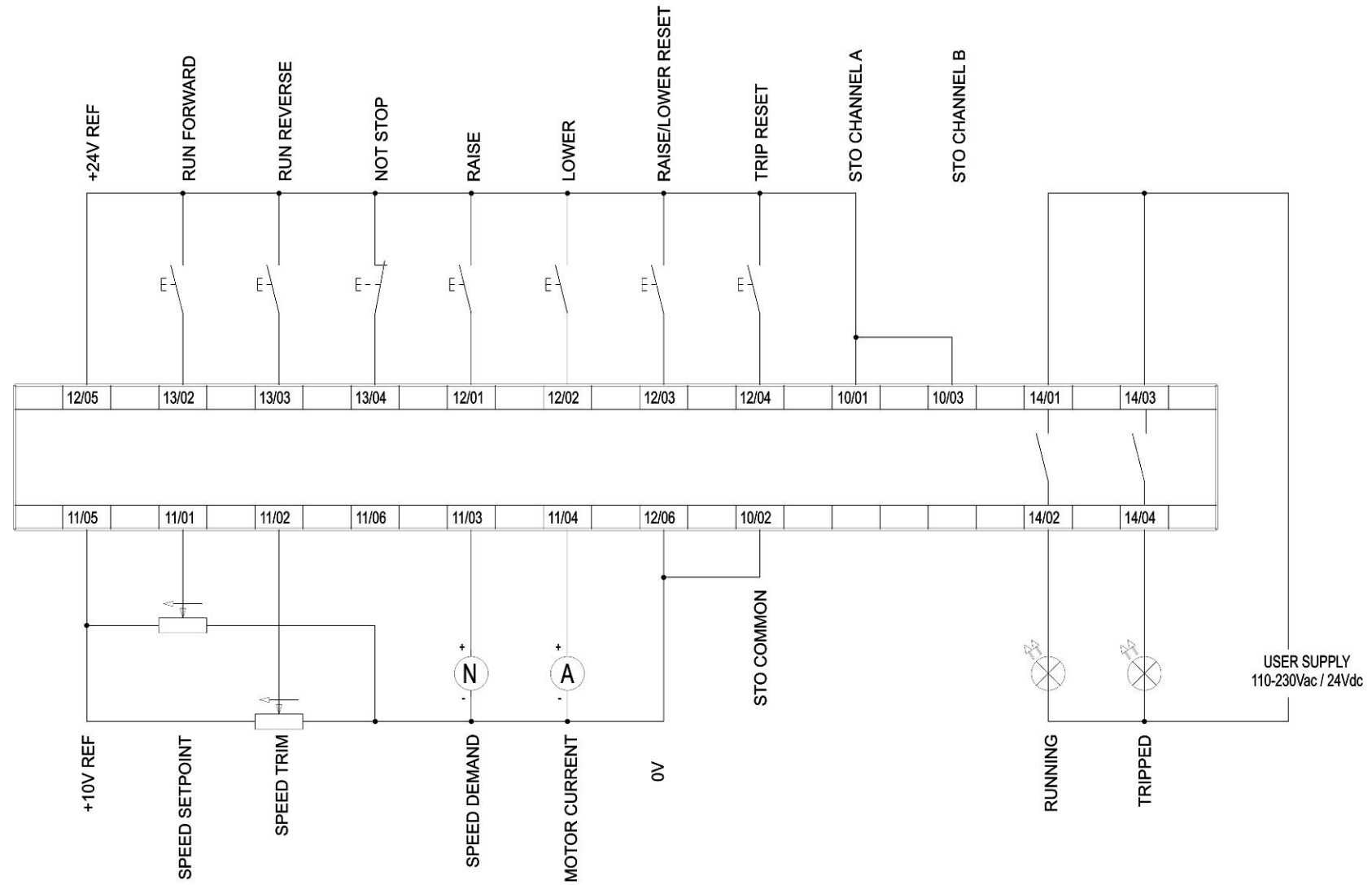

4-21 Installation

APPLICATION 3: PRESETS SPEEDS

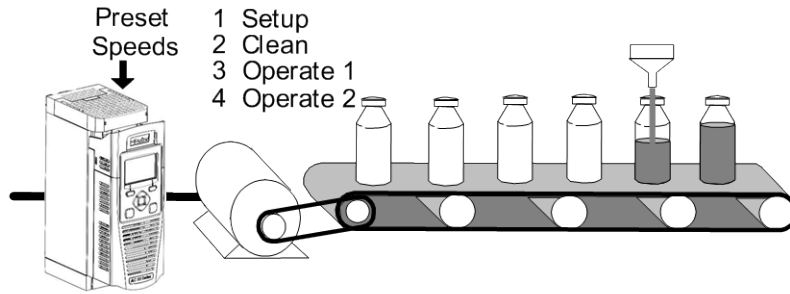

Application 3:
 "Speed Presets"
 IDEAL FOR GENERAL PURPOSE APPLICATIONS
 REQUIRING MULTIPLE DISCRETE SPEED LEVELS

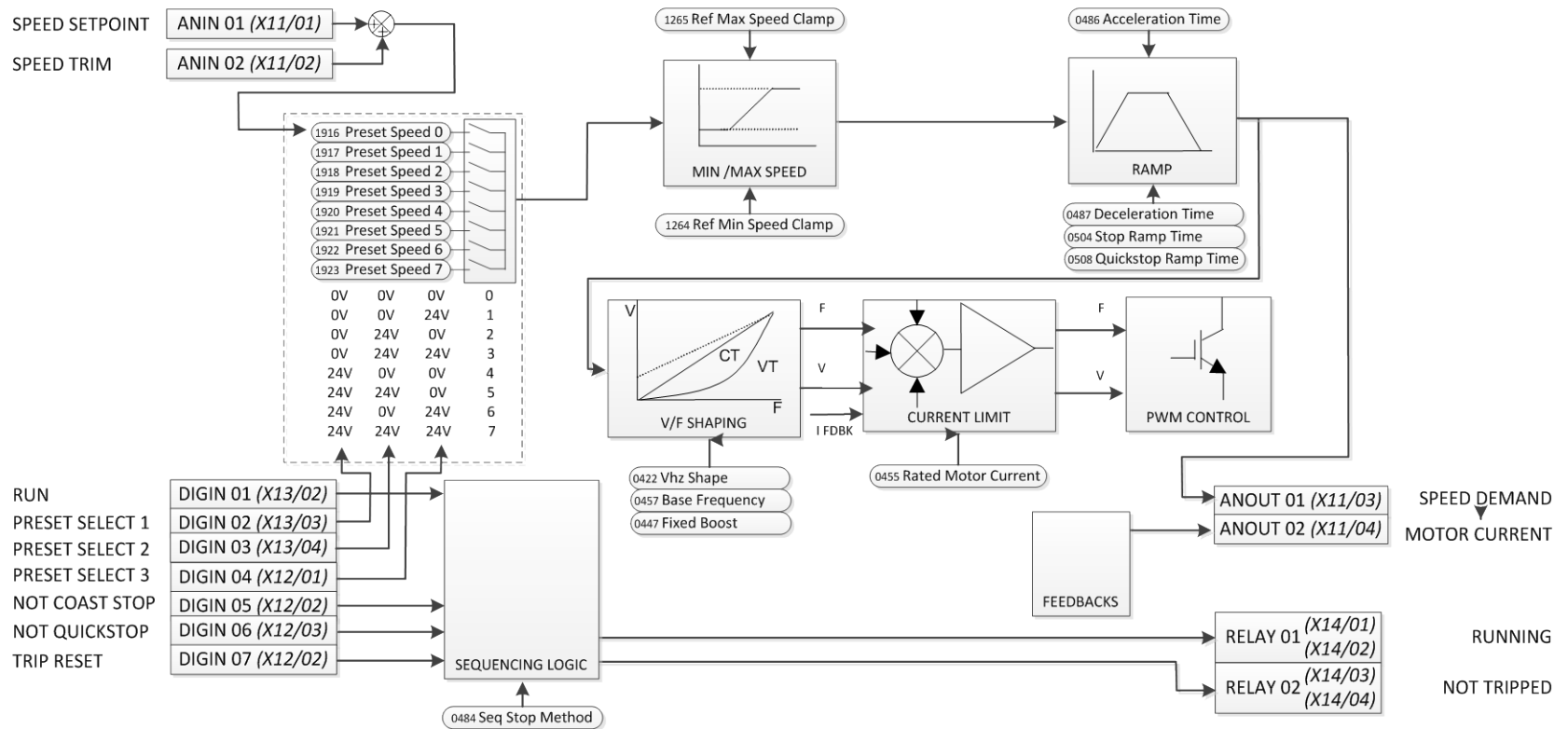

Presets Speeds Wiring

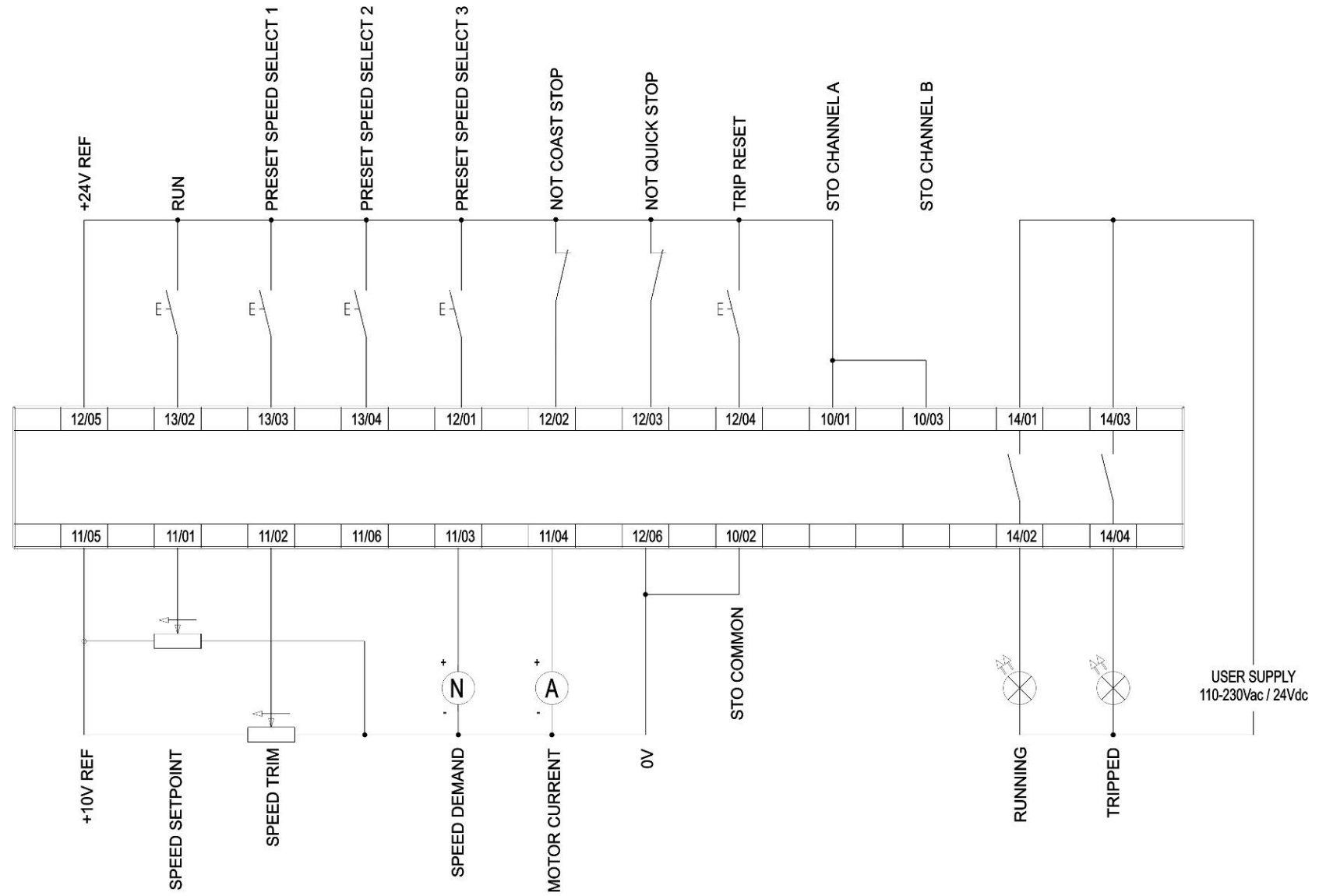

4-23 Installation

APPLICATION 4: PID CONTROL

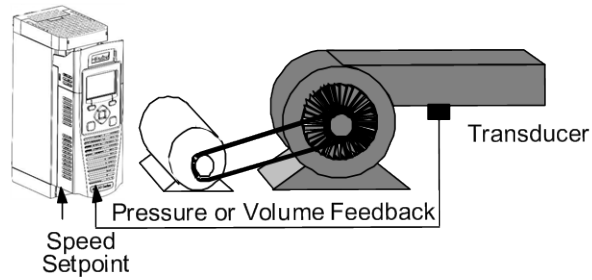

Application 4: "Process PID"

EASY TUNING FOR SETPOINT/FEEDBACK CONTROL APPLICATIONS REGULATING VOLUME OR PRESSURE, SUCH AS AIR HANDLING OR PUMPING

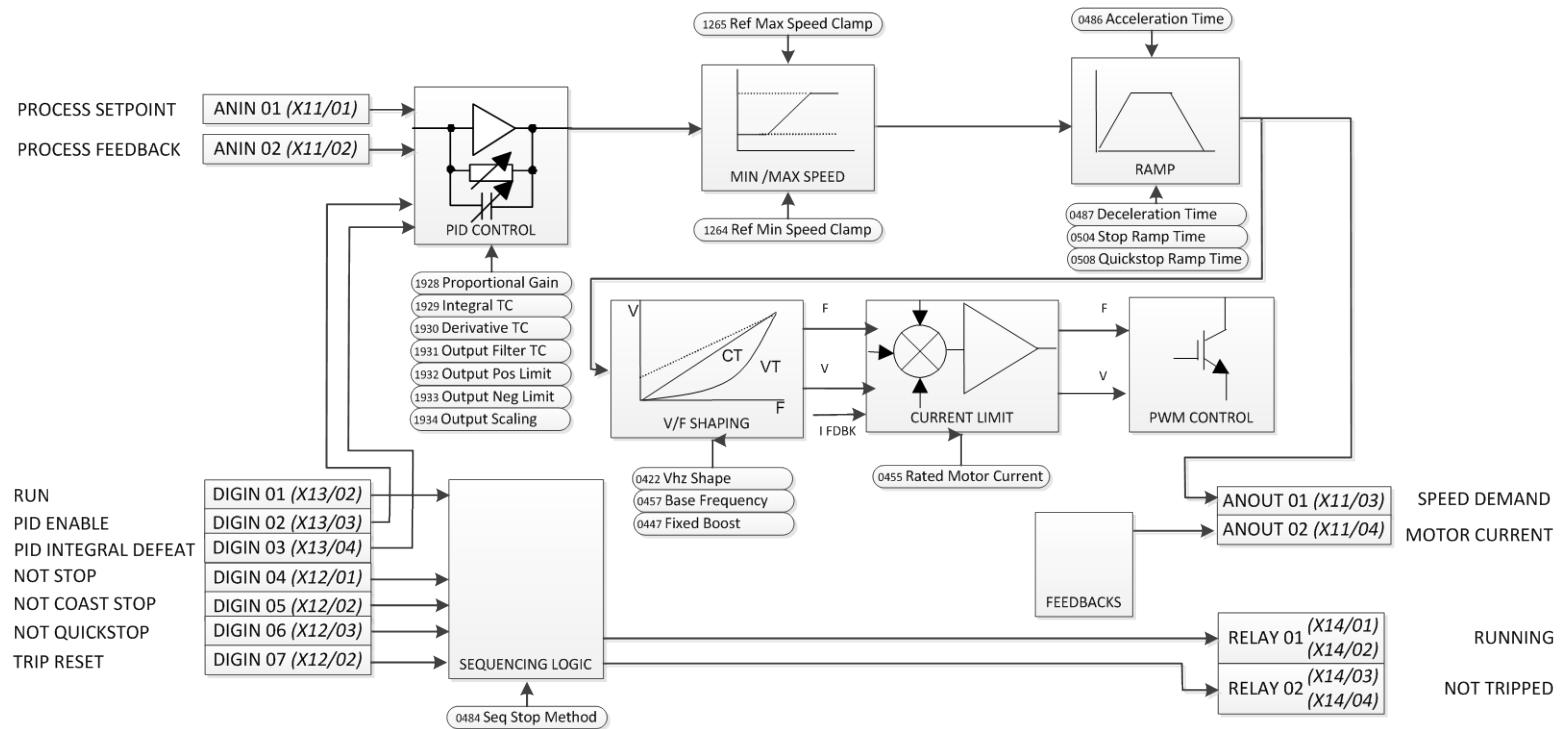

PID Control Wiring

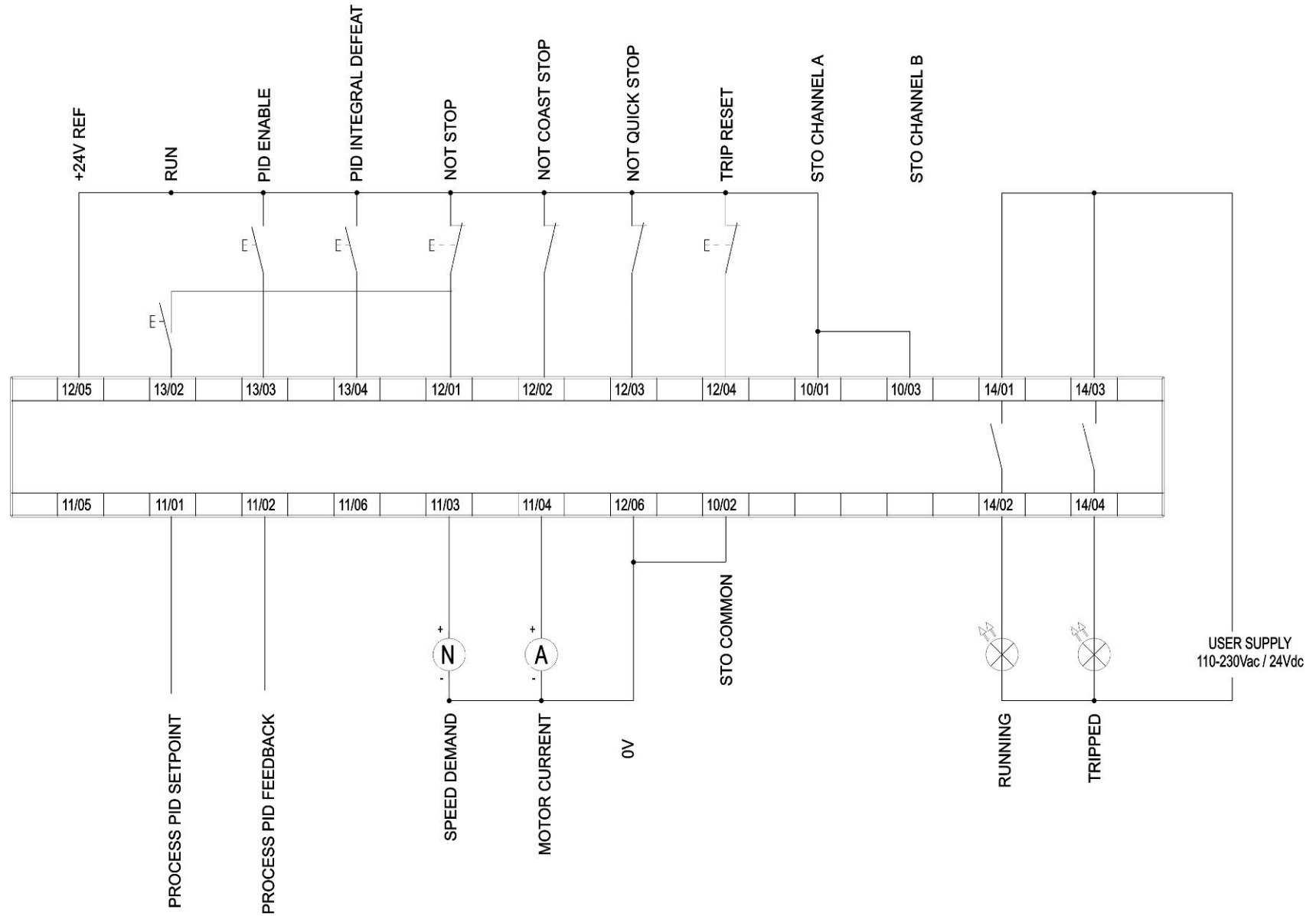

4-25 Installation

TERMINAL BLOCK WIRE RANGE

Wire sizes for Europe should be chosen with respect to the operating conditions and your local National Electrical Safety Installation Requirements. Local wiring regulations always take precedence. For North American UL wire sizes refer to Appendix C: "Compliance" - Requirements for UL Compliance.

Product Code	Power Terminals (minimum/maximum acceptance for aperture)	Control Terminals
31V-4D0004- ... 31V-4D0005- ... 31V-4D0006- ... 31V-4D0008- ... 31V-4D0010- ... 31V-4D0012- ...	0.05 - 6 mm ²	0.229 - 2.5 mm ²
31V-4E0016- ... 31V-4E0023- ...	0.05 – 6 mm ²	0.229 - 2.5 mm ²
31V-4F0032- ... 31V-4F0038- ...	1 - 10 mm ² (*16 mm ²)	0.229 – 2.5 mm ²
*The larger wire size can be used provided a crimp is fitted to the wire		

Note: Earth connections are for M4 ring crimps.

TERMINAL TIGHTENING TORQUES

Frame Size	Power Terminals	DC Bus Terminals	Brake Terminals	Ground Stud
Frame D	0.56-0.8Nm (5-7 lb-in)	0.56-0.8Nm (5-7 lb-in)	0.56-0.8Nm (5-7 lb-in)	1.8Nm (16 lb-in)
Frame E	0.56-0.8Nm (5-7 lb-in)	0.56-0.8Nm (5-7 lb-in)	0.56-0.8Nm (5-7 lb-in)	1.8Nm (16 lb-in)
Frame F	1.35Nm (12 lb-in)	1.35Nm (12 lb-in)	1.35Nm (12 lb-in)	1.8Nm (16 lb-in)

OPTIONAL EQUIPMENT

Refer to Chapter 5 Associated Equipment.

BRAKE WIRING

Refer to Chapter 5 Associated Equipment on wiring details.

4-27 Installation

Fitting a Remote GKP

When fitting the GKP remotely to either a cubicle or panel mount it **must** be fitted to a flat surface. Maximum cable length < 3 meters.

- If ordered separately the GKP kit comprises; GKP and connecting lead – part number 7001-00-00
- If ordered and supplied with the drive the connection lead is not supplied.

Cut out details:

GKP – Reverse side

The yellow dotted line is the cutout detail to allow remote fitting the connection lead, also shows screw hole details.

Use M3 x 10 self tapping screws.

Connection lead RS232/REM OP STA with a Steward 28A2025-OAO connector.

All measurements in millimeter.

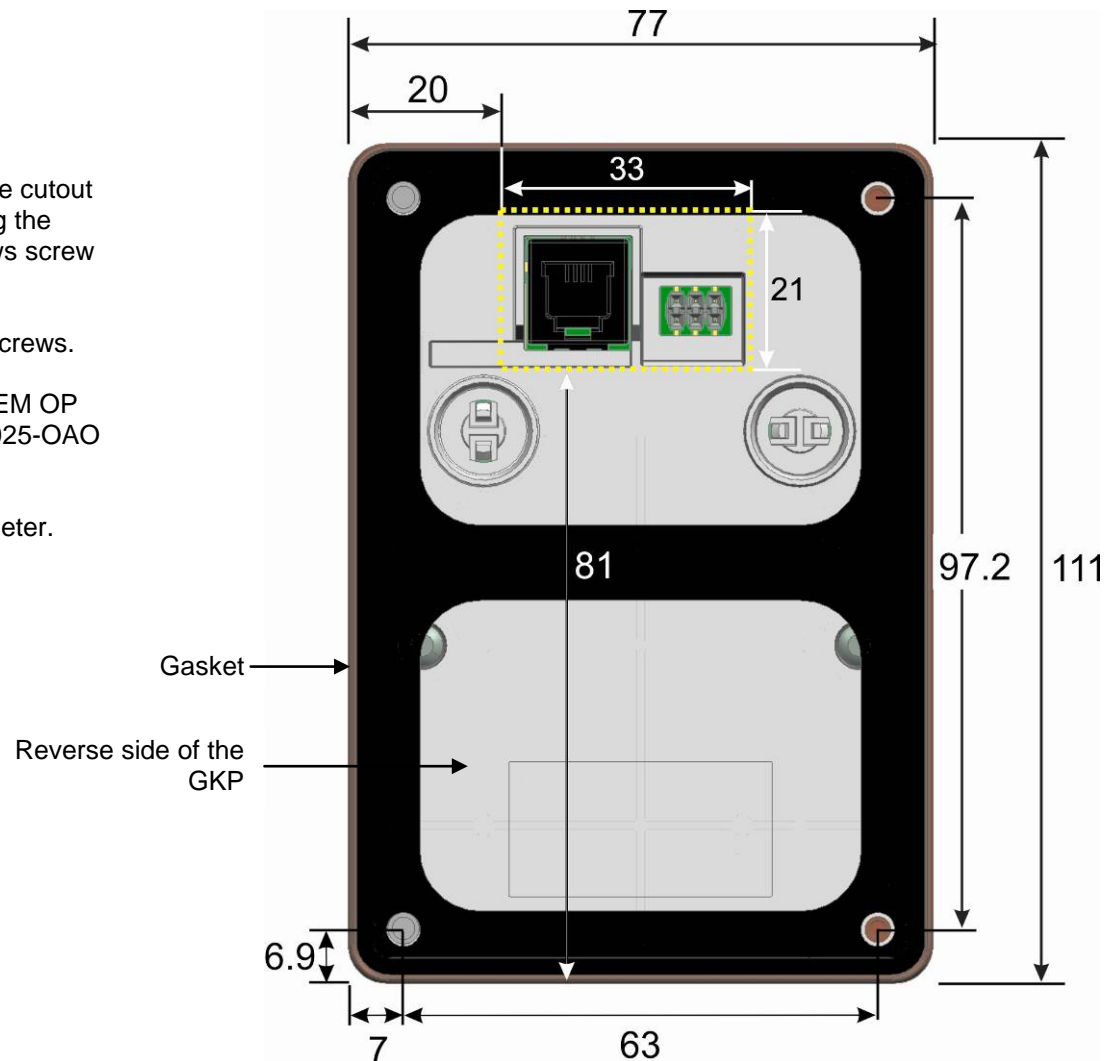

Getting Started

GKP SETUP WIZARD

Purpose of the Setup Wizard

The purpose of the setup wizard is to configure the drive in a clear and concise manner.

First familiarize yourself with Chapter 7 Graphical Keypad, for the keypad functions.

Starting the Setup Wizard

The Setup Wizard is automatically invoked when the drive is reset to factory default settings. The setup wizard may be invoked at any other time by changing the parameter “Run Setup?” to YES (you will find this in the “Setup” menu).

Running the Setup Wizard

At each point in the wizard pressing the OK key selects the displayed value and moves on to the next step. Pressing **Soft Key 1** moves back a step. Pressing the UP and DOWN keys modifies the selected value.

Setup Wizard Stages

The first option presented is “Set Factory Defaults”. Changing this parameter to TRUE then pressing OK resets all parameters back to the default value determined by the AC30V’s hardware configuration. If this choice is left FALSE the setup wizard starts with all parameters with their previously set values. Accepting each choice without change by pressing OK will result in no change to the drive’s configuration.

The next option is to select the Language that is to be used to present information on the GKP and the web page, (when enabled).

The rest of the Setup Wizard consists of a several sections. Each section corresponds to a functional component of the drive, for example:

- Application selection
- Motor Data
- Analog input and output ranges.
- Fieldbus options
- On-board Ethernet
- Auto tune

If not required, any section may be skipped.

The default setting for all parameters depends on earlier answers and on the physical configuration of the drive. All data entered is automatically saved without the need for any additional commands.

Finalising Setup

Once the Setup Wizard has been run to completion the feature is automatically disabled. Re-starting the drive will not cause the Setup Wizard to be run again. (If it is desired to re-run the Setup Wizard, this can be achieved as detailed above in “Starting the Setup Wizard”).

For complete details go to “Chapter 9 Setup Wizards”.

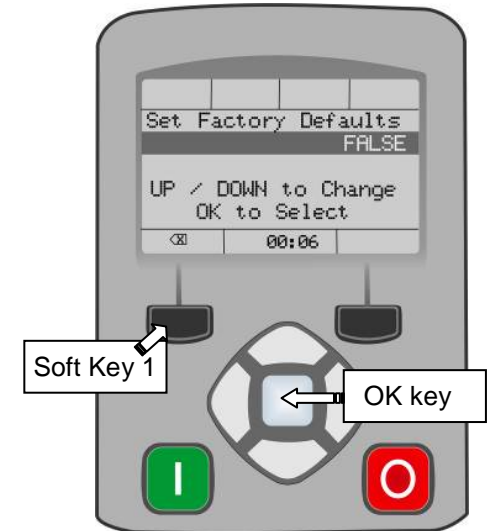

4-29 Installation

ETHERNET COMMUNICATIONS

The AC30V comes with built-in Ethernet providing communications with the PDQ, a Modbus TCP server and a web server.

Connecting the Ethernet Cable

See Chapter 12 Ethernet for full cable information.

Diagram showing how to insert the Ethernet cable.

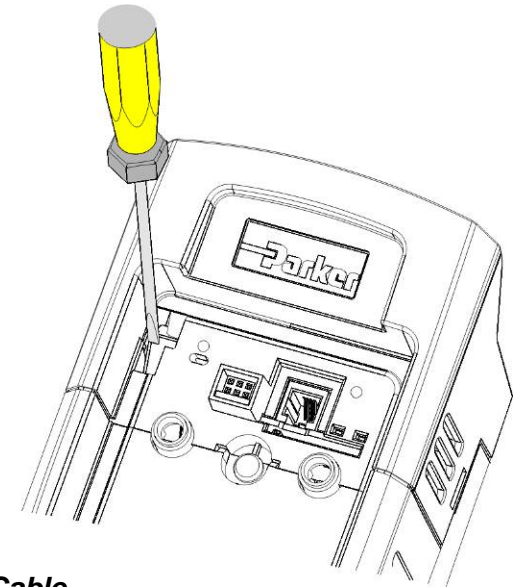
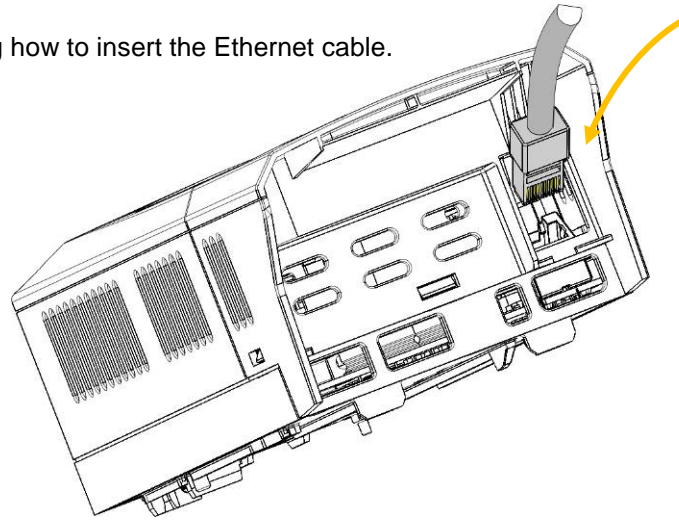

Disconnecting the Ethernet Cable

To remove the cable first remove the GKP and then insert a screwdriver to release the catch on the Ethernet clip.

Setting the IP Address

The AC30V Ethernet requires an IP address to participate in communications. The factory default is set so that an IP address is selected automatically depending on the network on which it is connected. It may obtain an IP address using DHCP or Auto-IP.

DHCP

If the network has a DHCP (Dynamic Host Communications Protocol) server, then the AC30V will obtain an address from this.

Auto-IP

If the network has no DHCP server or if connecting the AC30V directly to a PC then, after a timeout period, the IP address will be chosen randomly by the AC30V from the link-local address range 169.254.*.*. Note that when connecting the AC30V directly to a PC it may take 1 – 2 minutes for the PC to obtain a link-local address.

Manual

The IP address may be fixed if required. The DHCP and Auto-IP must both be disabled.

The current IP address of the AC30V may be monitored using the following parameters **0926 IP Address, 0927 Subnet Mask, 0928 Gateway Address**, found in menu;

Parameters::Base Comms::Ethernet

The state of the Ethernet may be monitored using the parameter **0919 Ethernet State** and from the Ethernet icon  on the GKP status bar.

The IP address may be used to access the AC30V via a web browser.

For more information on customizing and troubleshooting the AC30V Ethernet see Chapter 12 – Ethernet.

Information on using the Modbus TCP server can be found in Appendix A - Modbus TCP.

4-31 Installation

Firmware Update

UPDATING THE DRIVE FIRMWARE

Prepare SD card

Copy the new firmware to an SD card, ensure the file is named firmware.30x

New firmware is available at www.parker.com/ssd or can be copied from the Parker Drive Quicktool "Drive Maintenance" task.

Perform the upgrade

CAUTION: DO NOT REMOVE POWER FROM THE DRIVE DURING THE FIRMWARE UPDATE.

Insert the SD in the Drive's SD slot. Replace the GKP if necessary. The "Update Firmware" will now be visible in the main menu.

Once you select the "Update Firmware" menu you must edit **(1002) Update Firmware** to start the update, change the value from FALSE to TRUE.

The Drive will restart with the setup wizard once the process is complete.



Chapter 5: Associated Equipment

MAIN POINTS

Connect the associated equipment in the following order:

Frame E Illustrated

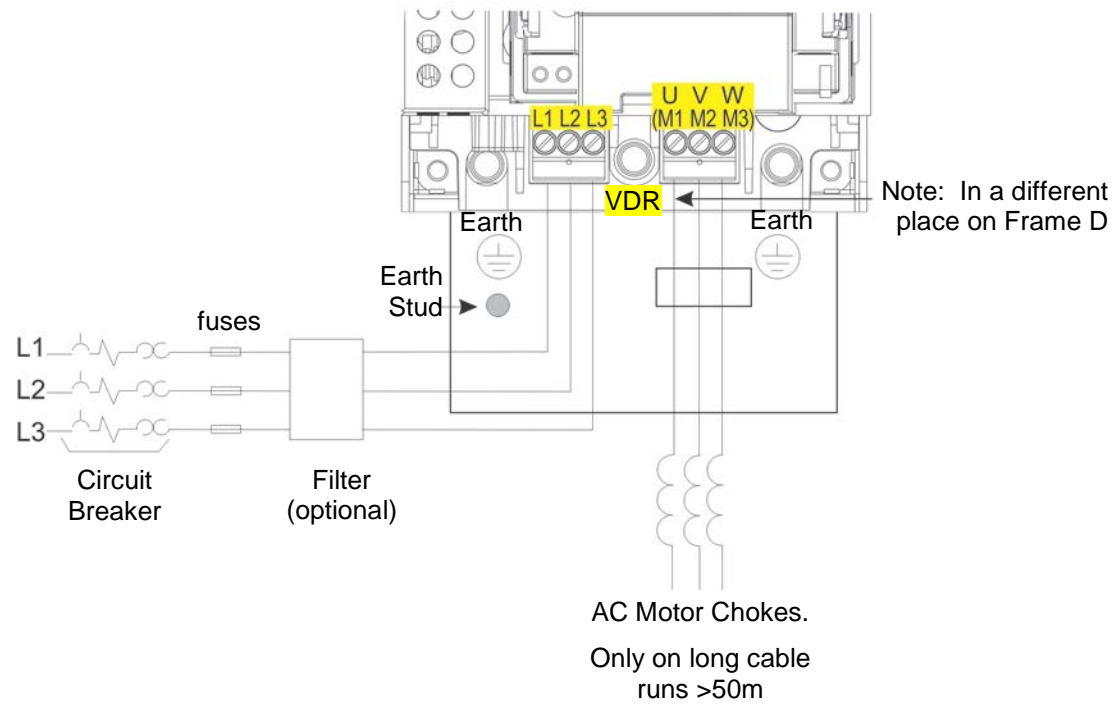
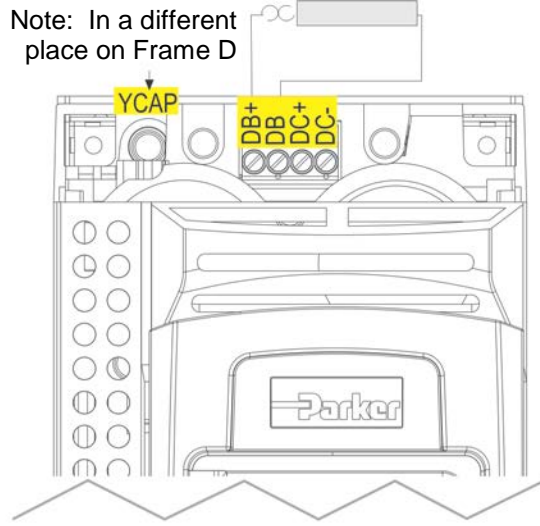

5-2 Associated Equipment

AC Motor Chokes

The maximum rate of rise of Volts (dv/dt) present on the motor terminals of the drive, can be as high as 10,000V/ μ s. This can be reduced by adding a motor choke in series with the motor.

Installations with long cable runs may suffer from nuisance overcurrent trips, refer to Appendix C Compliance - Cabling Requirements for maximum cable lengths. An output choke may be fitted in the drive output to limit parasitic capacitive current to earth. Screened cable has a higher parasitic capacitance to earth and may cause problems in shorter runs. Contact Parker for recommended choke values.

Motor Power (kW)	Choke Inductance	RMS Current Rating	Parker Part No.
0.75	2mH	7.5A	CO055931
1.1			
1.5			
2.2			
4.0	0.9mH	22A	CO057283
5.5			
7.5			
11	0.45mH	33A	CO057284
15			
18	0.3mH	44A	CO057285

Dynamic Braking Resistors

We can supply suitable braking resistors, found on the following pages. Alternatively, you can use the calculation on page 5-5 to help you select alternative resistors.

IMPORTANT We recommend using a thermal overload switch to protect the braking circuit. Refer to page 5-4.

- ◆ The AC30V unit must be fitted with external braking resistors if braking is required.

WIRING DETAILS

WARNING

Do not apply external voltage sources (mains supply or otherwise) to either of the braking terminals: DB+, DB. This can lead to damage to the drive and installation, and risk to personnel.

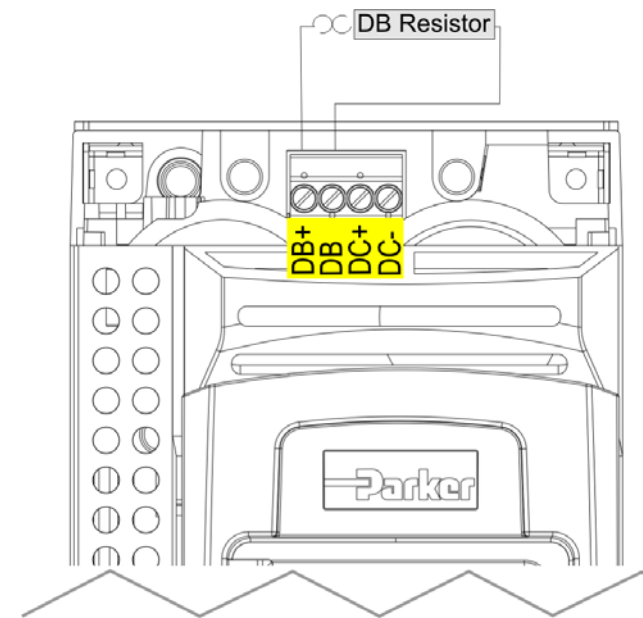

Figure 5.1 External Braking Resistor

5-4 Associated Equipment

Dynamic Braking Resistors

These resistor sets are designed for stopping the system at rated power. They are rated for 10 seconds in a 100 seconds duty cycle.

See Appendix F for Minimum Brake Resistor value for each individual drive size.

RESISTOR SELECTION

These small, metal-clad resistors should be mounted on a heatsink (back panel) and covered to prevent injury from burning.

There are four resistor values available.

IMPORTANT

The resistor can dissipate 10 x power rating for 5s, but the continuous rating should not be exceeded under repetitive loading.

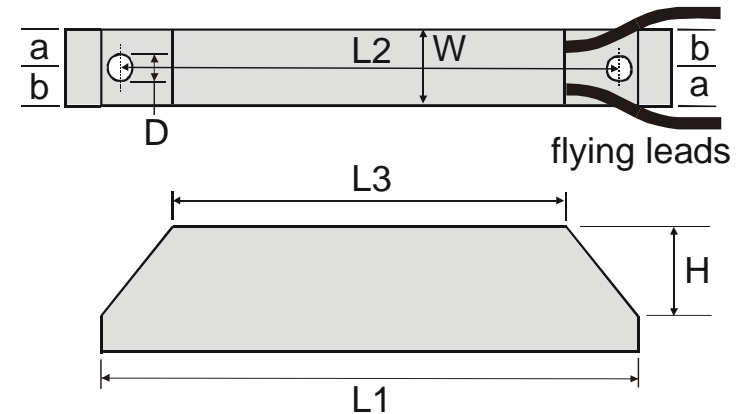

	Flying Lead Length	L1	L2	L3	a	b	D	W	H
500W	500	335	316	295	13	17	5.3	60	30
200W	500	165	146	125	13	17	5.3	60	30

Dimensions are in millimetres

Parker Part Number	Power Rating (W)	Resistance (Ω)	Continuous Current Rating (A)
CZ467717	200	100	1.4
CZ463068	200	56	1.9
CZ467716	500	56	3.0
CZ388396	500	36	3.7

Calculation

Brake resistor assemblies must be rated to absorb both peak braking power during deceleration and the average power over the complete cycle.

$$\text{Peak braking power } P_{pk} = \frac{0.0055 \times J \times (n_1^2 - n_2^2)}{t_b} \quad (\text{W})$$

$$\text{Average braking power } P_{av} = \frac{P_{pk}}{t_c} \times t_b$$

- J - total inertia (kgm²)
- n₁ - initial speed (rpm)
- n₂ - final speed (rpm)
- t_b - braking time (s)
- t_c - cycle time (s)

Obtain information on the peak power rating and the average power rating of the resistors from the resistor manufacturer. If this information is not available, a large safety margin must be incorporated to ensure that the resistors are not overloaded.

By connecting these resistors in series and in parallel the required braking capacity can be selected for the application.

IMPORTANT *The minimum resistance of the combination and maximum dc link voltage must be as specified in Appendix F: “Technical Specifications” - Internal Dynamic Brake Switch.*

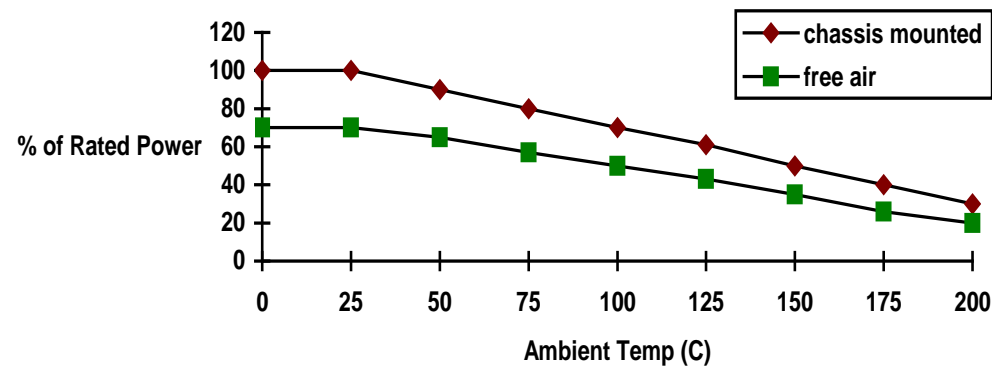

Figure 5.2 Braking Resistor Derating Graph (Metal Clad Resistors)

5-6 Associated Equipment

Circuit Breakers

We do not recommend the use of circuit breakers (e.g. RCD, ELCB, GFCI), but where their use is mandatory, they should:

- Operate correctly with dc and ac protective earth currents (i.e. type B RCDs as in Amendment 2 of IEC755).
- Have adjustable trip amplitude and time characteristics to prevent nuisance tripping on switch-on.

When the ac supply is switched on, a pulse of current flows to earth to charge the internal/external ac supply EMC filter's internal capacitors which are connected between phase and earth. This has been minimised in Parker SSD Drives' filters, but may still trip out any circuit breaker in the earth system. In addition, high frequency and dc components of earth leakage currents will flow under normal operating conditions. Under certain fault conditions larger dc protective earth currents may flow. The protective function of some circuit breakers cannot be guaranteed under such operating conditions.

WARNING

Circuit breakers used with VSDs and other similar equipment are not suitable for personnel protection.
Use another means to provide personal safety. Refer to EN50178 / VDE0160 / EN60204-1

External EMC Filters

Refer to Appendix C Compliance - Filters for complete information.

Filter Description	Filter Part Number
Frame D & E	
500V IT/TN	CO501894
Frame F	
500V IT/TN	CO501895

Input Chokes

For further information refer to Appendix F Technical Specifications “Supply Short Circuit Rating”.

Gaskets

Gaskets can be purchased from Parker using the following part numbers.

Frame Size	Gasket Part Number
Frame D	BO501911U001
Frame E	BO501911U002
Frame F	BO501911U003

For installation information see Chapter 4 ‘Installation’

Cabling Bracket for Control & Main Cable

Part numbers for the cabling brackets are:

Frame Size	Cabling Bracket Part Number
Frame D	LA501935U001
Frame E	LA501935U002
Frame F	LA501935U003

For further information see Chapter 4 ‘Installation’

5-8 Associated Equipment

Option Cards

There are a range of Option Cards that may come factory-fitted to the AC30V, or are available for customer fitting.

Refer to the Technical Manual supplied with each Option Card for detailed instructions.

Product Code	Description	Part Number
7004-01-00	General Purpose I/O Option, referred to as GPIO Digital Inputs or Outputs, Analogue Inputs, Motor Thermistor Input, Volt-free Relay Outputs, Real-Time Clock	HA501836U001
7004-02-00	GPIO - Motor Thermistor Input	HA501836U001
7004-03-00	GPIO - Motor Thermistor plus Real-Time Clock	HA501836U001
7003-PB-00	Profibus DP-V1	HA501837U001
7003-PN-00	PROFINET IO	HA501838U001
7003-DN-00	DeviceNet	HA501840U001
7003-CN-00	ControlNet	HA501936U001
7003-CB-00	CANopen	HA501841U001
7003-IP-00	EtherNet IP	HA501842U001
7003-EC-00	EtherCAT	HA501938U001
7003-BP-00	BACnet IP	HA501939U001
7003-BN-00	BACnet MSTP	HA501940U001
7003-RS-00	Modbus RTU	HA501839U001
7003-IM-00	Modbus TCP	HA501937U001
7003-CC-00	CC-LINK	HA501941U001

INSTALLATION DETAILS

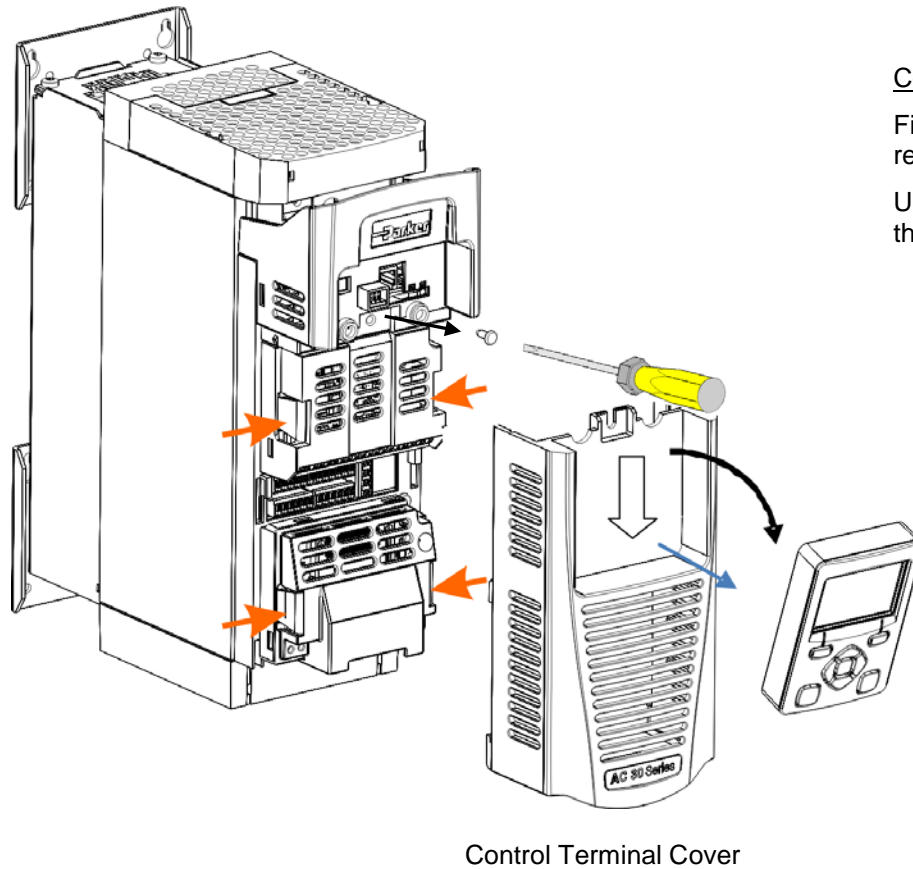

Control Terminal Cover Removal

First remove the GKP by pulling from the top down and remove.

Undo the screw and slide the control terminal cover down, then remove



HAZARDOUS VOLTAGES may be present on GPIO module motor thermistor user relays, please refer to the option technical manual or main product manual for safety information

5-10 Associated Equipment

Click the Option into place and tighten the retaining screw (as shown below).

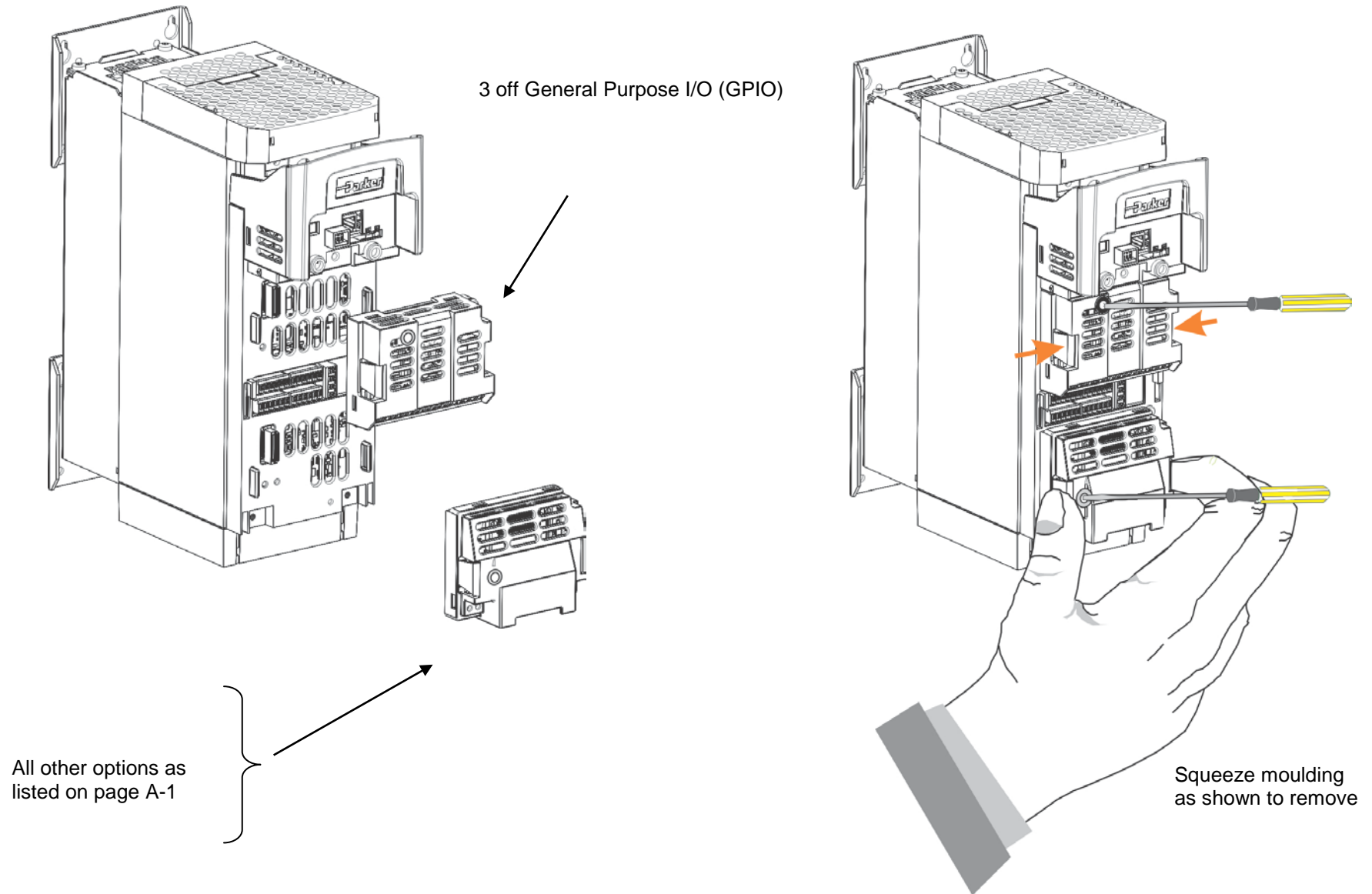

Chapter 6 Safe Torque Off SIL3/PLe

General Information



THIS EQUIPMENT IF USED INCORRECTLY IS POTENTIALLY DANGEROUS. THEREFORE UNDER NO CIRCUMSTANCES SHOULD IT BE USED BEFORE THESE INSTRUCTIONS HAVE BEEN READ AND UNDERSTOOD BY THE END USER WHO SHOULD BE APPROPRIATELY QUALIFIED TO OPERATE THE EQUIPMENT.

This section provides general information about Safe Torque Off (STO).

Two safety functions can be implemented with the AC30V: STO and Safe Stop 1 (SS1). In order to meet all aspects of STO and SS1, an external safety control unit should be used.

To implement Safe Stop 1 (SS1), the external safety control unit causes the drive to decelerate to rest. Once at rest, it invokes STO in the AC30V. Please refer to EN61800-5-2:2007 para 4.2.2.3 for the formal definitions.

It is the user's responsibility to:

- 1) Risk assess the machine.
- 2) Design, implement and assess an appropriate solution for each application to meet all relevant safety requirements.

Note: STO is an electronic inhibit intended for use during normal operation of the machine. It is not intended for use during machine maintenance, repair, replacement or other similar activities. For these activities recognised electrical power isolation devices and lock-off procedures should be used.

The AC30V STO function is a factory-fitted and factory-tested feature. See the section "Safety Warnings and Limitations" on page 6-17.

6-2 Safe Torque Off

STO FUNCTIONAL DESCRIPTION

STO is a means of preventing an AC30V drive from delivering rotational force to its connected electric motor. Please refer to EN61800-5-2:2007 para 4.2.2.2 for the formal definition.

To ensure a high degree of safety, two independent STO control channels are implemented in hardware. The STO circuit in the AC30V is designed such that a fault in one control channel will not affect the other channel's ability to prevent the drive from starting, i.e. the STO function of the AC30V drive is tolerant to any single fault. It may not be tolerant to an accumulation of faults. This is in keeping with its declared safety ratings.

STO always overrides any attempt to start the drive. If one or both STO control inputs is requesting the STO function, the drive will not start, even if for example, the drive's software malfunctions and tries to cause the motor to turn.

The STO function is implemented in hardware; it overrides all software activities. The only software involvement is to report STO status to the user via a Graphical Keypad (GKP), serial communications link or user terminal as defined by the drive configuration.



WARNING

THE DECLARED SIL/PL CAPABILITY OF THIS STO PRODUCT CAN BE ACHIEVED ONLY WHEN THE TWO STO USER INPUTS ARE DRIVEN INDEPENDENTLY. THEY MUST NOT BOTH BE DRIVEN FROM A COMMON SOURCE; OTHERWISE THE SINGLE FAULT DETECTION WILL BE COMPLETELY INOPERATIVE.

USE OF THE PRODUCT IN THIS "COMMON SOURCE" CONDITION INVALIDATES THE STO PRODUCT SPECIFICATION AND IS ENTIRELY AT THE USER'S OWN RISK.

Alignment to European Standards

EN ISO13849-1:2008

(Safety of machinery – Safety-related parts of control systems)

STO aligns internally to the following aspects of this standard:

- **Architecture according to Category 3:**

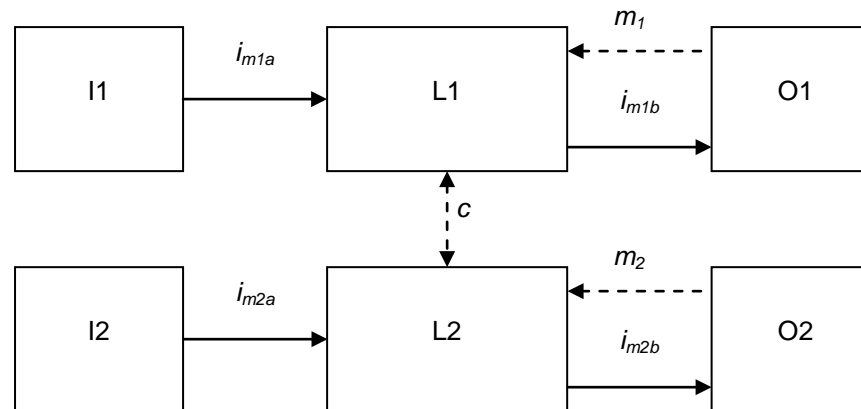

Solid lines represent the STO control paths.

Dashed lines represent reasonably practicable fault detection.

Key:

- I1, I2 = user terminal
- L1, L2 = logic
- O1, O2 = methods of enabling or disabling output power devices
- i_{mxy} = interconnecting means
- m_x = monitoring
- c = cross monitoring

- **Category 3 general requirements are:**

A single failure, and any consequential failures, will not lead to loss of the STO safety function.

Failure of more than one component can lead to the loss of the STO safety function.

6-4 Safe Torque Off

Most but not all single component failures will be detected. Diagnostic Coverage (DC) is required to be at least 60% (i.e. the minimum required for 'low' diagnostic coverage).

Detected component failures will result in the STO function being applied without intervention from the user.

The risk associated with the loss of STO safety function caused by multiple failures must be understood and accepted by the user.

The user must undertake a risk analysis and specify suitable components that, when connected together, meet the risk assessment requirements.

Mean Time To Failure (dangerous) (MTTFd) of each STO channel must be ≥ 30 years.

Common Cause Failure (CCF) score must be ≥ 65 according to Annex F of the standard.

- **Performance Level (PL) e:**

Average probability of dangerous failure per hour (PFH) must be $\leq 10^{-7}$

EN61800-5-2:2007 AND EN61508

(Adjustable speed electrical power drive systems) and

(Functional safety of electrical/electronic/programmable electronic safety-related systems)

STO aligns to the following aspects of this standard:

- Safety Integrity Level (SIL) 3

Probability of dangerous random hardware failures per hour (PFH) must be $\leq 10^{-7}$

Subsystems type A according to EN61508-2:2001 para 7.4.3.1.2

Hardware Fault Tolerance (HFT) = 1

Safe Failure Fraction (SFF) must be $\geq 90\%$

Safety Specification

As assessed to EN ISO13849-1 and EN61800-5-2 the AC30V has the following related safety values:-

Criterion	Requirement	Value achieved
SIL3	For type A subsystems, HFT = 1: SFF \geq 60%	SFF = 99%
SIL3	$10^{-7} \geq$ PFH \geq 10^{-8}	PFH = 2.3×10^{-9}
PLe	Category 3; PFH \leq $4,29 \times 10^{-8}$	PFH = 2.3×10^{-9}
PLe	30 years \leq MTTFd \leq 100 years	MTTFd = 100 years ¹
PLe	DC = medium	DC = Medium
Mission Time	20 years	20 years

Note: all values quoted in this table are valid only when the two STO user inputs are driven independently. This is as required by EN ISO 13849-1 category 3. See the Alignment to European Standards section in this chapter for the required architecture which must be used throughout the machine design relevant to the drive under consideration.

EMC Specification

In addition to the mandatory requirements of EN61800, the STO functionality has been subjected to testing for immunity at higher levels. In particular the STO function (only) has been tested for radiated immunity according to EN62061:2005 Annex E up to 2.7GHz which includes frequencies used by mobile telephones and walkie-talkies.

¹ EN ISO13849 limits MTTFd to 100 years.

6-6 Safe Torque Off

User Connections

The STO terminals are on a 6-way terminal block X10. This is mounted on the AC30V control housing. Terminal designations are:

Terminal Number	Terminal Name	Description
X10/01	STO A Input	0V or not connected = drive will not run, STO is active on channel A. 24V = drive is enabled to run if X10/03 is also 24V. This input is optically isolated from all other AC30V terminals except X10/02, X10/03 and X10/04.
X10/02	STO Common ²	Signal return for STO A Input and STO B Input. Connected internally to X10/04. This terminal or X10/04 must be connected to earth at one common point in the drive system.
X10/03	STO B Input	0V or not connected = drive will not run, STO is active on channel B. 24V = drive is enabled to run if X10/01 is also 24V. This input is optically isolated from all other AC30V terminals except X10/01, X10/02 and X10/04.
X10/04	STO Common ²	Signal return for STO A Input and STO B Input. Connected internally to X10/02. This terminal or X10/02 must be connected to earth at one common point in the drive system.
X10/05	STO Status A	Together with X10/06, this terminal forms an isolated solid-state relay output. This output is ON (equivalent to closed relay contacts) when the STO circuit is in the 'safe' state, i.e. the drive will not cause its motor to produce torque. However, this output should be used primarily as an indication. In the unlikely event of a fault in the STO circuit, this output could turn on erroneously to give a false indication of the STO status. It must not be used as a guarantee that the motor will not produce torque. The solid-state relay is protected by a self-resetting fuse.
X10/06	STO Status B	Together with X10/05, this terminal forms an isolated solid-state relay output. See the description for X10/05.

² Do not connect both X10/02 and X10/04 to earth, otherwise an earth loop could be created.

Examples of wiring to X10/05 and X10/06.

Active high output:

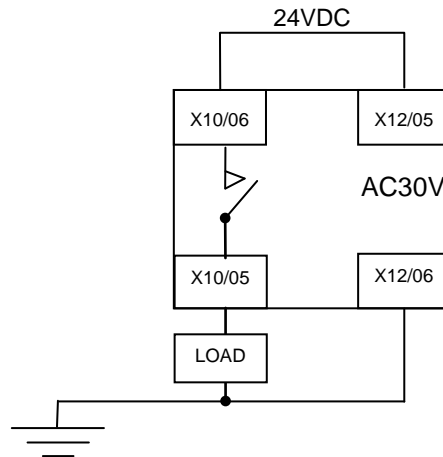

The load is energised and X10/05 is high when STO is in the intended safe STO state.

Active low output:

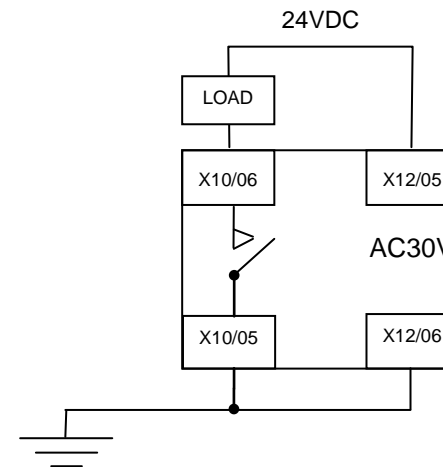

The load is energised and X10/06 is low when STO is in the intended safe STO state.

The examples show the use of the 24V supply provided on X12/05 (+24V) and X12/06 (0V) as source of power to a load. Alternatively an external 24V supply could be used.

Note: If a drive is powered from 24V only, i.e., 24V is applied to terminals X12/05 or X12/06 and the 3 phase power is off, the STO user output will still reflect the status of the two STO user inputs.

6-8 Safe Torque Off

STO Technical Specification

INPUTS SPECIFICATION

STO A Input and STO B Input comply with IEC61131-2. Note: inputs do not have hysteresis.

Recommended input voltage for low level:	0V to +5V
Recommended input voltage for high level:	+21.6V to +26.4V
Typical input threshold voltage:	+10.5V
Indeterminate input range:	+5V to +15V. Function is undefined.
Absolute maximum input voltage:	-30V to +30V
Typical input current @ 24V	9mA
Fault detection time ³ :	2.3sec typical; < 1.6sec will not generate a fault > 3.0sec will generate a fault.

³ A fault is defined in this context as STO A Input and STO B Input being sensed in opposite logic states.

OUTPUT SPECIFICATION

OFF state:

Maximum applied voltage:	$\pm 30\text{V}$ (X10/06 relative to X10/05)
Leakage current:	Less than 0.1mA.

ON state:

Maximum output current:	150mA
Overcurrent protection:	Included
Resistance between output terminals:	Less than 6Ω .

**WARNING**

WIRED CONNECTIONS TO TERMINALS X10/01, X10/03, X10/05 AND X10/06 MUST BE LESS THAN 25 METRES IN LENGTH AND REMAIN WITHIN THE CUBICLE OR DRIVE ENCLOSURE. PARKER IS NOT LIABLE FOR ANY CONSEQUENCES IF EITHER CONDITION IS NOT MET.

6-10 Safe Torque Off

TRUTH TABLE

Overview	STO Input A X10/01	STO Input B X10/03	Drive Function	STO Status Output X10/05, X10/06
STO Active	0V	0V	Drive cannot start or supply power to its motor. STO trip reported. This is the intended safe state of the product with correct dual-channel operation.	ON
Abnormal one-channel operation detection	24V	0V	Drive cannot start or supply power to its motor. STO trip reported. If either of these conditions persists for more than 3.0 seconds (the maximum fault detection time), the STO function will lock into a fault state. The drive cannot start until the fault is rectified; all power is removed and reapplied (both mains and any auxiliary 24V dc power).	OFF
	0V	24V	This is single channel operation and thus deemed not as intended for category 3 / PLe / SIL3 structure implementation.	
STO Inactive	24V	24V	Drive is enabled to run under software control. The drive can supply power to its motor.	OFF
Drive unpowered	Don't care	Don't care	Drive cannot start or supply power to its motor.	OFF

STO Input Timing Diagrams

IDEAL OPERATION

In ideal operation, both inputs X10/01 and X10/03 should change state simultaneously reflecting true dual-channel operation as intended.

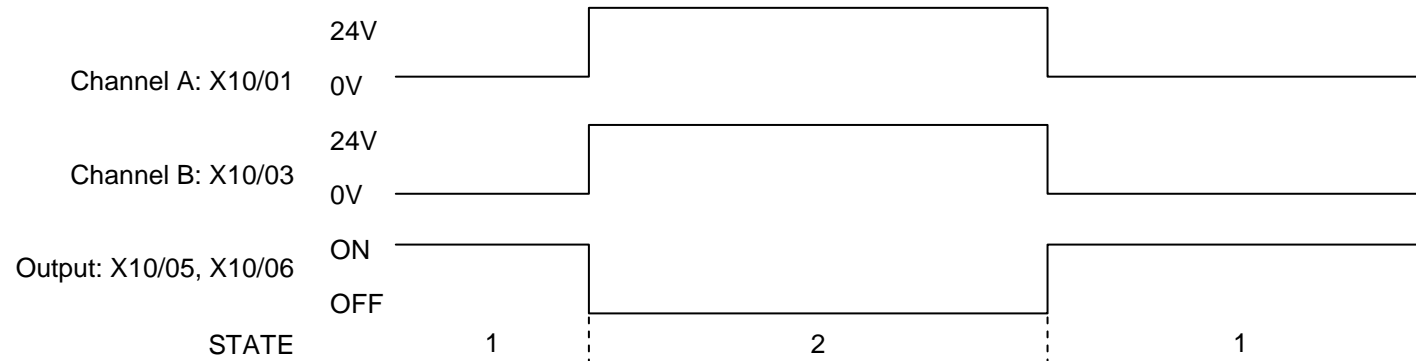

States:

- 1 Both inputs are low. Drive is tripped and STO prevents the drive from starting. User output is ON. This is the “safe torque off” state of the drive.
- 2 Both inputs are high. Drive is able to run under software control. User output is OFF.

6-12 Safe Torque Off

TYPICAL OPERATION

In typical operation, there can be a small time difference between changes of state on X10/01 and X10/03, due to different delays in the operation of two sets of relay contacts.

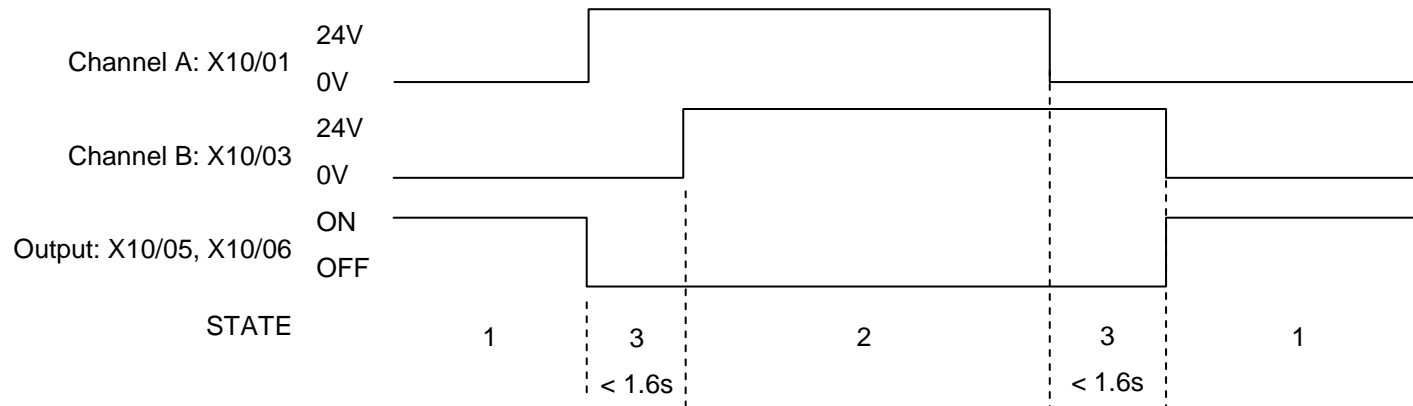

States:

- 1 Both inputs are low. Drive is tripped and STO prevents the drive from starting. User output is ON. This is the “safe torque off” state of the drive.
- 2 Both inputs are high. Drive is able to run under software control. User output is OFF.
- 3 One input is high and the other input is low. Drive is tripped and cannot start due to STO action. User output is OFF. Normal operation allows this state to persist for up to 1.6 seconds which is the minimum fault detection time required to generate a fault (3.0 seconds is the maximum). These tolerable time differences are normally caused by switches or relays; they should be kept as short as possible.

FAULT OPERATION

A fault is always detected when X10/01 and X10/03 are in opposite states for more than 3.0 seconds.

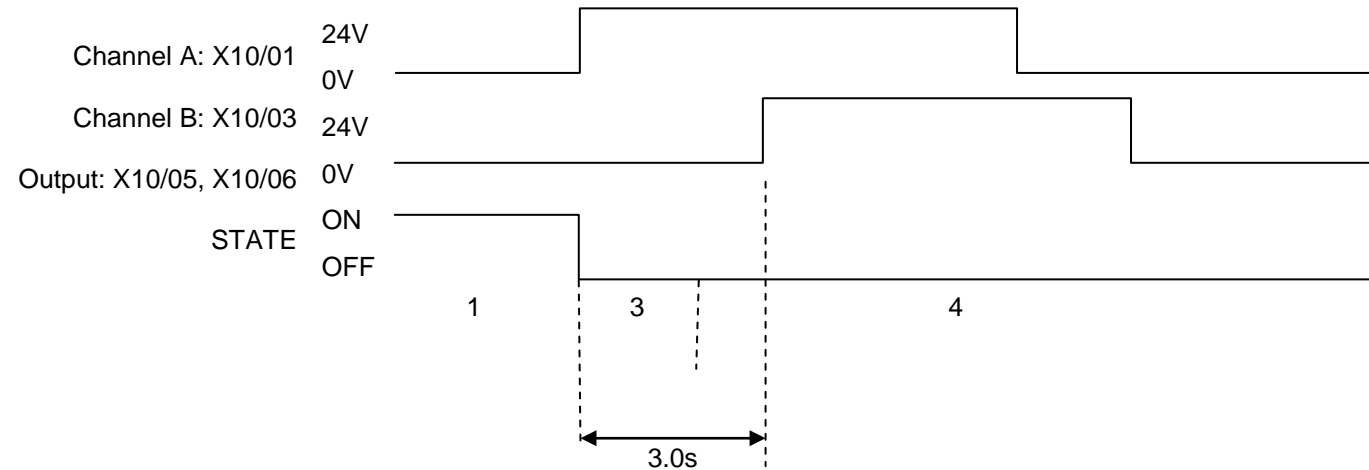

States:

- 1 Both inputs are low. Drive is tripped and STO prevents the drive from starting. User output is ON. This is the “safe torque off” state of the drive.
- 3 One input is high and the other input is low. Drive is tripped and STO prevents the drive from starting. In this example, this state persists for more than 3.0 seconds (being the maximum fault detection time), after which time the STO logic transitions to state 4 without further changes in input state. The AC30V has detected a fault or single-channel operation.
- 4 The fault state (one input high, the other input low) has persisted for longer than 3.0 seconds (being the maximum fault detection time). The STO hardware logic locks into state 4. The drive is tripped and the STO function prevents the drive from starting. User output is OFF. To exit from state 4, the drive must be powered off (all power removed including any auxiliary 24Vdc) and back on.



DANGER

OPERATION OF THE AC30V UNIT SHOULD CEASE IMMEDIATELY AND THE UNIT SHOULD BE RETURNED TO A PARKER AUTHORIZED REPAIR CENTRE FOR INVESTIGATION AND REPAIR.
FAILURE TO DO SO COULD RESULT IN INJURY, DEATH OR DAMAGE.

FURTHER OPERATION OF THE AC30V WITHOUT RESOLVING THIS FAILURE IS ENTIRELY AT THE USER'S OWN RISK.

SEE SAFETY CATEGORY DEFINITIONS AND LIMITATIONS, REFER TO EN ISO 13849-1:2008.

6-14 Safe Torque Off

PULSED INPUTS

Some safety equipment, e.g. safety PLCs, regularly pulse the two STO inputs independently in order to detect a short circuit between them. This is commonly known as OSSD (Output Signal Switch Device). The AC30V STO inputs are immune to such pulses when they are less than 2ms in width. The product will not react to such pulses and therefore will not inadvertently invoke the STO function.

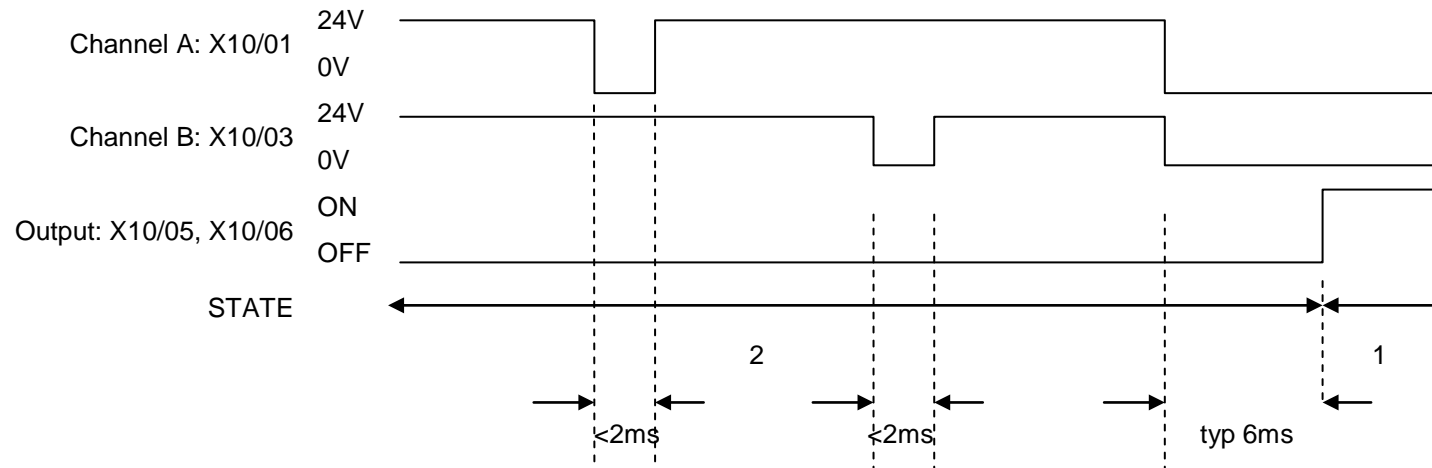

States:

- 1 Both inputs are low. Drive is tripped and STO prevents the drive from starting. User output is ON. This is the “safe torque off” state of the drive.
- 2 Both inputs are high, but regularly pulse low independently. External equipment can thus detect a short circuit between the two STO user inputs. Each input must remain low for 6ms (typical) before the AC30V reacts to it.

STO State Transition Diagram

The flow chart below shows how the drive responds to STO inputs, start and stop commands.

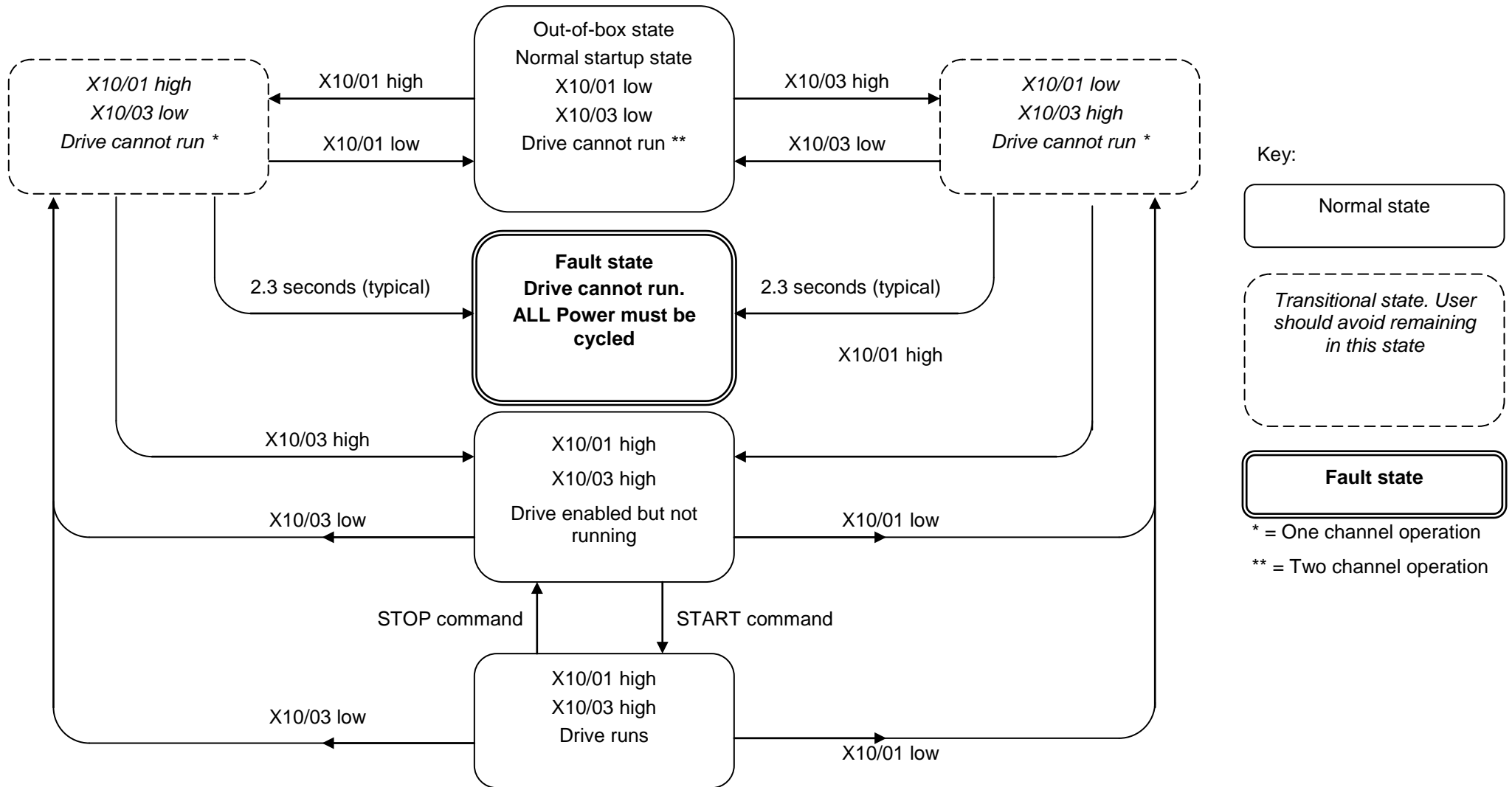

6-16 Safe Torque Off

STO Trip Annunciation

The GKP will display a STO trip message when STO becomes active, i.e. STO prevents the drive from starting, thus:

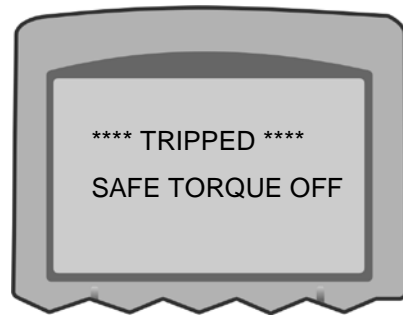

GKP Display

This message is displayed immediately if, on starting the drive or whilst the drive is running:

- One or both STO user inputs X10/01 or X10/03 is low when the user attempts to start the drive, or
- One or both STO user inputs X10/01 or X10/03 goes low while the drive is running, or
- The AC30V drive has detected a fault in the STO circuit.

Note: an out-of-box AC30V drive will report this trip if the drive, as supplied, has no connections to X10 when it is first started. Appropriate connections must be made to X10 to prevent this trip from occurring, as described elsewhere in this chapter. The user must decide if STO is to be permanently inactive, or to make use of the STO feature. If the STO feature is not required, see the “Applications that do not require STO function” section on page 6-20.

STO is inserted into the trips history buffer (see Chapter 10 Trips & Fault Finding) if STO is active when the drive is commanded to start or if STO becomes active while the drive is running, indicating an abnormal condition. The trips history buffer is not updated if STO becomes active while the drive is not running.

Note: The normal method of operation is for STO to become active while the drive is not running and the motor is stationary.

Appropriate, application specific risk assessment is necessary when STO is activated on rotating motors, moving loads or when external forces such as gravitation or inertial loads act on the motor.



Safety Warnings and Limitations



- Only competent personnel are permitted to install the STO function and commission it. They must disseminate and make available all appropriate instructions and documentation to all personnel who may come into contact with or operate the STO and provide suitable training on the AC30V to ensure it is operated in the correct manner and to avoid damage, injury or loss of life.
- The AC30V STO function is a factory-fitted and factory-tested feature. Repairs to AC30V STO featured-product are to be carried out only by Parker authorized repair centres. Any unauthorised attempt to repair or disassemble the product will render any warranty null and void, and STO integrity could be impaired. **PARKER WILL NOT ACCEPT ANY LIABILITY FOR FAILURE TO OBEY THESE INSTRUCTIONS OR FOR ANY CONSEQUENTIAL INJURY, DEATH, LOSS OR DAMAGE.**
- It is important that the AC30V product environment including all aspects of its CE conformance and IP etc., specified elsewhere in this manual, is maintained to ensure the safety integrity of the STO function.
- Should synchronous motors be operated in the field weakening range, operation of the STO function may lead to overspeed and destructive overvoltages as well as explosions in the drive. Therefore, the STO function must NEVER be used with synchronous drives in the field-weakening range. The user must ensure this condition is prevented.
- When using synchronous permanent magnet motors, shaft movement over a small angle is possible if two faults occur simultaneously in the power section of the drive. This depends on the number of motor poles. The maximum angle is:
 - Rotary motors: $360^\circ / \text{number of poles}$.
 - Linear motors: 180° electrically.
 It is the user's responsibility to assess, validate and safeguard as necessary against this potential hazard.
- If external forces can act on the motor and/or load to cause it to move, additional measures must be taken by the user to restrain it, for example a mechanical brake. Examples of external forces are suspended loads (effect of gravity), and other web-tensioning devices.
- The AC30V STO feature does not provide or guarantee any galvanic isolation in accordance with EN 60204-1:2006 A1:2009 Section 5.5. This means that the entire system must be isolated from the mains power supply with a suitable electrical isolation device before any drive or motor maintenance or replacement procedures are attempted. Note that even after the power has been isolated, dangerous electrical voltages may still be present in the AC30V drive. Safe discharge times and details are specified in Chapter 1 Safety of this manual.
- The STO function must not be used for electrical isolation of the AC30V drive and power. Whenever any personnel require to work on the drive, associated motor or other power items, they must always use recognised and suitable electrical isolation devices.
- Terminal X10/02 or X10/04 must be connected to earth at one common point in the drive system. For multi-drive systems this can be a shared earth point.
- The STO user output, serial communications or GKP messages relating to accessing or viewing any safety monitoring statuses are for information only and should not be relied on. They are not part of the drive module safety system and its associated PL/SIL declared ratings. Any customer use of these must be appropriately risk assessed in accordance with the relevant standards or regulations.
- The STO safety function must be tested regularly. The frequency should be determined by the machinery builder. An initial minimum frequency of once per week is suggested. Refer to page 6-26 and following pages.

6-18 Safe Torque Off

- When using an external safety control unit with adjustable time delay, for example when implementing an SS1 function, the time delay must be protected to prevent unauthorized adjustment. The adjustable time delay on the safety control unit must be set to a value greater than the duration of the braking ramp controlled by the AC30V with maximum load inertia and from maximum speed. Any external forces must also be considered, e.g. effects due to gravity.
- When implementing a SS1 function with the AC30V, the user is responsible for ensuring the drive's configuration will allow a controlled braking ramp to be initiated by the external safety device. This is particularly important when using serial link communications for normal control of the drive.
- During the active braking phase of SS1 or Stop category 1 (controlled stop with safely monitored time delay according to EN60204-1:2006), faulty operation of the drive must be allowed for. If a fault in the drive system occurs during the active braking phase, the load may coast to a stop or might even actively accelerate until expiration of the defined time delay. It is not the remit of this document to specify these measures. This is for the user to assess.
- When the AC30V detects either an internal STO fault or an external single-channel user fault, the user must immediately fully resolve the fault. The user must ensure dual-channel operation has been fully restored before attempting to use the AC30V STO safety feature.



DANGER

FAILURE TO DO SO COULD RESULT IN STO NOT BEING ACHIEVABLE, AND THUS THE MOTOR MAY ROTATE UNEXPECTEDLY AND COULD RESULT IN INJURY, DEATH OR DAMAGE. FURTHER OPERATION OF THE AC30V WITHOUT RESOLVING THIS FAILURE IS ENTIRELY AT THE USER'S OWN RISK. SEE SAFETY CATEGORY DEFINITIONS AND LIMITATIONS, REFER TO EN ISO 13849-1:2008.

- It is the user's responsibility to ensure that their overall control implementation recovers safely from supply loss or dips.
- In all instances it is the user's responsibility formally to perform suitable risk assessments, and invoke and fully validate the necessary risk reduction measures after having thoroughly understood the application, the drive product and its features. Of special relevance is to assess the risk of the two STO user inputs shorting together.

EXAMPLE USER WIRING



WARNING

THE WIRING EXAMPLES SHOWN IN THIS SECTION ARE FOR ILLUSTRATION ONLY. THEY ARE NOT TO BE CONSIDERED FINAL DESIGNS, NOR AS AN ATTEMPT TO CREATE A DESIGN FOR SPECIFIC SOLUTIONS.

THE USER / INSTALLER IS RESPONSIBLE FOR DESIGNING A SUITABLE SYSTEM TO MEET ALL REQUIREMENTS OF THE APPLICATION INCLUDING ASSESSING AND VALIDATING IT. PARKER WILL NOT ACCEPT ANY LIABILITY FOR FAILURE TO DO THIS OR FOR ANY CONSEQUENTIAL LOSS OR DAMAGE.

6-20 Safe Torque Off

APPLICATIONS THAT DO NOT REQUIRE STO FUNCTION

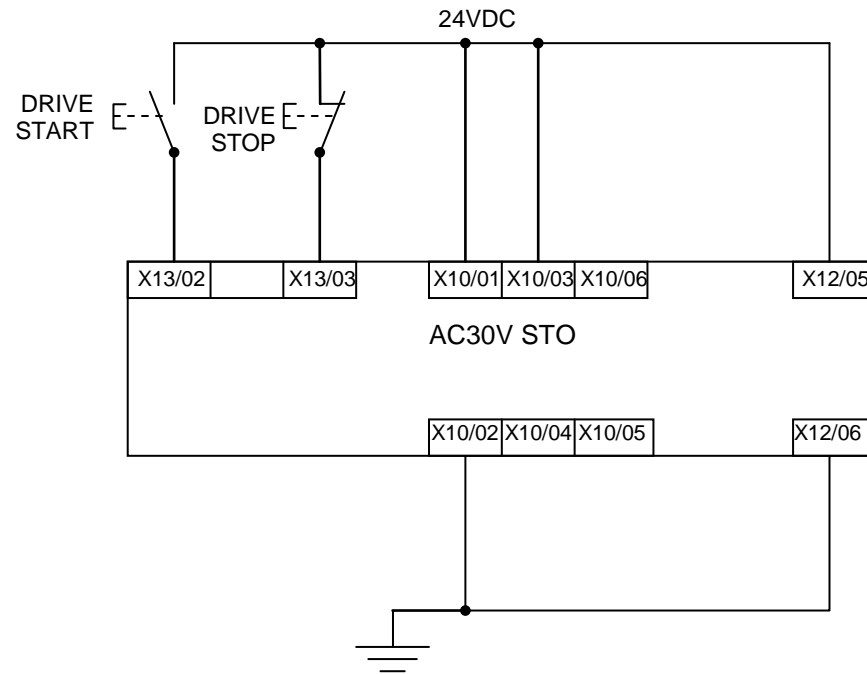

STO inputs X10/01 and X10/03 must be connected to 24VDC with respect to terminals X10/02 or X10/04.

STO Status output on X10/05 and X10/06 may be left disconnected.

All wiring shown is within the control cubicle.

Here the STO inputs X10/01 and X10/03 have been set to the inactive state (tied to +24V). Drive control is performed solely through software with no inherent safety function. The drive is controlled with its own start and stop pushbuttons.

Note: Only X10/02 or X10/04 must be earthed, i.e. they should not both be earthed otherwise it is possible to create an earth loop.

MINIMUM STO IMPLEMENTATION

This example shows the minimum connections required. To reset from STO requires that STO Request contacts are closed to permit normal drive operation. The user must do a risk assessment to ensure that all safety requirements are met. The user must select and assess appropriate equipment.

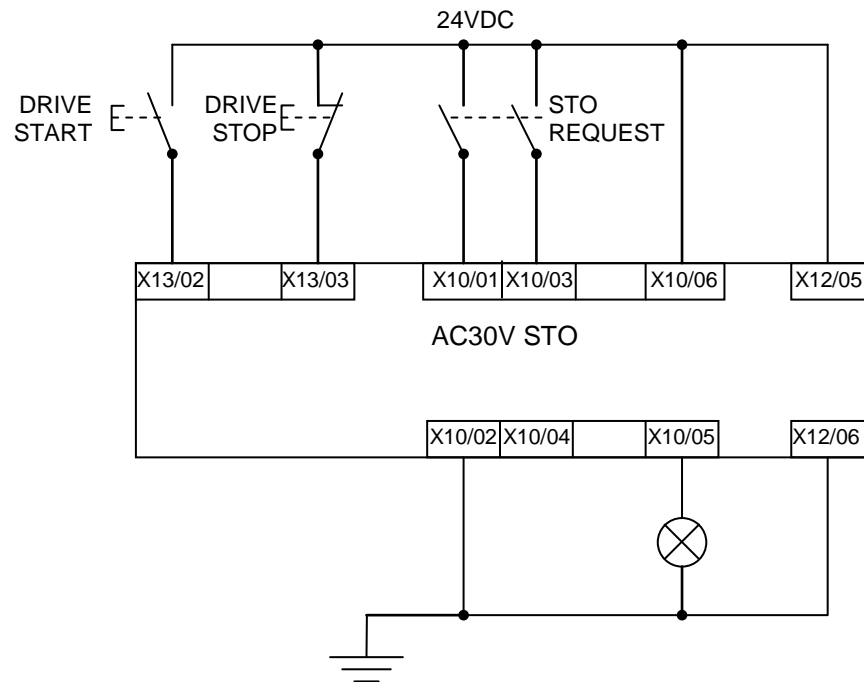

Note: all wiring shown is within the control cubicle.

To run the drive:

Ensure the STO Request contacts are closed.

Press the DRIVE START button.

To perform operational (not STO) stop:

Press the DRIVE STOP button.

Wait for the motor to come to rest.

To invoke STO:

Press the DRIVE STOP button.

Wait for the motor to come to rest.

Open the STO Request contacts simultaneously. The contacts must remain open for the entire duration that STO is required: they must not be momentary action switches. The drive will confirm via X10/05 that STO has been invoked by the lamp being ON.

If the lamp is OFF, do not access the machine as a fault may be present.

Note: if the STO Request contacts open while the motor is rotating, the motor will coast to rest (unless external forces act on it).

6-22 Safe Torque Off

STO IMPLEMENTATION WITH SAFETY CONTROL UNIT

This example improves on the previous one by showing the resetting from a STO stop. The example shows wiring and terminal numbering for a Siemens 3TK2827, but similar products are available from other vendors. Use of this Siemens part does not imply it is suitable for the user's application. The user must select and assess appropriate equipment.

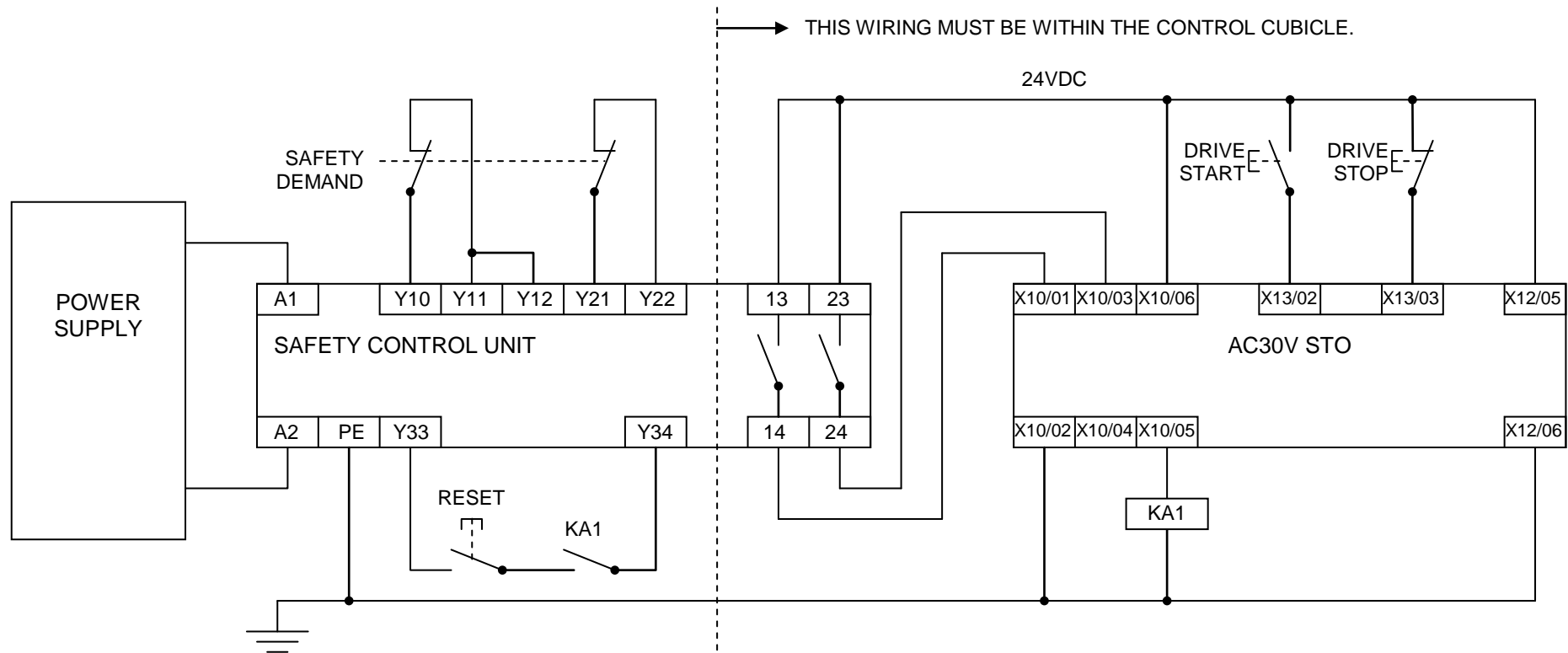

Note: On power-up, the safety control unit outputs are OPEN; thus the STO state is requested of the AC30V. The latter responds by energising KA1 if both channels are active and healthy. KA1 is used as a self-check for the reset cycle of the safety control unit. If a reset cannot be achieved due to KA1 being de-energised, a fault may be present and must be resolved by the user before relying on the STO function. See Fault Operation on page 6-13.

To start the drive:

Ensure the Safety Demand switch is reset (contacts closed). Press the RESET button to ensure the Safety Control Unit is reset; its contacts to the AC30V should close making the STO function inactive. The AC30V STO output should then turn OFF. Then press the DRIVE START button.

To perform operational stop (non STO):

Press the DRIVE STOP button.

Wait for the motor to come to rest.

To invoke STO:

Press the DRIVE STOP button.

Wait for the motor to come to rest.

Operate the Safety Demand switch (contacts open) that causes the safety control unit to open its output contacts together. In response, the drive will confirm, by energising KA1 via X10/05, that STO has been invoked. The user may wish / require that this is verified by mechanisms not shown on this drawing.



DANGER

IF KA1 IS DE-ENERGISED, DO NOT ACCESS THE MACHINE AS A FAULT MAY BE PRESENT.

THE USER MUST RESOLVE THE DETECTED FAULT BEFORE USING THE STO FEATURE. FAILURE TO DO SO COULD RESULT IN STO NOT BEING ACHIEVABLE, AND THUS THE MOTOR MAY ROTATE UNEXPECTEDLY AND COULD RESULT IN INJURY, DEATH OR DAMAGE. PARKER WILL NOT ACCEPT ANY LIABILITY FOR FAILURE TO DO THIS OR FOR ANY CONSEQUENTIAL LOSS OR DAMAGE.

Note: if either channel of the Safety Demand is requested while the motor is rotating, the motor will coast to rest unless external forces act on it.

6-24 Safe Torque Off

SS1 IMPLEMENTATION USING SAFETY CONTROL UNIT

This Safe Stop 1 (SS1) implementation causes the drive to come to rest in a controlled manner, and STO is actioned after a time delay determined by the safety delay relay. This conforms to SS1 defined in EN61800-5-2:2007 para 4.2.2.3 c). The example shows wiring and terminal numbering for a Siemens 3TK2827, but similar products are available from other vendors. Use of this Siemens part does not imply it is suitable for the user's application. The user must select and assess appropriate equipment.

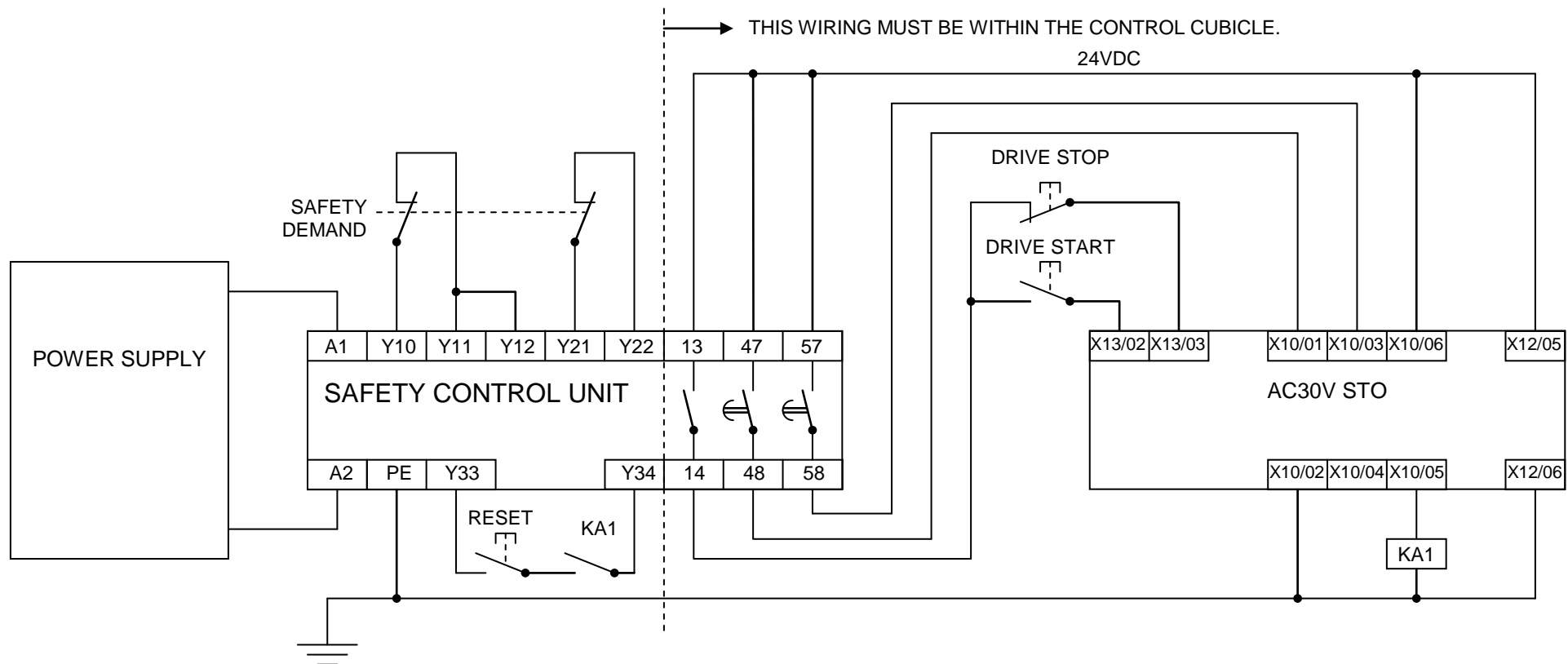

Note: On power-up, the Safety Control Unit outputs are OPEN; thus STO is requested of the AC30V. This responds by energising KA1 if both channels are active and healthy. KA1 is used as a self-check for the reset cycle of the Safety Control Unit. If a reset cannot be achieved due to KA1 being de-energised, a fault may be present and must be resolved by the user before relying on the STO function. See Fault Operation on page 6-13.

To start the drive:

Ensure the Safety Demand switch is reset (contacts closed). Press the RESET button to ensure the Safety Control Unit is reset; its contacts to the AC30V should close making the STO function inactive. The AC30V STO output should then turn OFF. Then press the DRIVE START button.

To perform operational stop (non STO):

Press the DRIVE STOP button.

Wait for the motor to come to rest.

To invoke SS1:

Operate the Safety Demand switch (contacts open). This should cause the Safety Control Unit to open its instantaneous output, shown here as a single channel. This causes the drive to decelerate to rest using its own software which is not safety critical in this instance. Note: the drive's block diagram must be configured to provide this ramp to rest functionality.

After a time delay set in the Safety Control Unit, the pair of delayed OFF output contacts open together. This time delay must be set longer than the worst case time for the motor to come to rest.

In response, the drive will confirm, by energising KA1 via X10/05, that STO has been invoked. The user may wish / require that this is verified by mechanisms not shown on this drawing.



DANGER

IF KA1 IS DE-ENERGISED, DO NOT ACCESS THE MACHINE AS A FAULT MAY BE PRESENT.

THE USER MUST RESOLVE THE DETECTED FAULT BEFORE RELYING FURTHER ON THE STO FEATURE. FAILURE TO DO SO COULD RESULT IN STO NOT BEING ACHIEVABLE, AND THUS THE MOTOR MAY ROTATE UNEXPECTEDLY AND COULD RESULT IN INJURY, DEATH OR DAMAGE. PARKER WILL NOT ACCEPT ANY LIABILITY FOR FAILURE TO DO THIS OR FOR ANY CONSEQUENTIAL LOSS OR DAMAGE.

Note: if either of the delayed OFF output contacts in the Safety Control Unit open while the motor is rotating, the motor will coast to rest (unless external forces act on it).

6-26 Safe Torque Off

STO Function Checking

Two levels of checking are required: a comprehensive check and a regular check.

The user / machine builder must determine the frequency of these checks based on their knowledge, use of the machine, appropriate standards and any legal requirements.



DANGER

ALL TESTS MUST PASS. IF ANY TEST FAILS, IT MUST BE INVESTIGATED AND RECTIFIED BEFORE ATTEMPTING TO PUT THE EQUIPMENT INTO SERVICE.

FURTHER OPERATION OF THE AC30V WITHOUT RESOLVING THIS FAILURE IS ENTIRELY AT THE USER'S OWN RISK. FAILURE TO DO SO COULD RESULT IN INJURY, DEATH OR DAMAGE. PARKER WILL NOT ACCEPT ANY LIABILITY FOR FAILURE TO DO THIS OR FOR ANY CONSEQUENTIAL LOSS OR DAMAGE.

SEE SAFETY CATEGORY DEFINITIONS AND LIMITATIONS, REFER TO EN ISO 13849-1:2008.

When STO becomes active during any test, power to the motor must be seen by the user to be quenched instantaneously. Note: the drive should respond in less than 10 milliseconds.

All STO checks should be performed after the AC30V has been commissioned for speed control.

Comprehensive Check

A comprehensive check of the STO function ensures the overall integrity of the STO functionality. It proves the independent operation of each channel individually (including during the normal dual channel operation), the STO user feedback operation, and the essential single fault detection.

It must always be performed:

- During factory test
- During commissioning activities
- After repair or replacement of the AC30V
- After any hardware or software design changes which may affect the AC30V concerned.
- After each intervention into the system and control wiring.
- At defined maintenance intervals as determined by the machine builder and /or user risk assessments and associated verification assessments.
- If the machine has been idle for more than a period of time determined by the machinery builder and user risk assessments.

The check must be made by suitably qualified professional personnel following all necessary safety precautions. They must be fully conversant with all equipment concerned.

NOTE: In the following text where it is required that “all power” is removed. Remove power and wait 5 minutes.

The performance of the individual test steps of the STO function should be logged.



WARNING

DURING THIS TEST, THE SAFETY FUNCTION MUST NOT BE RELIED ON BECAUSE AT TIMES ONLY ONE CHANNEL WILL BE ACTIVATED AND THEREFORE THE INTENDED SAFETY FUNCTION MAY NOT BE AVAILABLE.

ALSO STO WILL BE ACTIVATED WHILE THE MOTOR IS ROTATING, WHICH IS NOT THE NORMAL OPERATION.

THEREFORE THE USER MUST ENSURE IT IS SAFE TO DO THIS TEST BY USING AN APPROPRIATE RISK ASSESSMENT AND TAKING ANY ADDITIONAL RISK REDUCTION MEASURES.

6-28 Safe Torque Off

THE FOLLOWING TEST STEPS MUST BE PERFORMED:

Initial Check:

STO test	Comprehensive Check, Activity	Expected reaction and effect
1	Ensure that no harm can come to personnel or equipment if the motor turns.	
2	Apply +24V DC to terminals X10/01 and X10/03.	
3	Switch on power to the drive.	No error must be present in the drive system. X10/05 and /06 must be OFF.
4	Configure the drive and associated equipment if necessary so that it can be started and stopped, and a speed setpoint provided.	No error must be present in the drive system. X10/05 and /06 must be OFF.
5	Try to start the drive with a non-zero setpoint. This setpoint value will be referred to as SPT1 for brevity in these tests. Leave this set throughout all tests.	Drive must start and motor must turn at SPT1. X10/05 and /06 must be OFF.

Channel A Check:

STO test	Comprehensive Check, Activity	Expected reaction and effect
6	With drive running and motor turning at SPT1, momentarily disconnect terminal X10/01 (maximum duration of disconnect = 1 second), while retaining +24V at terminal X10/03.	Motor must immediately coast to rest. Drive must report STO trip immediately. X10/05 and /06 must remain OFF.
7	Ensure terminals X10/01 and X10/03 are both 24V. Try to restart the drive.	Drive must restart at SPT1. STO trip must clear. X10/05 and /06 must remain OFF.

Channel B Check:

STO test	Comprehensive Check, Activity	Expected reaction and effect
8	With drive running and motor turning at SPT1, momentarily disconnect terminal X10/03 (maximum duration of disconnect = 1 second), while retaining +24V at terminal X10/01.	Motor must immediately coast to rest. Drive must report STO trip immediately. X10/05 and /06 must remain OFF.
9	Ensure terminals X10/01 and X10/03 are both 24V. Try to restart the drive.	Drive must restart at SPT1. STO trip must clear. X10/05 and /06 must remain OFF.

6-30 Safe Torque Off

Channel A Fault Check:

STO test	Comprehensive Check, Activity	Expected reaction and effect
10	Ensure the drive is running and the motor is turning at SPT1. Disconnect terminal X10/01 for approximately 5 seconds (must exceed 3 seconds).	Motor must immediately coast to rest. Drive must report STO trip immediately. X10/05 and /06 must remain OFF.
11	The STO function has latched in hardware to disable the drive. Re-apply 24V to terminal X10/01, and then try to restart drive.	Drive must not start. Drive must continue to report STO trip. X10/05 and /06 must remain OFF.
12	Remove and re-apply all power to the drive	X10/05 and /06 must be OFF.
13	Try to restart drive at SPT1.	Drive must start at SPT1. X10/05 and /06 must remain OFF.

Channel B Fault Check:

STO test	Comprehensive Check, Activity	Expected reaction and effect
14	Ensure the drive is running and the motor is turning at SPT1. Disconnect terminal X10/03 for approximately 5 seconds (must exceed 3 seconds).	Motor must immediately coast to rest. Drive must report STO trip immediately. X10/05 and /06 must remain OFF.
15	The STO function has latched in hardware to disable the drive. Re-apply 24V to terminal X10/03, and then try to restart drive.	Drive must not start. Drive must continue to report STO trip. X10/05 and /06 must remain OFF.
16	Remove and re-apply all power to the drive	X10/05 and /06 must be OFF.
17	Try to restart drive at SPT1.	Drive must start at SPT1. X10/05 and /06 must remain OFF.
18	Stop the drive.	Drive must decelerate to rest. X10/05 and /06 must remain OFF.

User Output Check:

STO test	Comprehensive Check, Activity	Expected reaction and effect
19	Remove connections to X10/01 and X10/03 within 1 second of each other.	X10/05 and /06 must be ON.
20	Try to restart the drive. Wait for at least 10 seconds with the run command active, then remove it.	Drive must not start while run command is given. Drive must report STO trip immediately. X10/05 and /06 must remain ON.
21	Reconnect X10/01 and X10/03 to 24V.	X10/05 and /06 must turn OFF immediately.
22	Try to restart the drive at SPT1.	STO trip must clear. The drive must restart at SPT1.
23	Stop the drive. Test is complete.	Drive must stop.

The tests specified above are the minimum set; further test steps may be required depending on the application, for example a controlled stop should be verified in a SS1 application.

6-32 Safe Torque Off

REGULAR CHECK

A comprehensive check must take precedence if it coincides with a regular check.

A regular check is intended only to demonstrate the STO is functional. It will not always detect the loss of a single channel. It is therefore important for the user and / or machinery builder to determine the frequency of the comprehensive checks based on their knowledge and application of the machine.

The following tests should be performed.

STO test	Regular Check, Activity	Expected reaction and effect
1	Ensure that no harm can come to personnel or equipment if the motor turns.	
2	Apply +24V DC to terminals X10/01 and X10/03.	No error must be present in the drive system
3	Apply power to the drive.	X10/05 and /06 must be OFF. No error must be present in the drive system.
4	Try to start the drive with a non-zero setpoint. This setpoint value will be referred to as SPT1 for brevity in these tests. Leave this set throughout all tests.	The drive should start and the motor should turn at SPT1. X10/05 and /06 must remain OFF.
5	Disconnect X10/01 and X10/03 within 1 second of each other and leave disconnected for approximately 5 seconds (must exceed 3 seconds)..	Drive must stop immediately, and report STO trip. X10/05 and /06 must be ON.
6	Re-apply 24V to X10/01 and X10/03.	STO trip indication must remain. X10/05 and /06 must turn OFF.
7	Try to restart drive.	STO trip indication should clear. Drive must restart at SPT1.
8	Stop the drive. Test is complete.	Drive must stop.

Troubleshooting

Symptom	Examine:			Probable cause	Remedy
	GKP display	User output ⁴	User inputs ⁵		
Drive won't start when given a start command	*** TRIPPED *** SAFE TORQUE OFF	On	Both < 15V	STO is invoked.	When safe to do so, connect X10/01 and X10/03 to 24V ± 10%
	*** TRIPPED *** SAFE TORQUE OFF	Off	Both >15V and < 30V	Fault latch might have tripped	Remove all power from drive and re-apply. If symptom persists, immediately return the AC30V for repair. See the DANGER box below.
	Any other trip message, e.g. overvoltage	Off	Both >15V and < 30V	Drive is tripped, but not due to STO.	Reset the trip, and remove its cause. If symptom persists, return the AC30V for repair.
	Any other message	Off	Both >15V and < 30V	Faulty hardware	Return for repair
Drives starts unexpectedly	Don't care	Don't care	Both < 5V	Faulty hardware	Immediately return the AC30V for repair. See the DANGER box below.
	Don't care	Off	Both > 5V	STO not invoked by the user.	Use STO according to instructions elsewhere in this chapter.
Drive fails comprehensive or regular STO test	Don't care	Don't care	Don't care	Faulty hardware	Immediately return the AC30V for repair. See the DANGER box below.

The table above is only a guide. It may not be a comprehensive list of all possible symptoms relating to STO. Parker will not accept responsibility for any consequences arising from its incompleteness or inaccuracy.

Important note:

- There are no user-serviceable parts in the AC30V drive. Refer to the Safety Warnings and Limitations section on page 6-17 of this chapter.

⁴ Continuity through X10/05 and X10/06

⁵ Measure X10/01 and X10/03 relative to X10/02 or X10/04

6-34 Safe Torque Off



DANGER

IF ANY FAULTY OPERATION OF THE STO FUNCTION IS OBSERVED OR SUSPECTED, OPERATION OF THE AC30V SHOULD CEASE IMMEDIATELY AND THE UNIT SHOULD BE RETURNED TO PARKER FOR INVESTIGATION AND REPAIR. FAILURE TO DO SO COULD RESULT IN INJURY, DEATH OR DAMAGE.

FURTHER OPERATION OF THE AC30V WITHOUT RESOLVING THIS FAILURE IS ENTIRELY AT THE USER'S OWN RISK.

SEE SAFETY CATEGORY DEFINITIONS AND LIMITATIONS. REFER TO EN ISO 13849-1:2008

Chapter 7: The Graphical Keypad



The AC30V is fitted with a Graphical Keypad referred to throughout as GKP.

It provides for local control of the drive, monitoring, and complete access for application programming.

Insert the Keypad into the front of the drive (replacing the blank cover); or if supplied separately to be used remotely, up to 3 meters away, use the mounting kit with connection lead, see Chapter 4 for full details.

For remote installation refer to page 4-14 Fitting a Remote GKP.

7-2 The Graphical Keypad

Overview







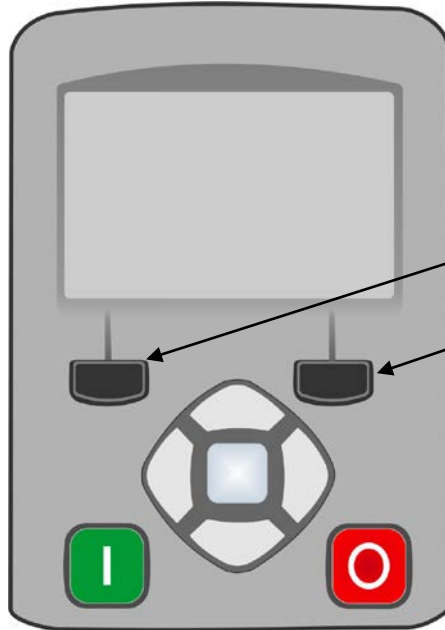

- The top line of the display is used to show the drive status
- The central region of the display shows the selected parameters or navigation menu
- The bottom line of the display indicates the action associated with the soft keys
- The actions of the soft keys are context dependent
- The central navigation and editing keys are referred to as UP, DOWN, LEFT, RIGHT and OK
- The Start, (green), and Stop, (red), keys are used to start and stop the motor when the drive is in local control mode.

Keypad

The nine keys of the Graphical Keypad are divided into three groups. These are the Start and Stop keys, the soft keys and the central navigation and editing keys



Key	Operation	Description
	START	Only operates when Local start / stop control mode is active <i>Control</i> Runs the motor
	STOP	<i>Control</i> Stops the motor when local start / stop control mode is active. <i>Trip reset</i> Resets any trips.
Soft Key 1		<i>Navigation</i> Displays the previous level's menu <i>Edit</i> Aborts the edit, leaving the value unchanged
Soft Key 2		Changes the control mode
	OK	<i>Navigation</i> Displays the next menu level or parameter. <i>Edit</i> Changes to edit mode when a parameter is selected. Accepts the value of the displayed parameter Long Press, (greater than 1s): Displays information about the selected parameter.
	UP	<i>Navigation</i> Moves up through the list of parameters <i>Edit</i> Increments the value of the displayed parameter
	DOWN	<i>Navigation</i> Moves down through the list of parameters <i>Edit</i> Decrements the value of the displayed parameter
	LEFT	<i>Navigation</i> Displays the previous level's menu <i>Edit</i> Selects the digit to be changed
	RIGHT	<i>Navigation</i> Displays the next menu level or parameter <i>Edit</i> Selects the digit to be changed

7-4 The Graphical Keypad

The Display

The display is divided into three areas. The top line shows a summary of the drive status, the centre region is the main work area and the bottom line is used to indicate the action associated with the soft keys.

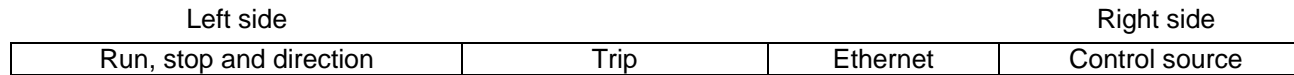

DRIVE STATUS SUMMARY

The top line of the display shows a summary of the drive status. This is divided into four regions. Each region is dedicated to a particular status indication, as shown.



The individual status conditions are indicated pictorially:



Run, Stop and Direction

Running in the positive direction	
Running in the negative direction	
Stopped, (ready to run in the positive direction)	
Stopped, (ready to run in the negative direction)	



Trip

Drive tripped, (indication flashing)	
--------------------------------------	-------------------------------------------------------------------------------------

Ethernet

IP Address missing, (indication flashing)	
IP Address configured	

Control source

Start / stop control from the keypad	
Start / stop control from the terminals	
Start / stop control from a communications master	

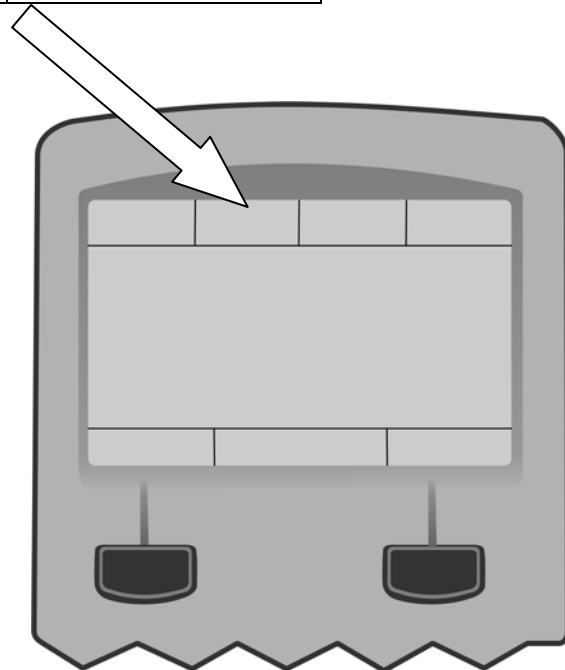

SOFT KEY ACTION INDICATION

The use of Soft Key 1 and Soft Key 2 is indicated on the bottom line of the display by the icon shown above the key.

Soft Key 1

Soft key 1 is used as return or abort.

Return:	
Abort	

When navigating around the menu tree, the return function navigates to the previous level. In this case the return is the opposite of the OK key.

When changing a parameter value the Abort key discards any modifications and leaves the parameter unchanged.

Soft Key 2

Soft key 2 is used to select the source for stop / start control

Toggle between Local and Remote modes	
---------------------------------------	--

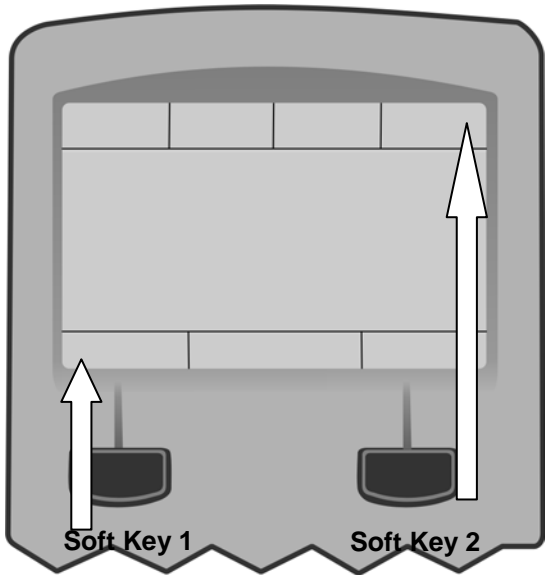

LEDS

The Graphical Display has two light emitting diodes, one illuminates the green start key, and one illuminates the red stop key. Each LED may be independently off, on or flashing.

Start key LED	Stop key LED	Description
OFF	Flashing	Stopping
OFF	ON	Stopped
ON	OFF	Running
Both flashing		The drive is not in its OPERATIONAL state
Flashing Green then Red		The drive is in a FAULT state



7-6 The Graphical Keypad

The Menu System

NAVIGATING THE MENU SYSTEM

The Menu System can be thought of as a map which is navigated using the direction keys.

- Use the left and right keys to navigate through the menu levels.
- Use the up and down keys to scroll through the Menu and Parameter lists

Menus can contain other menus at a lower level in the tree structure, parameters or a mixture of both.

The keys can be used as above to select a parameter. A parameter has a selection, (ie: TRUE / FALSE), or a value displayed below the parameter name.

HINT: Remember that because the Menu and Parameter lists are looped, the UP key can quickly move you to the last Menu or Parameter in the loop. The keys will repeat if you hold them down. This is an easy way to step through and view a menu's contents.

CHANGING A PARAMETER VALUE

With the parameter you want to change selected, press the center OK key to change to Edit mode. In this mode the arrow keys now perform different functions.

- Change a selection, (i.e. TRUE / FALSE) using the UP and DOWN keys.
- Change a value as follows:
 - The UP and DOWN keys increment / decrement the selected digit.
 - The LEFT and RIGHT keys move the digit selection.
 - The selected digit is indicated by the cursor.

The UP and DOWN keys will repeat if you hold them down.

When changing a value, if the abort icon () is shown over Soft Key 1, pressing this key will abort the edit, leaving the value unchanged. To accept the edited value, press the center OK key.

Trips and other Information displays

An information message will be displayed when the unit is tripped. To clear the message from the display, press Soft key 1.

To reset the trip, allowing the drive to respond to a start command, press the STOP key. See Chapter 10 Trips & Fault Finding.

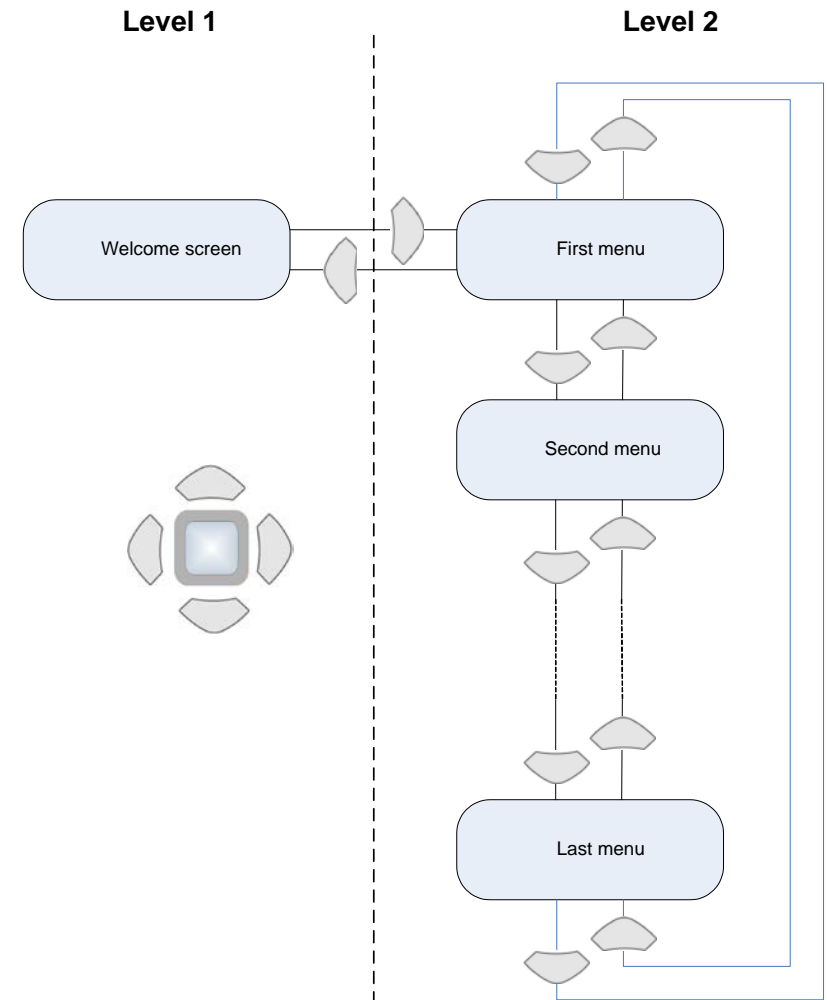

Chapter 8: Menu Organisation

Menu Map

The Menu System consists of a series of menus and sub-menus organised into a “tree” structure. Navigate around the tree on the GKP using the UP, DOWN, LEFT and RIGHT keys. Individual parameters may be present in the menu tree at more than one location. Parameters and/or menus that are not required are automatically hidden on the GKP and web page.

MENU MAP SUMMARY

- Control Screen
- Favourites
- Update Firmware
- Setup
- Advanced Setup
 - Application
 - Motor Control
 - Control & Type
 - Motor Nameplate
 - Induction Motor Data
 - Motor Data PMAC
 - Autotune
 - IO
 - Communications
 - Base Ethernet
 - Base Modbus
 - Option
 - Environment
- Monitor
- Advanced Monitor
 - Trips
 - Application
 - Motor & Drive
 - Inputs and Outputs
 - Communications
 - Base Ethernet
 - Base Modbus
 - Option
 - Energy Meter
- Parameters

* The “Parameters” menu is intended for expert use only, see Appendix D

8-2 Menu Organisation

Menu Descriptions

CONTROL SCREEN

In local sequencing mode the Control Screen menu shows the Local Setpoint, matching speed feedback and configuration of the action of the Run key and direction. When the AC30V is not in local sequencing mode this menu shows the operating speed.



FAVOURITES

The Favourites menu contains up to 20 parameters selected for ease of access.

To add a parameter to the Favourites menu

Using the GKP navigate to the parameter of interest.
Press and hold the OK key until the Attributes screen is shown, (hold for about 2s)
then this appears  + and press the "Add to Favourites" soft key.

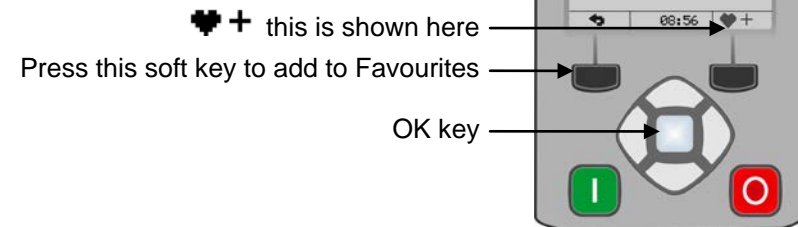

To remove a parameter from the Favourites menu

Using the GKP navigate to the parameter of interest in the Favourites menu. Press and hold the OK key until the Attributes screen is shown, (hold for about 2s).
Press the "Remove from Favourites" soft key,  - .

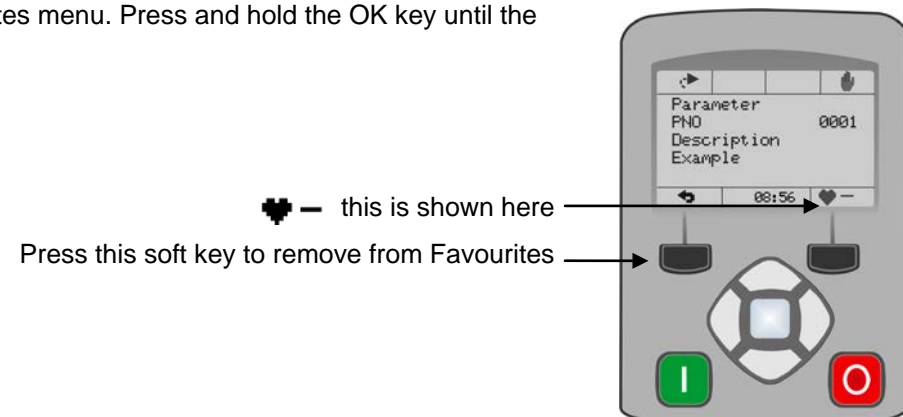

UPDATE FIRMWARE

This menu is shown when a firmware upgrade is available on the inserted SD card.

SETUP

The minimum set of parameters to enable drive configuration when in OPERATOR view level.

ADVANCED SETUP

Additional parameters that may require modification once the Setup Wizard is complete.

This menu is hidden when in OPERATOR view level.

MONITOR

This menu contains those parameters commonly used to verify the correct operation of the drive and the process.

ADVANCED MONITOR

Additional parameters that may be required to configure the AC30V to more specialised applications.

This menu is hidden when in OPERATOR view level.

PARAMETERS

A complete collection of all the parameters in the AC30V. This menu is intended for expert use.

8-4 Menu Organisation

Parameter Map

The following table shows the parameters as they appear in order on the Web page and GKP. Also shown is the Parameter Number, PNO. This is a unique reference for each parameter. For more details about each parameter refer to Appendix D.

<ul style="list-style-type: none"> <ul style="list-style-type: none"> Control Screen <ul style="list-style-type: none"> Local Reference 592 Actual Speed Percent 395 Local Direction 1240 Run Key Action 1140 Favourites Update Firmware <ul style="list-style-type: none"> Update Firmware 1002 Setup <ul style="list-style-type: none"> View Level 1141 Run Setup? 1006 Advanced Setup <ul style="list-style-type: none"> Application Motor Control <ul style="list-style-type: none"> Control & Type <ul style="list-style-type: none"> Motor Type 511 Control Strategy 512 100% Speed in RPM 464 Decel Time 487 Accel Time 486 Current Limit 305 Main Torque Lim 417 Seq Stop Method SVC 1257 Seq Stop Method VHz 484 Stop Mode Ramp Time 504 VHz Shape 422 Fixed Boost 447 Duty Selection 390 Motor Nameplate <ul style="list-style-type: none"> Base Frequency 457 Rated Motor Current 455 Motor Poles 458 Base Voltage 456 Nameplate Speed 459 Power Factor 461 Motor Power 460 	<ul style="list-style-type: none"> <ul style="list-style-type: none"> Induction Motor Data <ul style="list-style-type: none"> Magnetising Current 568 Rotor Time Constant 569 Stator Resistance 571 Leakage Inductance 570 Mutual Inductance 572 Motor Data PMAC <ul style="list-style-type: none"> PM Max Speed 555 PM Max Current 556 PM Rated Current 557 PM Rated Torque 558 PM Motor Poles 559 PM Back EMF KE 560 PM Winding Res 561 PM Winding Induc 562 PM Torque Const KT 563 PM Motor Inertia 564 PM Therm Time Cnst 565 Autotune <ul style="list-style-type: none"> Autotune Enable 255 Autotune Mode 256 Autotune Test Disable 257 Autotune Ramp Time 274
	<ul style="list-style-type: none"> IO <ul style="list-style-type: none"> Anin 01 Type 1 Anin 02 Type 2 Anout 01 Type 3 Anout 02 Type 4 IO Option Type 1178 Thermistor Type 1184 Communications <ul style="list-style-type: none"> Base Ethernet <ul style="list-style-type: none"> DHCP 929 Auto IP 930 User IP Address 933 User Subnet Mask 934 User Gateway Address 935

DHCP To Auto IP	932
Web Access	944
■ Base Modbus	
Maximum Connections	939
High Word First	940
Modbus Timeout	941
Modbus Trip Enable	942
■ Option	
Comms Required	44
BACnet IP Device ID	209
BACnet IP Timeout	210
CANopen Node Address	212
CANopen Baud Rate	213
ControlNet MAC ID	215
DeviceNet MAC ID	219
DeviceNet Baud Rate	220
Modbus Device Address	229
Modbus RTU Baud Rate	230
Parity And Stop Bits	231
High Word First RTU	232
Modbus RTU Timeout	233
High Word First TCP	235
Profibus Node Address	238
Modbus TCP Timeout	236
Address Assignment	199
Fixed IP Address	200
Fixed Subnet Mask	201
Fixed Gateway Address	202
Option Web Enable	203
Web Parameters Enable	204
Option FTP Enable	205
Option FTP Admin Mode	206
IPConfig Enable	207
Comms Trip Enable	48
DNet Producing Inst	222
DNet Consuming Inst	223
CNet Producing Inst	216
CNet Consuming Inst	217
ENet Producing Inst	226
ENet Consuming Inst	227
Read Mapping[16]	55
Write Mapping[16]	120

■ Environment	
Language	1005
View Level	1141
Drive Name	961
GKP Password	1142
Web Access	944
RTC Time to Set	462
Set RTC	463
Display Timeout	983
Startup Page	982
■ Monitor	
Energy kWhr	383
Actual Speed RPM	393
Actual Speed Percent	395
First Trip	696
Recent Trips[10]	895
IP Address	926
■ Advanced Monitor	
■ Trips	
First Trip	696
Active 1 - 32	763
Warnings 1 - 32	829
RTA Code	998
RTA Data	999
■ Application	
■ Motor & Drive	
Actual Speed RPM	393
DC Link Voltage	392
Actual Speed Hz	394
Actual Speed Percent	395
DC Link Volt Filtered	396
Actual Torque	399
Actual Field Current	400
Motor Current Percent	401
Motor Current	402
Motor Terminal Volts	405
Actual Neg Torque Lim	421
Actual Pos Torque Lim	420
Heatsink Temperature	407
CM Temperature	406

Chapter 9: Setup Wizard

GKP Setup Wizard

Purpose of the Setup Wizard

The purpose of the setup wizard is to configure the drive in a clear and concise manner.

First familiarize yourself with Chapter 7 Graphical Keypad, for the keypad functions.

Starting the Setup Wizard

The Setup Wizard is automatically invoked when the drive is reset to factory default settings. The setup wizard may be invoked at any other time by changing the parameter “Run Setup?” to YES (you will find this under the “Setup” menu).

Running the Setup Wizard

At each point in the wizard pressing the OK key selects the displayed value and moves on to the next step.

Pressing **Soft key 1** moves back a step. Pressing the UP and DOWN keys modifies the selected value.

The default setting for all parameters depends on earlier answers and on the physical configuration of the drive so pressing OK repeatedly will result in no parameter values being altered. All data entered is automatically saved without the need for any additional commands.

Setup Wizard Stages

The Setup Wizard is divided into sections. With the exception of the first group of parameters, each section may be skipped. The first group of parameters sets the AC30 operating environment.

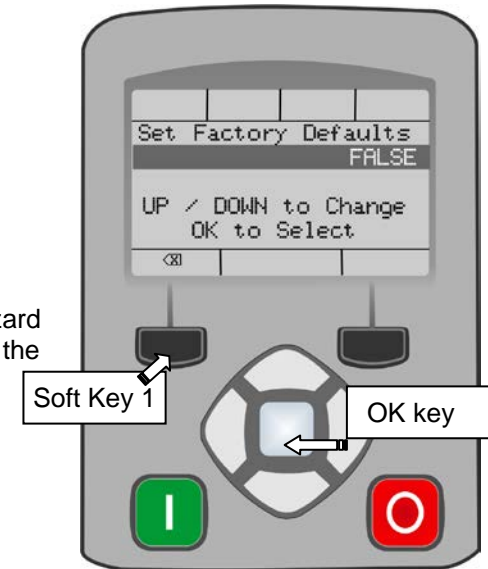

PNO	Parameter	Comment
1000	Set Factory Defaults	Changing this parameter to TRUE then pressing OK resets all parameters back to the default value determined by the AC30V's hardware configuration. If this choice is left FALSE all parameters retain their previously set values.
1005	Language	Select the required language to be used on the GKP. There may be a slight pause while the drive adopts the selected language.
1186	Time and Date	Only shown if an IO option with RTC hardware is fitted.
0944	Web Access	Set to FULL to allow access to parameter values via the web page.
0961	Drive Name	Defaults to show the Ethernet MAC address

9-2 Setup Wizard

Application selection

Selection of the specific Macro and associated parameters.

PNO	Parameter	Validity					Comment
	Setup Application?						Select TRUE to configure the application parameters, FALSE to skip this section
1900	Selected Application	BASIC SPEED CONTROL	AUTO/MANUAL CONTROL	SPEED RAISE/LOWER	SPEED PRESETS	PROCESS PID	
1937	Disable Coast Stop	•	•	•	•	•	
1938	Disable Quickstop	•	•	•	•	•	
1901	RL Ramp Time			•			Sets the rate of change of the output of the Raise/Lower ramp.
1902	RL Reset Value			•			The value of the Raise/Lower ramp output when reset.
1903	RL Maximum Value			•			The upper limit of the Raise/Lower ramp output.
1904	RL Minimum Value			•			The lower limit of the Raise/Lower ramp output
1916	Preset Speed 0				•		The preset speed output when the selected preset is 0.
1917	Preset Speed 1				•		The preset speed output when the selected preset is 1.
1918	Preset Speed 2				•		The preset speed output when the selected preset is 2.
1919	Preset Speed 3				•		The preset speed output when the selected preset is 3.
1920	Preset Speed 4				•		The preset speed output when the selected preset is 4.
1921	Preset Speed 5				•		The preset speed output when the selected preset is 5.
1922	Preset Speed 6				•		The preset speed output when the selected preset is 6.
1923	Preset Speed 7				•		The preset speed output when the selected preset is 7.
1926	PID Setpoint Negate					•	Changes the sign of the setpoint input.
1927	PID Feedback Negate					•	Changes the sign of the feedback input.
1928	PID Prop Gain					•	The proportional gain of the PID controller.
1929	PID Integral TC					•	The integral time constant of the PID controller.
1930	PID Derivative TC					•	The derivative time constant of the PID controller.
1931	PID Output Filter TC					•	The time constant of the first order filter used to filter the PID output.
1932	PID Output Pos Limit					•	The maximum positive excursion, (limit), of the PID controller.
1933	PID Output Neg Limit					•	The maximum negative excursion, (limit), of the PID controller.
1934	PID Output Scaling					•	The overall scaling factor which is applied after the positive and negative limit clamps

Motor Data

Selection of the motor type, control mode and setting the motor control and process control parameters.

PNO	Parameter	Validity			Comment
	Setup Motor?				Select TRUE to configure the motor parameters, FALSE to skip this section
0511	Motor Type	INDUCTION MOTOR		PMAC MOTOR	Selects the motor type.
0512	Control Strategy	VOLTS-HERTZ CONTROL	VECTOR CONTROL		Only visible for induction motor type.
0976	Nominal Supply	•	•	•	Select either 50Hz or 60Hz. Changing this parameter to 60Hz modifies the default values of: <ul style="list-style-type: none"> - Base Frequency - Base Voltage - Nameplate Speed - 100% Speed in RPM.
0457	Base Frequency	•	•		The base frequency on the motor name plate
0456	Base Voltage	•	•		The rated voltage on the motor name plate
0458	Motor Poles	•	•		The number of motor poles. Always enter an even number.
0455	Rated Motor Current	•	•		Current rating from the motor name plate.
0460	Motor Power	•	•		Power rating from the motor name plate.
0459	Nameplate Speed	•	•		Nominal speed from the motor name plate.
0461	Power Factor	•			Power factor from the motor name plate, (often shown as ϕ). If this is not available then leave this at the default value.
0555	PMAC Max Speed			•	The motor's maximum speed.
0556	PMAC Max Current			•	The motor's maximum current
0557	PMAC Rated Current			•	The motor's rated current.
0558	PMAC Rated Torque			•	The motor's rated torque
0559	PMAC Motor Poles			•	The number of motor poles. Always enter an even number.
0560	PMAC Back EMF Const KE			•	The motor's Back EMF line to line, rms value (Ke, Volts rms per 1000 rpm)
0561	PMAC Winding Resistance			•	The motor's resistance, line to line at 25 °C.
0562	PMAC Winding Inductance			•	The motor's inductance line to line at maximum current
0563	PMAC Torque Const KT			•	Torque constant (Kt, Nm/A rms).

9-4 Setup Wizard

PNO	Parameter	Validity		Comment
0564	PMAC Motor Inertia			• The motor's inertia
0565	PMAC Therm Time Const			• The motor's thermal time constant
0478	PMAC SVC Start Cur			• The current level during the startup procedure.
0479	PMAC SVC Start Speed			• The speed setpoint at which the speed control is switched from an open loop mode to a closed loop mode during the startup procedure
0464	100% Speed in RPM	•	•	• Maximum speed in RPM.
0486	Acceleration Time	•	•	• The time that the Drive will take to ramp the setpoint from 0.00% to 100.00% when Ramp Type is LINEAR.
0487	Deceleration Time	•	•	• The time that the Drive will take to ramp the setpoint from 100.00% to 0.00% when Ramp Type is LINEAR.
1257	Seq Stop Method VHz	•		Selects stopping mode that the controller will use once the run command has been removed when in Volts/Hertz control mode, (induction motor only).
0484	Seq Stop Method SVC		•	• Selects stopping mode that the controller will use once the run command has been removed when in Sensorless Vector control mode.
0422	VHz Shape	•		Selects the Volts to Frequency curve.
0390	Duty Selection	•	•	• Selects the drive rating. Affects the ratio of nominal current compared with maximum overload current.

Analog Input and Output

Configuration of the ranges for the analog inputs and outputs. Also selects the thermistor type if an IO option is fitted.

PNO	Parameter	Comment
	Setup Input/Output?	Select TRUE to configure the analog input and output ranges. Set to FALSE to skip this section
0001	Anin 01 Type	Select the hardware range for analog input 1
0002	Anin 02 Type	Select the hardware range for analog input 2
0003	Anout 01 Type	Select the hardware range for analog output 1
0004	Anout 02 Type	Select the hardware range for analog output 2
1184	Thermistor Type	Only shown if an IO option is fitted. If no thermistor is fitted then select NTC to avoid a MOTOR OVERTEMP Trip

Fieldbus Options

This section is only shown if a communications option is fitted.

PNO	Parameter	Comment
0044	Comms Required	This defaults to match the communications option that is fitted. If no option is required select NONE. Selecting a different option will result in a configuration error.

These parameters are shown when the CANopen option is fitted.

PNO	Parameter		Comment
0044	Comms Required	CANOPEN	<i>Refer to CANopen Technical Manual HA501841U001</i>
0212	CANopen Node Address	•	
0213	CANopen Baud Rate	•	
0048	Comms Trip Enable	•	

These parameters are shown when the DeviceNet option is fitted.

PNO	Parameter		Comment
0044	Comms Required	DEVICENET	<i>Refer to DeviceNet Technical Manual HA501840U001</i>
0219	DeviceNet MAC ID	•	
0220	DeviceNet Baud Rate	•	
0048	Comms Trip Enable	•	

These parameters are shown when the Ethernet IP option is fitted.

PNO	Parameter		Comment
0044	Comms Required	ETHERNET IP	<i>Refer to EtherNet IP Technical Manual HA501842U001</i>
0199	Address Assignment	•	
0200	Fixed IP Address	•	
0201	Fixed Subnet Mask	•	
0202	Fixed Gateway Address	•	
0203	Option Web Enable	•	
0048	Comms Trip Enable	•	

These parameters are shown when the Modbus RTU option is fitted.

PNO	Parameter		Comment
0044	Comms Required	MODBUS RTU	<i>Refer to Modbus RTU Technical Manual HA501839U001</i>
0229	Modbus Device Address	•	
0230	Modbus RTU Baud Rate	•	
0231	Parity And Stop Bits	•	
0232	High Word First RTU	•	
0233	Modbus RTU Timeout	•	
0048	Comms Trip Enable	•	

9-6 Setup Wizard

These parameters are shown when the Profibus DPV1 option is fitted.

PNO	Parameter		Comment
0044	Comms Required	PROFIBUS DPV1	Refer to Profibus DP-V1 Technical Manual HA501837U001
0238	Profibus Node Address	•	
0048	Comms Trip Enable	•	

These parameters are shown when the Profinet IO option is fitted.

PNO	Parameter		Comment
0044	Comms Required	PROFINET IO	Refer to Profinet IO Technical Manual HA501838U001
0199	Address Assignment	•	
0200	Fixed IP Address	•	
0201	Fixed Subnet Mask	•	
0202	Fixed Gateway Address	•	
0203	Option Web Enable	•	
0048	Comms Trip Enable	•	

On-board Ethernet

Configuration of the on board Ethernet option.

PNO	Parameter	Comment
	Setup Base Ethernet	Select TRUE to configure the on board Ethernet port. Select FALSE to skip this section
0929	DHCP	
0930	Auto IP	
0933	User IP Address	Only visible if DHCP and Auto IP are both FALSE.
0934	User Subnet Mask	Only visible if DHCP and Auto IP are both FALSE.
0935	User Gateway Address	Only visible if DHCP and Auto IP are both FALSE.
	Setup Base Modbus	Select TRUE to configure the on board Ethernet port to also act as a Modbus IP client. Select FALSE to skip the following parameters
0939	Maximum Connections	Sets the maximum number of Modbus clients allowed. If set to zero, then no connections will be allowed.
0942	Modbus Trip Enable	Set TRUE to enable the Modbus Trip. The parameter Modbus Timeout must be set to a value other than zero
0940	High Word First	If set to TRUE, the most significant word of a 32-bit parameter will be mapped to the first register, and the least significant word to the next register.
0941	Modbus Timeout	Sets the process active timeout

Autotune Parameters

Autotune enable and autotune mode. To run the autotune process, complete the wizard then run the drive.

PNO	Parameter	Comment
0255	Autotune Enable	Select TRUE to enable a motor autotune next time the motor is started. (Only visible for induction motor sensorless vector control mode).

Finalising Setup

Once the Setup Wizard has been run to completion the feature is automatically disabled. Re-starting the drive will not cause the Setup Wizard to be run again. (If it is desired to re-run the Setup Wizard, this can be achieved as detailed above in “Starting the Setup Wizard”).

Parker Drive Quicktool (PDQ) PC Software

INSTALLATION

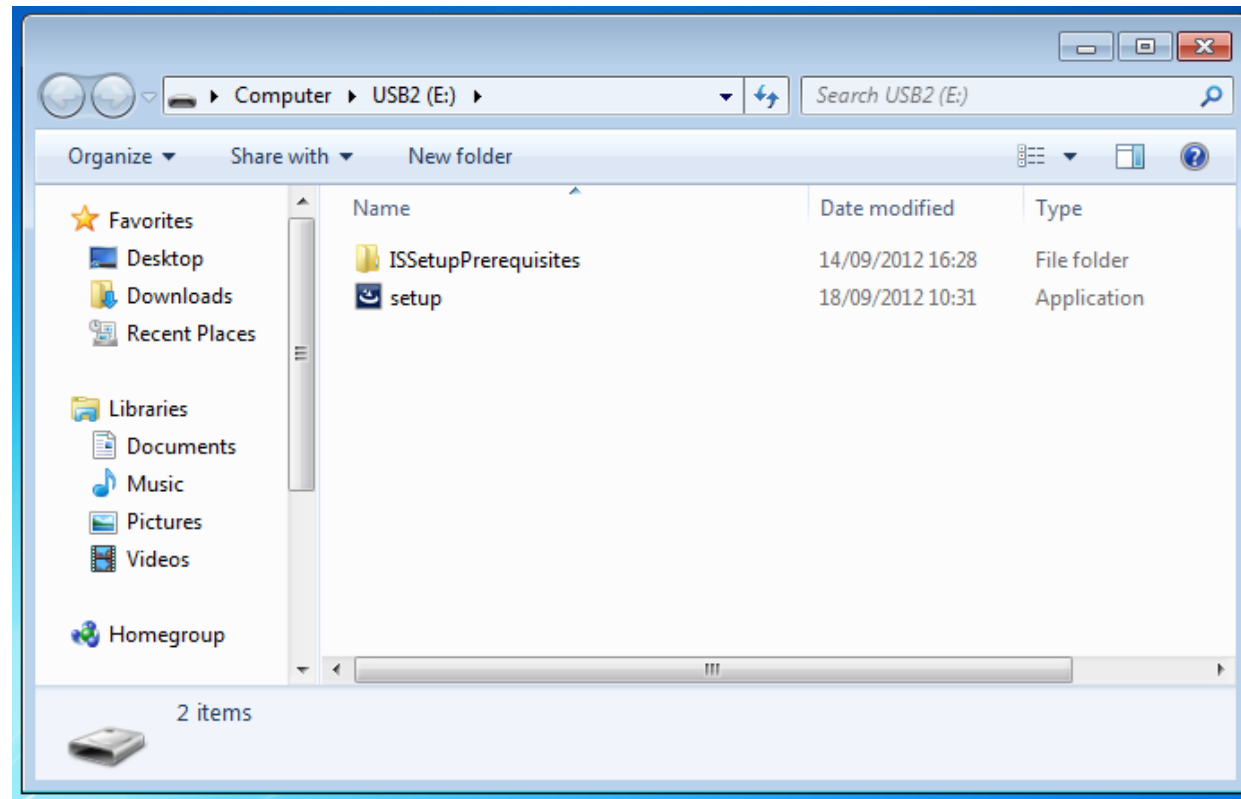

Figure 9-1 Install application

9-8 Setup Wizard

Launch the installer, setup.exe, from the provided CD or download the latest version from www.parker.com/ssd/pdq

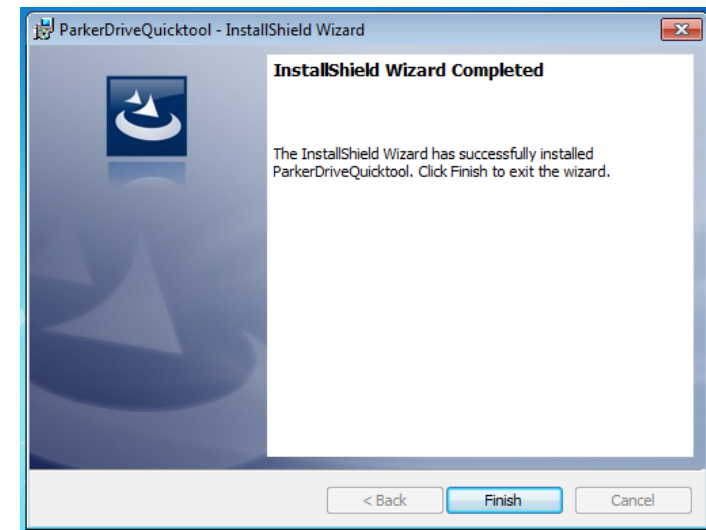
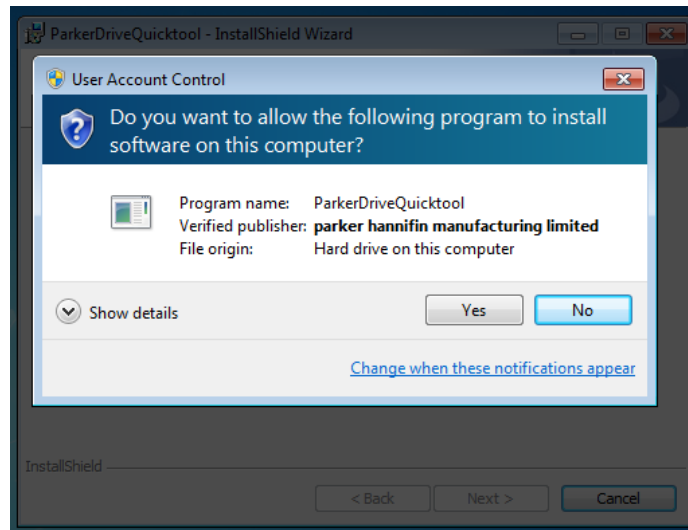
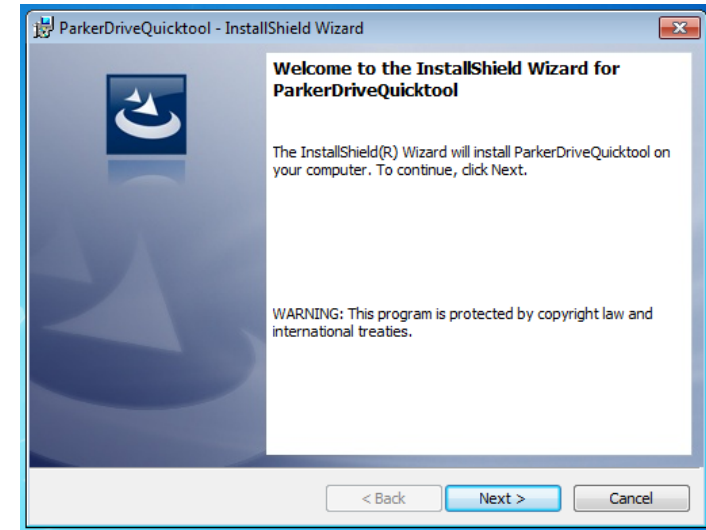

Figure 9-2 InstallShield

Follow the steps of the InstallShield Wizard.

STARTING THE WIZARD

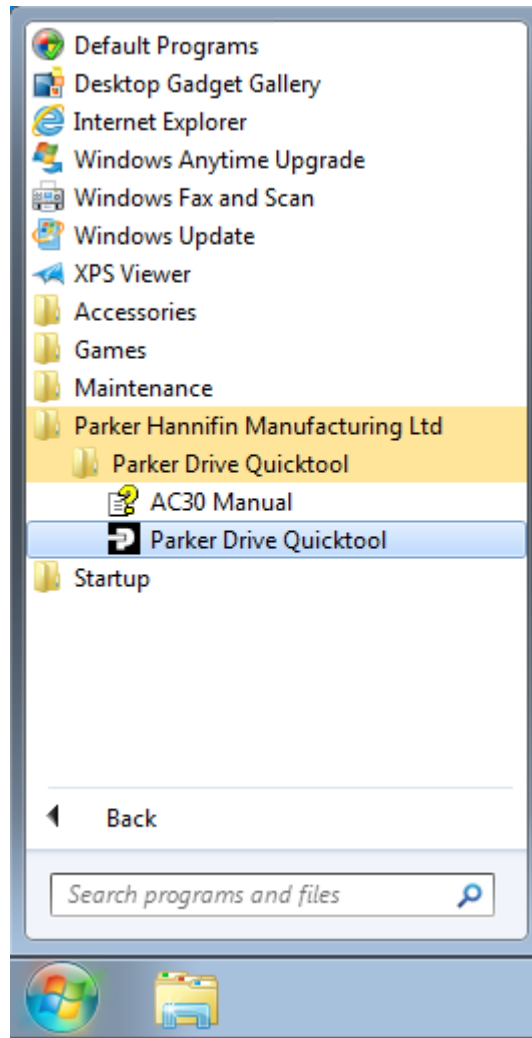

Figure 9-4 Start the Wizard



Figure 9-3 Desktop shortcut

Once the InstallShield completes, run the PDQ from the “Start” menu as shown or from the desktop shortcut as shown in Figure 9-4

9-10 Setup Wizard

TASK SELECTION

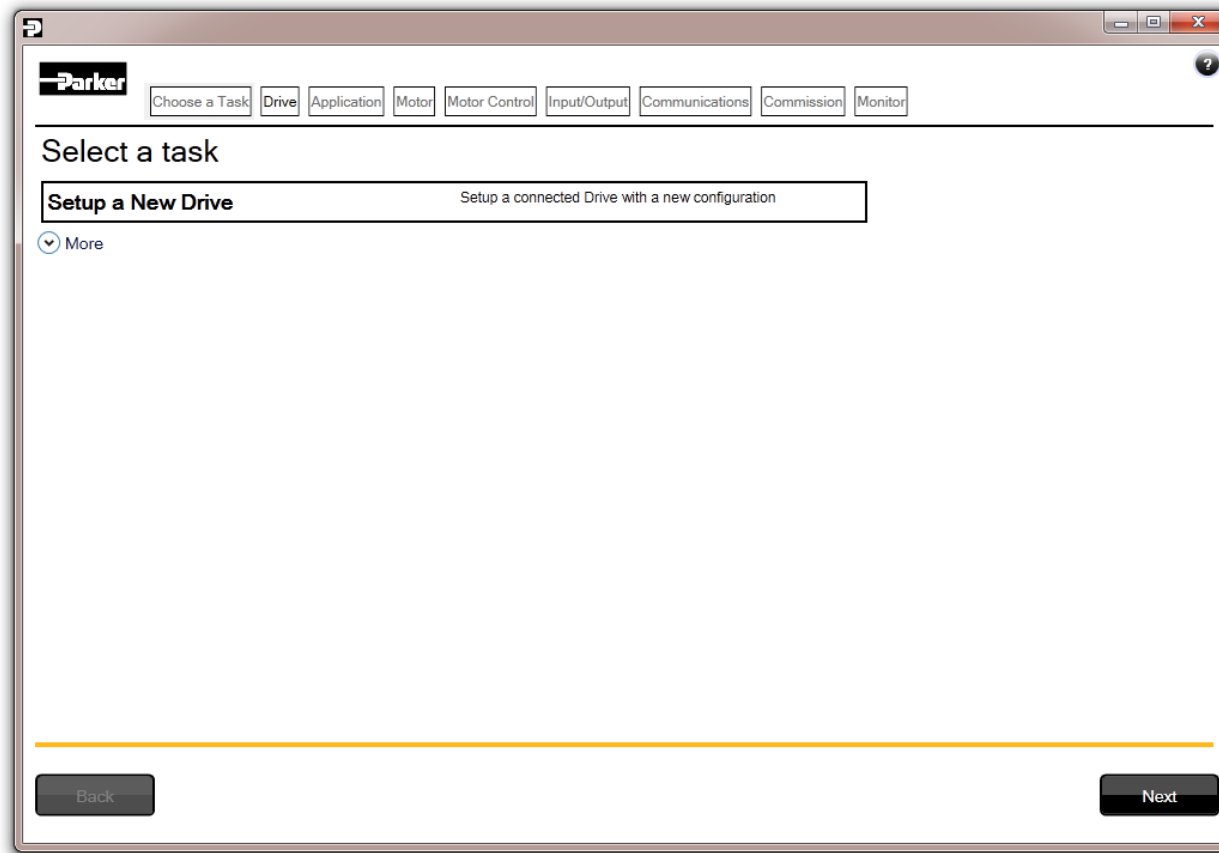

Figure 9-5 Task selection

The first page of the PDQ wizard allows you to choose the task you wish to perform. Figure 9-5 shows the default selection, "Setup a New Drive". To start this wizard task, click on the "Next" button or the "Drive" page in the title bar.

Note: No data or settings will be changed in the Drive until the "Commission" page is reached and download is confirmed by the Engineer.

FIND DRIVE

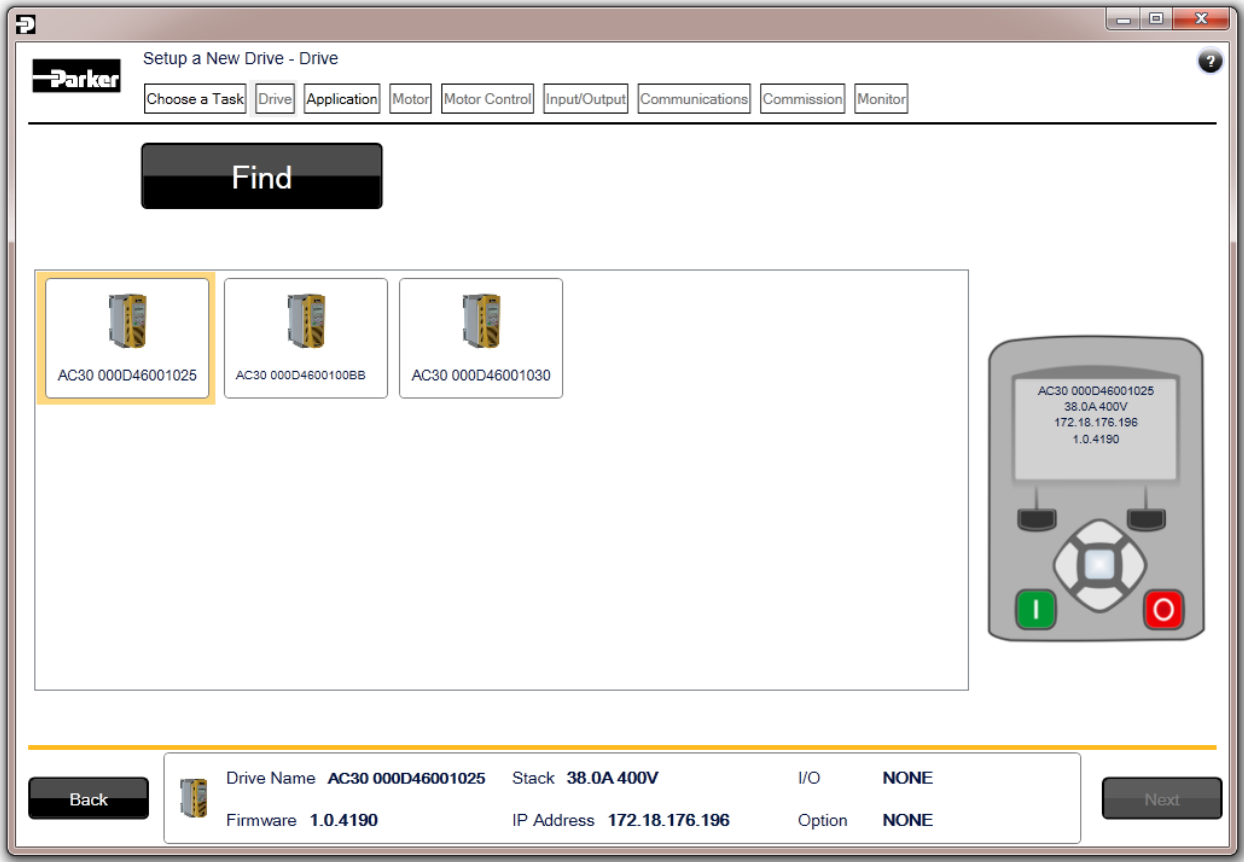

Figure 9-6 Automatic Drive detection

The wizard will automatically detect all AC30V Drives that are visible to the PC via its Ethernet connections. This normally takes 10 seconds, during which time the user interface will go grey and will not respond to you. Once the Drive detection is complete, find your Drive in the list and click on it with the mouse. Information about the selected Drive will be displayed in the status area at the bottom of the screen. Ensure you have selected the correct Drive before continuing. Note: The selected drive's name will match that shown on the GKP home screen.

Click on the "Next" button to begin Commissioning this Drive.

9-12 Setup Wizard

Troubleshooting Drive Detection

Problem	Possible cause	Solution
Drive not found	Drive not connected to the same physical Ethernet network as the PC	Connect Drive and PC to the same network or directly to each other
Drive found but no information displayed	Another person has their PC connected to the Drive	Disconnect the other PC

SELECT MACRO

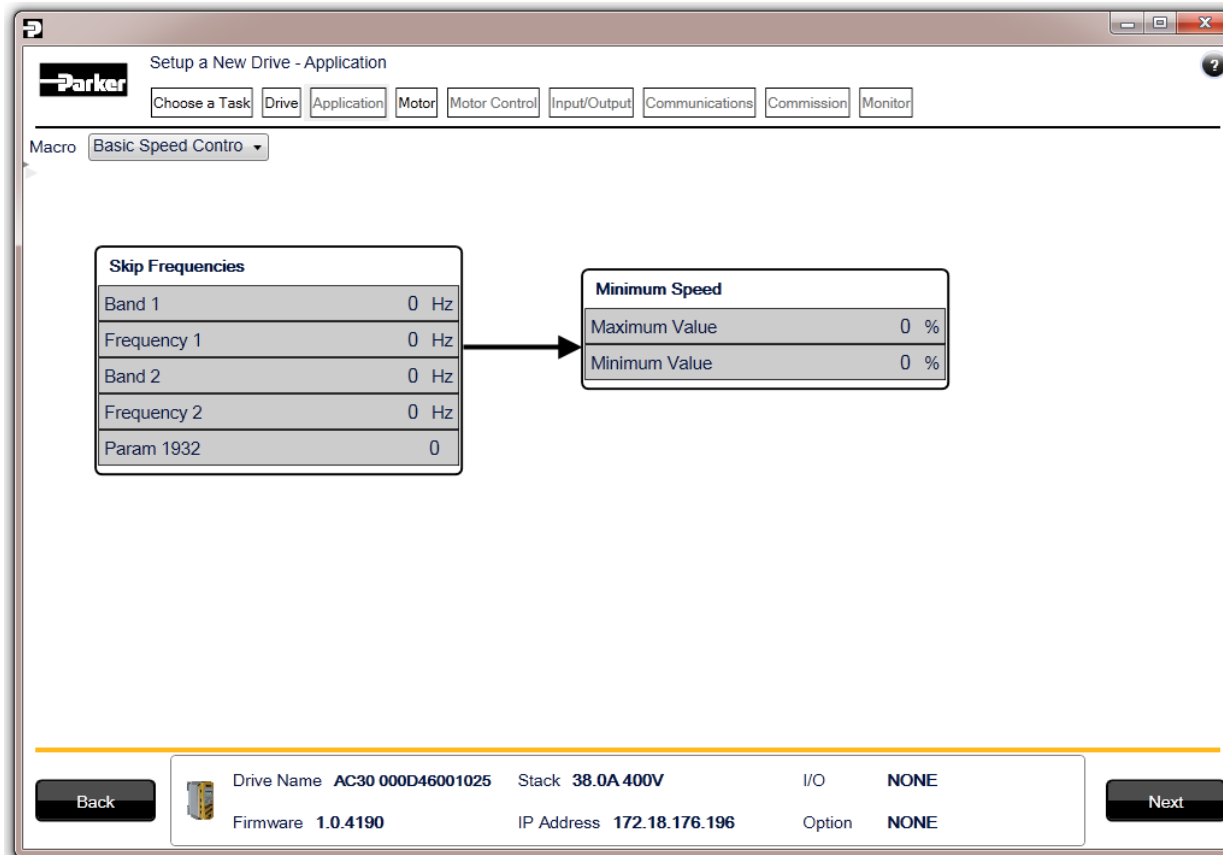

Figure 9-7 Macro selection

Select the desired Application Macro from the drop down list. Adjust any parameters that are needed for your specific application.

SELECT MOTOR

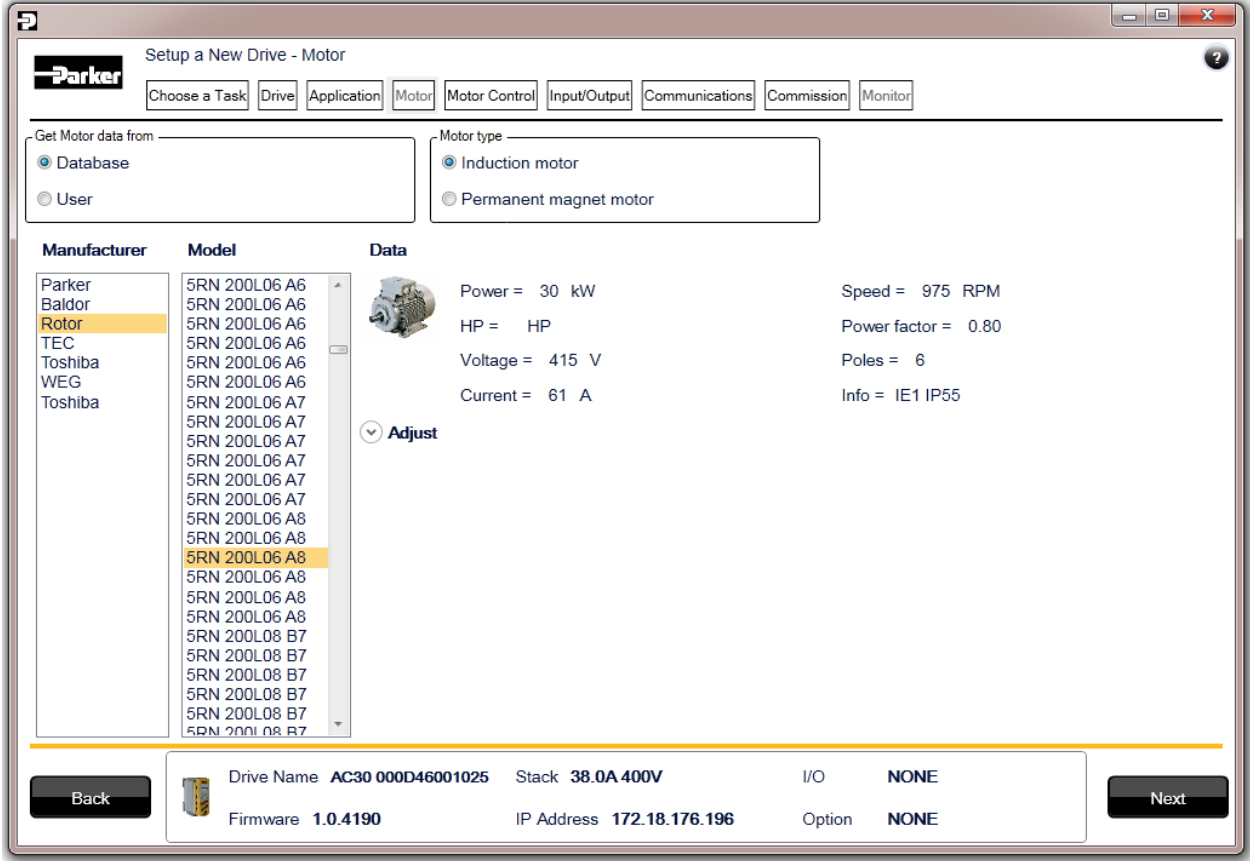

Figure 9-8 Motor selection from database

Motor data may either be selected from the built in motor database or entered by the engineer as a custom motor. The Motor page has two options at the top of the page that need to be selected.

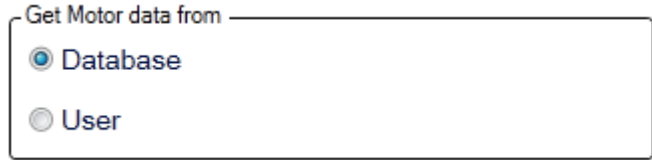
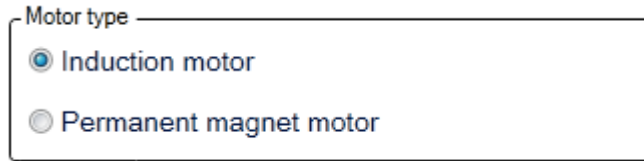

Figure 9-9 Motor data selection

9-14 Setup Wizard

“Database” is selected by default and the screen will show the motor database selector.



Motor type

Induction motor

Permanent magnet motor

Figure 9-10 Motor type selection

“Induction Motor” is selected by default. This selection will filter the motor database to the selected type. It also displays only the appropriate “User” settings if a custom motor is required.

Motor database

At the left hand side is a list of manufacturers whose motors are in the database. Select the appropriate manufacturer from the list. If your motor’s manufacturer is not shown in the list then you will need to provide custom “User” data instead.

Once the manufacturer is selected, the list of motor models will be displayed. The model list is sorted by the manufacturers part number. Select your motor from the list. The motors data and image will then be displayed so you can ensure you have the correct one selected.

Setup a New Drive - Motor

Choose a Task Drive Application Motor Motor Control Input/Output Communications Commission Monitor

Get Motor data from

Database

User

Motor type

Induction motor

Permanent magnet motor

Basic

Rated Motor Current	61	A
Base Voltage	415	V
Base Frequency	50	Hz

Advanced

Motor Poles	6
Nameplate Speed	975 RPM
Motor Power	30 kW
Power Factor	0.8

Back

Drive Name AC30 000D46001025 Stack 38.0A 400V I/O NONE

Firmware 1.0.4190 IP Address 172.18.176.196 Option NONE

Next

Figure 9-11 Custom Motor configuration

Custom Motor

Custom motor data is entered in this page. The page is split into two parts. On the top are “Basic” motor parameters and below are more advanced ones. Nominal defaults will have been set, depending on the size of AC30V Drive being configured. The Engineer should adjust these default values with data from the motor nameplate or technical specification.

9-16 Setup Wizard

SETUP THE DRIVE CONTROL

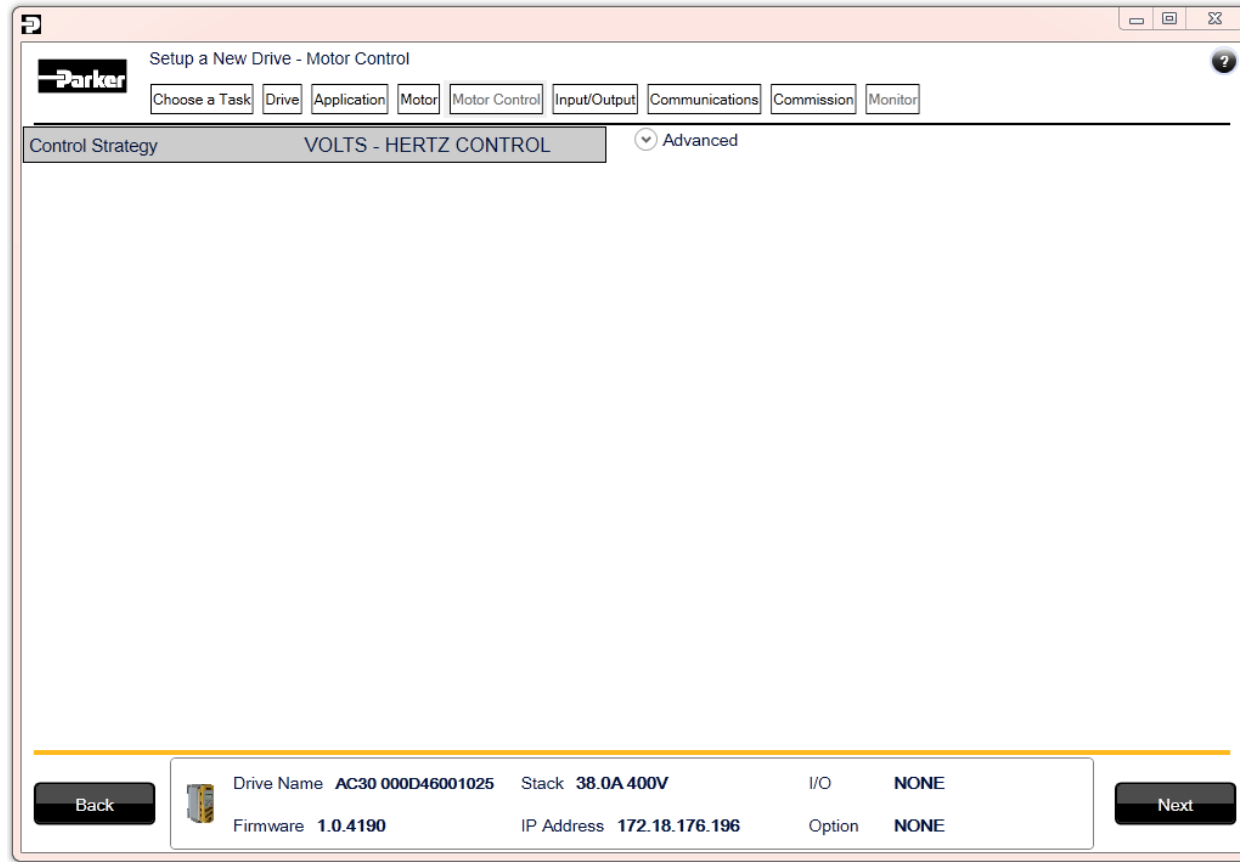

Figure 9-12 Drive Control setup

The “Control” page allows configuration of the Drive control. The basic control parameters are shown on the left hand side. Expand the “Advanced” dropdown to see more advanced parameters. The exact parameters show will depend on the motor type previously selected.

SETUP I/O

Parameter	Value
Anin 01 Type	-10..10V
Anin 02 Type	-10..10V
Anout 01 Type	-10..10V
Anout 02 Type	0..10V

I/O Option

Back	Drive Name AC30 000D46001025 Stack 38.0A 400V I/O NONE	Next
	Firmware 1.0.4190 IP Address 172.18.176.196 Option NONE	

Figure 9-13 Drive I/O setup

On this screen the mode of the programmable I/O can be changed. If an I/O option card is fitted it can be configured in the “I/O Option” drop down.

9-18 Setup Wizard

SETUP COMMUNICATIONS

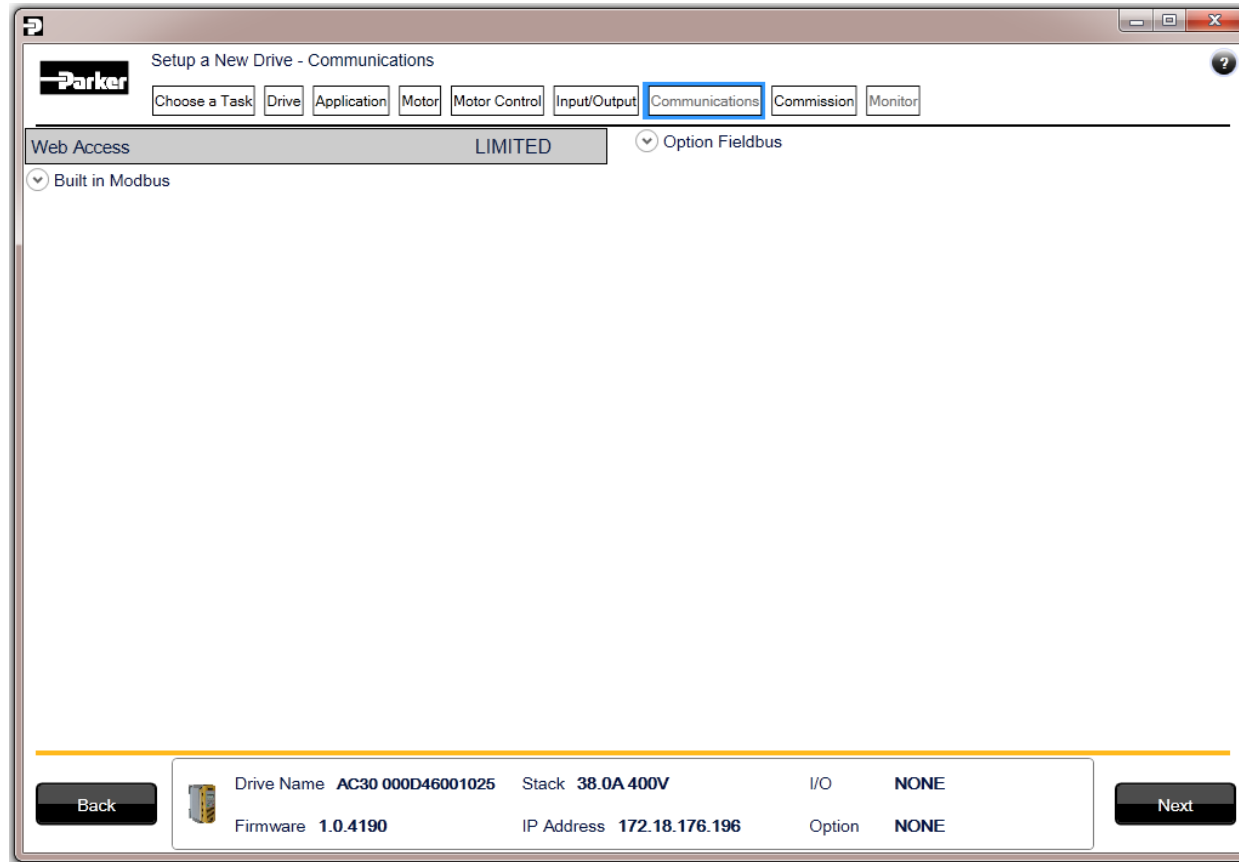

Figure 9-14 Drive Communications setup

The built in web browser can be enabled/disabled from this screen.

If required, the built in Modbus can be setup from, the “Built in Modbus” dropdown.

If an optional Fieldbus is fitted, it can be configured from the “Option Fieldbus” dropdown.

COMMISSION THE DRIVE

Setup a New Drive - Commission

Choose a Task | Drive | Application | Motor | Motor Control | Input/Output | Communications | **Commission** | Monitor

Step 1

Drive Name

Author

Company

Project name

Description

Version

Save CAN EDS file

Step 2

Program Drive

Step 3 (Optional but recommended)

Save

View changes

Back

Drive Name	AC30 000D46001025	Stack	38.0A 400V	I/O	NONE
Firmware	1.0.4190	IP Address	172.18.176.196	Option	NONE

Next

Figure 9-15 Programming the Drive

The “Commission” page is used to commission the Drive with the Selected macro and motor settings chosen during the Wizard. There are three steps that are performed to finalise the Commissioning of the Drive.

1. Enter the Drive’s name in the left of the screen.
2. “Program Drive”. This step writes your settings to the Drive and overwrites any existing configuration in the Drive.
3. “Save”. This is an optional step but highly recommended. You may save all your settings into a “.project” file on your PC for later use.

After these three steps, the Drive is ready to use.

9-20 Setup Wizard

MONITOR THE DRIVE

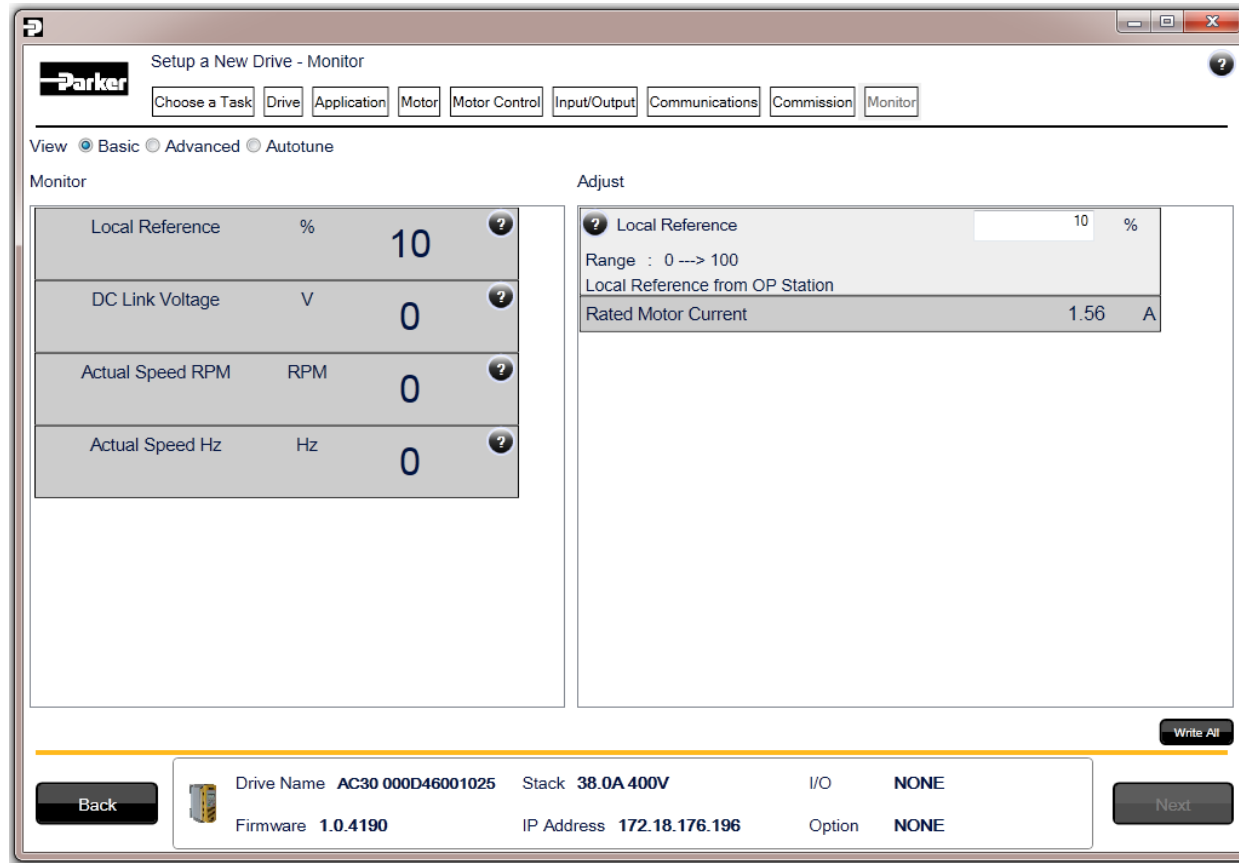

Figure 9-16 Monitor the Drive and fine tune

The final page of the Wizard allows the Engineer to Monitor, Autotune and if necessary fine tune the Drive.

There are three modes of display in the Monitor screen.

1. "Basic". In this view a predefined list of Drive parameters are monitored and adjustment of the most common parameters is enabled. This simple screen should be suitable for most Engineers needs.
2. "Autotune". In this view the Engineer can setup the Drive for Autotuning and monitor it as the autotune runs. As the Autotune can involve rotation of the motor shaft, the Autotune must be started from the local GKP, the Drive cannot be started remotely from the tool.
3. "Advanced". Every parameter of the Drive can be monitored and adjusted in this mode.

Chapter 10: Trips & Fault Finding

Trips and Fault Finding

WHAT HAPPENS WHEN A TRIP OCCURS

When a trip occurs, the drive's power stage is immediately disabled causing the motor and load to coast to a stop. The trip is latched until action is taken to reset it. This ensures that trips due to transient conditions are captured and the drive is disabled, even when the original cause of the trip is no longer present.

Keypad Indications

If a trip condition is detected the activated alarm is displayed on the GKP display.

RESETTING A TRIP CONDITION

All trips must be reset before the drive can be re-enabled. A trip can only be reset once the trip condition is no longer active, i.e. a trip due to a heatsink over-temperature will not reset until the temperature is below the trip level.

You can reset the trip as follows:

1. Press the  (STOP) key to reset the trip and clear the alarm from the display.
2. In remote terminal sequencing mode, create a 0 to 1 transition on the RESET TRIP bit, (bit 7), in the App Control Word parameter.
3. In remote communications sequencing mode, create a 0 to 1 transition on the RESET TRIP bit, (bit 7), in the Comms Control Word parameter.

10-2 Trips & Fault Finding

USING THE KEYPAD TO MANAGE TRIPS

Trip Messages

If the drive trips, then the display immediately shows a message indicating the reason for the trip. The possible trip messages are given in the table below.

ID	Trip Name	Possible Reason for Trip
1	OVER VOLTAGE	<i>The drive internal dc link voltage is too high:</i> <ul style="list-style-type: none">• The supply voltage is too high• Trying to decelerate a large inertia load too quickly; DECEL TIME time too short• The brake resistor is open circuit
2	UNDER VOLTAGE	<i>DC link low trip:</i> <ul style="list-style-type: none">• Supply is too low/power down
3	OVER CURRENT	<i>The motor current being drawn from the drive is too high:</i> <ul style="list-style-type: none">• Trying to accelerate a large inertia load too quickly; ACCEL TIME time too short• Trying to decelerate a large inertia load too quickly; DECEL TIME time too short• Application of shock load to motor• Short circuit between motor phases• Short circuit between motor phase and earth• Motor output cables too long or too many parallel motors connected to the drive• FIXED BOOST level set too high
4	STACK FAULT	<i>Stack self protection</i> <ul style="list-style-type: none">• Instantaneous overcurrent detected by the power stack. Refer to OVERCURRENT in this table.• Instantaneous over voltage event. Refer to OVER VOLTAGE in this table
5	STACK OVER CURRENT	<i>The motor current exceeded the capabilities of the power stack.</i> <ul style="list-style-type: none">• Instantaneous overcurrent detected by the power stack. Refer to OVERCURRENT in this table.
6	CURRENT LIMIT	V/Hz mode only: If the current exceeds 200% of stack rated current for a period of 1 second, the drive will trip. This is caused by shock loads
7	MOTOR STALL	<i>The motor has stalled (not rotating) Drive in current limit >200 seconds:</i> <ul style="list-style-type: none">• Motor loading too great• FIXED BOOST level set too high
8	INVERSE TIME	<i>A prolonged overload condition, exceeding the Inverse Time allowance, has caused the trip:</i> <ul style="list-style-type: none">• Remove the overload condition

ID	Trip Name	Possible Reason for Trip
9	MOTOR I2T	Only for PMAC Motor: A prolonged load condition, exceeding the motor rated current, has caused the trip. The estimated motor load has reached a value of 105%
10	LOW SPEED I	<i>The motor is drawing too much current (> 100%) at zero output frequency:</i> <ul style="list-style-type: none"> • FIXED BOOST level set too high
11	HEATSINK OVERTEMP	<i>Drive heatsink temperature too high</i> <ul style="list-style-type: none"> • The ambient air temperature is too high • Poor ventilation or spacing between drives • Check heatsink fan is rotating
12	AMBIENT OVERTEMP	<i>Processor temperature too high</i> <ul style="list-style-type: none"> • The ambient temperature in the drive is too high
13	MOTOR OVERTEMP	<i>The motor temperature is too high, (required IO Option card)</i> <ul style="list-style-type: none"> • Excessive load • Motor voltage rating incorrect • FIXED BOOST level set too high • Prolonged operation of the motor at low speed without forced cooling • Break in motor thermistor connection
14	EXTERNAL TRIP	<i>The external trip input is high:</i> <ul style="list-style-type: none"> • Check configuration to identify the source of the signal (non-standard configuration)
15	BRAKE SHORT CCT	<i>External dynamic brake resistor has been overloaded:</i> <ul style="list-style-type: none"> • The external dynamic brake has developed a short circuit. • Wiring fault
16	BRAKE RESISTOR	<i>External dynamic brake resistor has been overloaded:</i> <ul style="list-style-type: none"> • Trying to decelerate a large inertia too quickly or too often
17	BRAKE SWITCH	<i>Internal dynamic braking switch has been overloaded:</i> <ul style="list-style-type: none"> • Trying to decelerate a large inertia too quickly or too often
18	LOCAL CONTROL	<i>Keypad has been disconnected from drive whilst drive is running in Local Control:</i> <ul style="list-style-type: none"> • GKP accidentally disconnected from drive
19	COMMS BREAK	<i>Lost option communications:</i> <ul style="list-style-type: none"> • A break in option communications has been detected. Refer to option communications manual.

10-4 Trips & Fault Finding

ID	Trip Name	Possible Reason for Trip
20	LINE CONTACTOR	<p><i>DC Link failed to reach the undervoltage trip level within the contactor feedback time.</i></p> <ul style="list-style-type: none"> • The Line contactor failed to connect. • Missing 3-phase line supply
21	PHASE FAIL	<ul style="list-style-type: none"> • Not yet implemented (reserved for large frame)
22	VDC RIPPLE	<p><i>The DC link ripple voltage is too high:</i></p> <ul style="list-style-type: none"> • Check for a missing input phase • Repetitive start / stop or forward reverse action.
23	BASE MODBUS BREAK	<p><i>Lost Base Modbus communications:</i></p> <ul style="list-style-type: none"> • A break in the Base Modbus communications has been detected. Refer to "Appendix A Modbus TCP".
24	24V OVERLOAD	<p><i>24V rail is low</i></p> <ul style="list-style-type: none"> • Output overload due to excess current being drawn from the 24v terminal.
25	PMAC SPEED ERROR	<p><i>Only for PMAC motor : When using the Start feature in Sensorless Vector Control, the real speed hasn't reached the speed setpoint after 5 seconds to move from open to closed loop control or to move from closed to open loop</i></p>
26	OVERSPEED	<p><i>Overspeed:</i></p> <ul style="list-style-type: none"> • > 150% base speed when in Sensorless Vector mode
27	SAFE TORQUE OFF	<p><i>Attempt to start the motor with the Safe Torque Off active</i></p> <ul style="list-style-type: none"> • Check the STO wiring. It will usually be necessary to power the drive off and on to completely clear this event.

HEXADECIMAL REPRESENTATION OF TRIPS

Each trip has a unique, eight-digit hexadecimal number as shown in the tables below. This number is referred to as the trip mask. The trip masks are used in the Enable, Active and Warnings parameters in the Trips module.

ID	Trip Name	Mask	User Disable
1	OVER VOLTAGE	00000001	
2	UNDER VOLTAGE	00000002	
3	OVER CURRENT	00000004	
4	STACK FAULT	00000008	
5	STACK OVER CURRENT	00000010	
6	CURRENT LIMIT	00000020	✓
7	MOTOR STALL	00000040	✓
8	INVERSE TIME	00000080	✓
9	MOTOR I2T	00000100	✓
10	LOW SPEED I	00000200	✓
11	HEATSINK OVERTEMP	00000400	
12	AMBIENT OVERTEMP	00000800	✓
13	MOTOR OVERTEMP	00001000	✓
14	EXTERNAL TRIP	00002000	✓
15	BRAKE SHORT CCT	00004000	✓

ID	Trip Name	Mask	User Disable
16	BRAKE RESISTOR	00008000	✓
17	BRAKE SWITCH	00010000	✓
18	LOCAL CONTROL	00020000	✓
19	COMMS BREAK	00040000	✓
20	LINE CONTACTOR	00080000	✓
21	PHASE FAIL	00100000	✓
22	VDC RIPPLE	00200000	✓
23	BASE MODBUS BREAK	00400000	✓
24	24V OVERLOAD	00800000	✓
25	PMAC SPEED ERROR	01000000	✓
26	OVERSPEED	02000000	✓
27	SAFE TORQUE OFF	04000000	

10-6 Trips & Fault Finding

Runtime Alerts

A Runtime Alert is a fault that indicates a permanent hardware error. The Runtime Alert display is of the form

```
RUNTIME ALERT
CODE 00000000
```

CODE is a number in the range 0 to 65000. The following value is used to provide additional information to assist Parker Hannifin Technical Support personnel.

CODE	ERROR	Possible Reason for Error
1 to 255	Internal exception	<ul style="list-style-type: none">• VCM not secured to power stack• Option not secured correctly to VCM control card• Earth bonding failure.• Fault during firmware upgrade
1001 to 1003	Processor overload	<ul style="list-style-type: none">• Select a lower switching frequency, (Parameters::Motor Control::Pattern Generator::Stack Frequency)• Record the error message and contact Technical Support
1006	Memory overflow	<ul style="list-style-type: none">• Reduce the complexity of the application• Reduce the number of parameters being accessed via the on board Modbus TCP protocol• Reduce the number of parameters being accessed by the fieldbus communications option.
1007	Uninitialized pointer	<ul style="list-style-type: none">• Record the error message and contact Technical Support
1010, 1101 to 1111	Initialization error	<ul style="list-style-type: none">• Record the error message and contact Technical Support
1200 to 1299	Communications option error	<ul style="list-style-type: none">• Ensure the communications option is correctly fitted• Update the firmware in the AC30.• Replace the communications option
1300	Ethernet fault	<ul style="list-style-type: none">• Record the error message and contact Technical Support
1301	Modbus server	<ul style="list-style-type: none">• Record the error message and contact Technical Support
1302	HTTP server fault	<ul style="list-style-type: none">• Record the error message and contact Technical Support

CODE	ERROR	Possible Reason for Error
1303	DCT server fault	<ul style="list-style-type: none"> Record the error message and contact Technical Support
1401 1402	Control Module test	<ul style="list-style-type: none"> Control module self-test error
1403 1404	Power stack test	<ul style="list-style-type: none"> VCM not secured to power stack Power stack self-test error
1501 1502 1503	IO Option identity IO Option processor Unknown IO Option	<ul style="list-style-type: none"> Ensure the IO option is correctly fitted Update the firmware in the AC30. Replace the IO option
1502	IO Option processor	<ul style="list-style-type: none"> Ensure the IO option is correctly fitted Update the firmware in the AC30. Replace the IO option
1503	Unknown IO Option	<ul style="list-style-type: none"> Ensure the IO option is correctly fitted Update the firmware in the AC30. Replace the IO option
1601	Stack internal fault	<ul style="list-style-type: none"> Return the power stack to Parker Hannifin repair center.

10-8 Trips & Fault Finding

Fault Finding

Problem	Possible Cause	Remedy
Drive will not power-up	Fuse blown	Check supply details, fit correct fuse. Check Product Code against Model No.
	Faulty cabling	Check all connections are correct/secure. Check cable continuity
Drive fuse keeps blowing	Faulty cabling or connections wrong	Check for problem and rectify before replacing with correct fuse
	Faulty drive	Contact Parker
Cannot obtain power-on state	Incorrect or no supply available	Check supply details
Motor will not run at switch-on	Motor jammed	Stop the drive and clear the jam Safe Torque Off circuit active. Check the STO connections then power the drive off and on to clear any latched STO fault.
Motor runs and stops	Motor becomes jammed	Stop the drive and clear the jam
	Open circuit speed reference potentiometer	Check terminal

Chapter 11: Routine Maintenance & Repair

Routine Maintenance

Periodically inspect the drive for build-up of dust or obstructions that may affect ventilation of the unit. Remove this using dry air.

Preventative Maintenance

FAN CASSETTE

The power stack cooling fan is designed to be field replaceable by a competent person. For preventative maintenance replace the fan cassette every 5 years operation, or whenever the drive trips on 'heatsink overtemperature' under normal operation. Spare fan cassettes are available to order from your local Parker sales office.

Fan Cassette Removal Instructions

1. Remove the two retaining screws and lift off fan guard.
2. Lift out the fan(s) and then disconnect wiring before replacing with the new fan(s) assembly
 Frame D - LA501683
 Frame E - LA501684
 Frame F - LA501683

making sure the fan is correct way up.

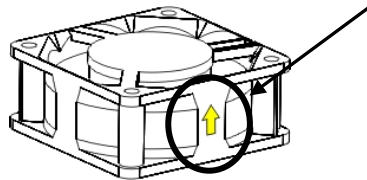

3. Replace the fan guard and tighten the screws to 1.3Nm.

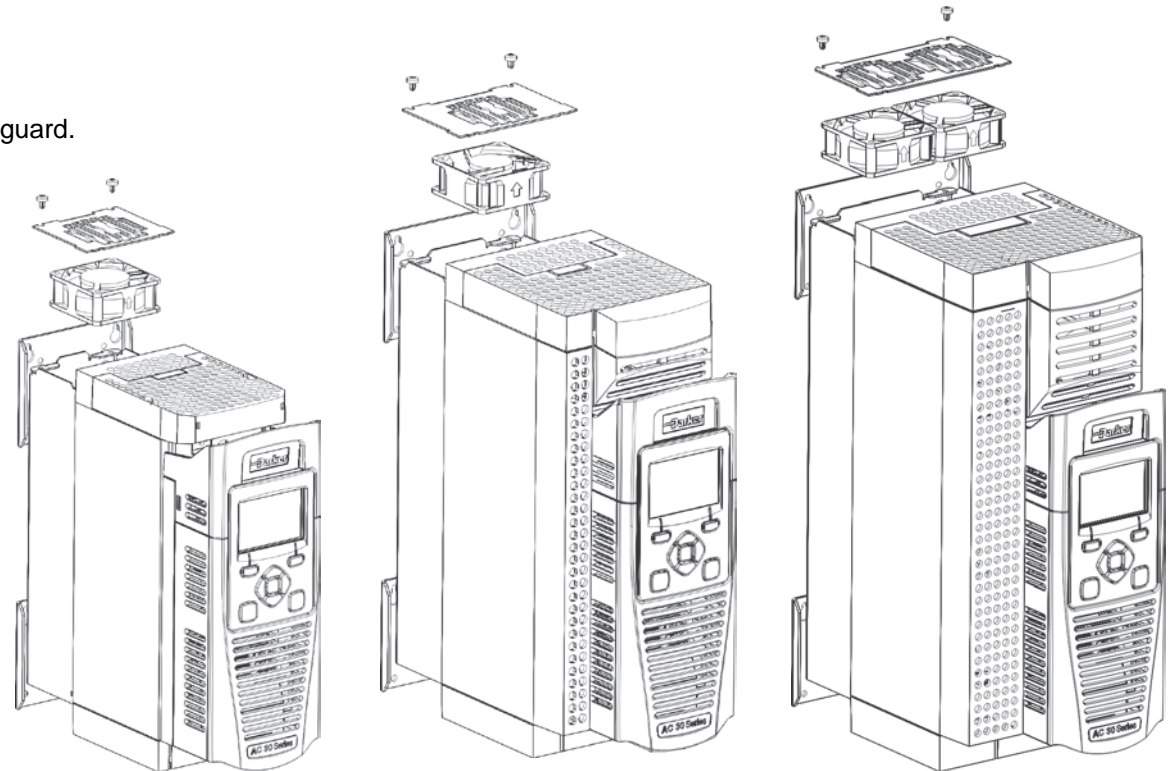

Frame D

Frame E

Frame F

11-2 Routine Maintenance & Repair

DC LINK CAPACITORS

For preventative maintenance the DC link capacitors must be replaced every 10 years operation, or when the drive trips on 'DC link ripple' under normal operating conditions. The unit must be returned to your local Parker sales office for replacement.

Repair

There are no user-serviceable components. Only Parker trained personnel are permitted to repair this product to maintain certifications, reliability and quality levels.

IMPORTANT MAKE NO ATTEMPT TO REPAIR THE UNIT - RETURN IT TO PARKER

SAVING YOUR APPLICATION DATA

In the event of a repair, application data will be saved whenever possible. However, we advise you to backup your application settings before returning the unit.

RETURNING THE UNIT TO PARKER

Please have the following information available:

- The model and serial number - see the unit's rating label
- Detailed information on the nature of the fault as well as a full description of the application and history. This is important to ensure Parker can diagnose to root cause before return.

Contact your nearest please contact your local Parker Service Center to arrange return of the item and to be given a Authorisation To Return (ATR) number. Use this as a reference on all paperwork you return with the faulty item. Pack and despatch the item in the original packing materials; or at least an anti-static enclosure. Do not allow packaging chips to enter the unit. Please include the fault information described above.

Chapter 12: Ethernet

Introduction

Communications to the AC30 is via an Ethernet port on the Control Module. This allows access to:

- The PDQ (Parker Drive Quicktool - the pc programming tool see Appendix D – Programming)
- The Modbus TCP server (see Appendix A - Modbus TCP)
- The HTTP server (see section below)

The Ethernet port operates at 10/100 MHz, half/full duplex. Internet Protocol version 4 (IPv4) is supported. Connection is recommended via an Ethernet switch.

Connecting to a Network

Insert the Ethernet cable as shown below:

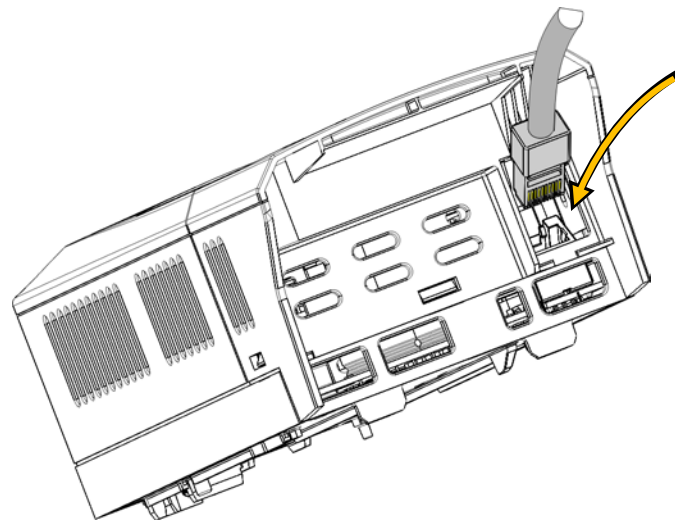

To remove the cable first remove the GKP and then insert a screwdriver to release the catch on the Ethernet clip.

Ethernet LEDs Meaning:

Activity   Link

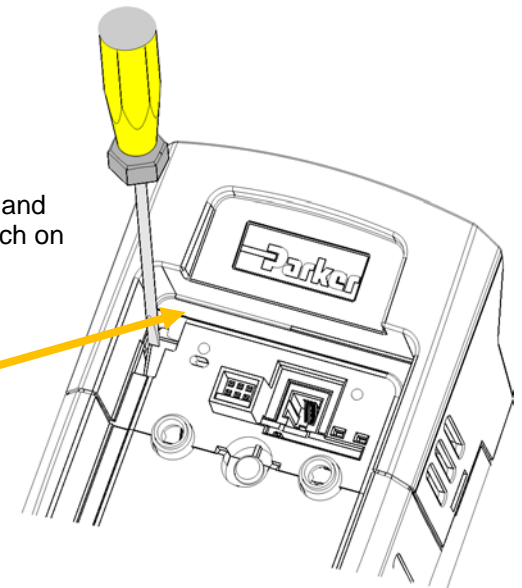

RECOMMENDED CABLE

We recommend using CAT5e screened or CAT6 screened.

12-2 Ethernet

STATUS MONITORING

The MAC address of the Ethernet port is fixed at the factory and can be read using the parameter

0945 MAC Address

The current IP settings of the AC30 can be monitored using the following parameters:

0926 IP Address

0927 Subnet Mask

0928 Gateway Address

The state of the Ethernet can be monitored using the parameter **0919 Ethernet State** and from the Ethernet icon  on the GKP status bar.

Setting the IP Address

To enable communications over the Ethernet an IP address must be set. The IP address may be set:

- Manually to a fixed address
- Automatically by a DHCP server connected on the network
- Automatically by the AC30 to a link-local address using Auto-IP (also known as Automatic Private IP Addressing)

The parameters **0929 DHCP** and **0930 Auto IP** are used to determine how the IP address is set. The factory default of these parameters is TRUE.

The parameter **0936 Setting Lock**, when set to TRUE, prevents a configuration tool from modifying the IP settings.

Manually Setting the IP Address

Parameter	Setting
0929 DHCP	FALSE
0930 Auto IP	FALSE
0933 User IP Address	<i>Preferred IP Address</i>
0934 User Subnet Mask	<i>Preferred Subnet Mask</i>
0935 User Gateway Address	<i>Preferred Gateway Address</i>

To set the IP address manually both the DHCP and Auto-IP must be disabled. The IP address, subnet mask and gateway address will be set from the values in the parameters **0933 User IP Address**, **0934 User Subnet Mask**, **0935 User Gateway Address**.

If the network does not have a gateway to another network then the gateway address may be set to 0.0.0.0

Automatically Assigning an IP Address using DHCP

Parameter	Setting
0929 DHCP	TRUE
0930 Auto IP	FALSE

If the network on which the AC30 is connected has a DHCP (Dynamic Host Configuration Protocol) server then the IP address may be assigned by this server. The DHCP must be enabled. The AC30 will then request an IP address, subnet mask and gateway address from the DHCP server.

Note: The IP address is requested by the AC30 each time the drive is powered up or when the Ethernet cable is plugged in. There is no guarantee that the DHCP server will provide the same IP address each time.

Automatically Assigning an IP Address using Auto-IP

Parameter	Setting
0929 DHCP	FALSE
0930 Auto IP	TRUE

The AC30 may assign itself a link-local address automatically using Auto-IP. This would be used where an automatic address is required but where no DHCP server is available, such as a small local network or when connecting an AC30 drive directly to a PC (point to point). The Auto-IP must be enabled.

The AC30 will choose an IP address randomly from the link-local range **169.254.*.***. The AC30 checks that no other Ethernet device on the network is using the address before allocating it. The AC30 will store this IP address (in parameter **0931 Last Auto IP Address**) and attempt to use it next time Auto-IP is used. The gateway address is fixed to 0.0.0.0

Using Both DHCP and Auto-IP

Parameter	Setting
0929 DHCP	TRUE
0930 Auto IP	TRUE
0932 DHCP To Auto IP	<i>The timeout in seconds before DHCP gives up and an IP address is obtained using Auto-IP</i>

If both the DHCP and Auto-IP are enabled then an IP address will be obtained automatically depending on the network. First an attempt will be made to obtain an IP address from a DHCP server (if connected). If after a timeout period a DHCP server is not available then a link-local address will be obtained using Auto-IP.

Note: If an Auto-IP address is used and subsequently a DHCP server becomes available, no further request will be made to the DHCP server until either the Ethernet cable is disconnected and reconnected or the AC30 is power cycled.

12-4 Ethernet

Typical Wiring Configurations

Point to Point Connection

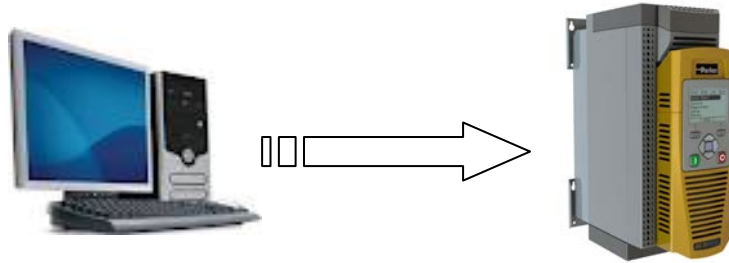

When connecting a PC directly to an AC30 drive either:

- Both sides use local-link addresses 169.254.*.* (recommended) , or
- Both sides are set with a fixed IP address (each must be different and on the same subnet)

When using local-link addresses the parameter **0930 Auto IP** must be set to TRUE (see the section *Automatically Assigning an IP Address using Auto-IP*). Normally the PC is already configured to allow for an Automatic Private IP address. However if problems are encountered check the PC's network settings (see the section 12-10).

Note: It may take the PC up to 2 minutes to obtain an Automatic private IP address when the Ethernet cable is plugged in.

Local Network with a DHCP Server

For the AC30 the parameter **0929 DHCP** must be set to TRUE (see the section *Automatically Assigning an IP Address using DHCP*).

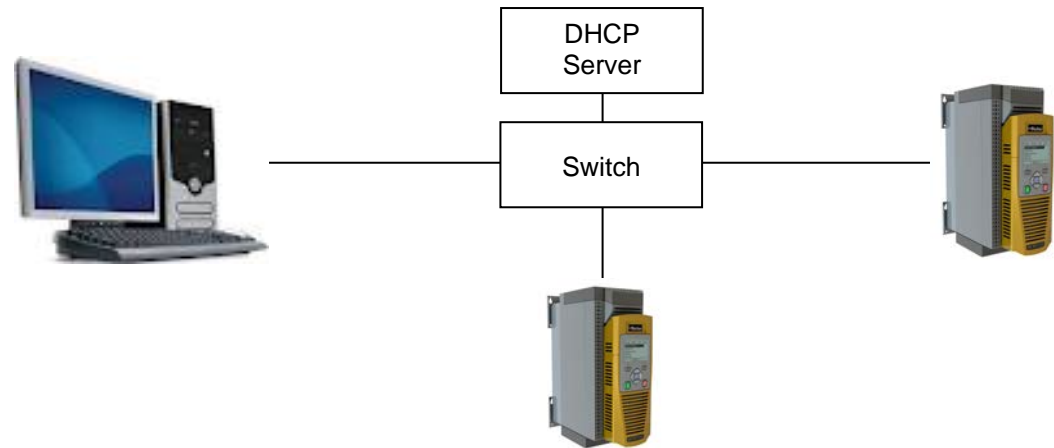

Local Network without a DHCP Server

Devices on the network either:

- Use fixed addresses, in which case the parameters **0929 DHCP** and **0930 Auto IP** must be set to FALSE (see the section *Manually Setting the IP Address*), or
- Use link-local addresses, in which case the parameter **0930 Auto IP** must be set to TRUE (see the section *Automatically Assigning an IP Address using Auto-IP*).

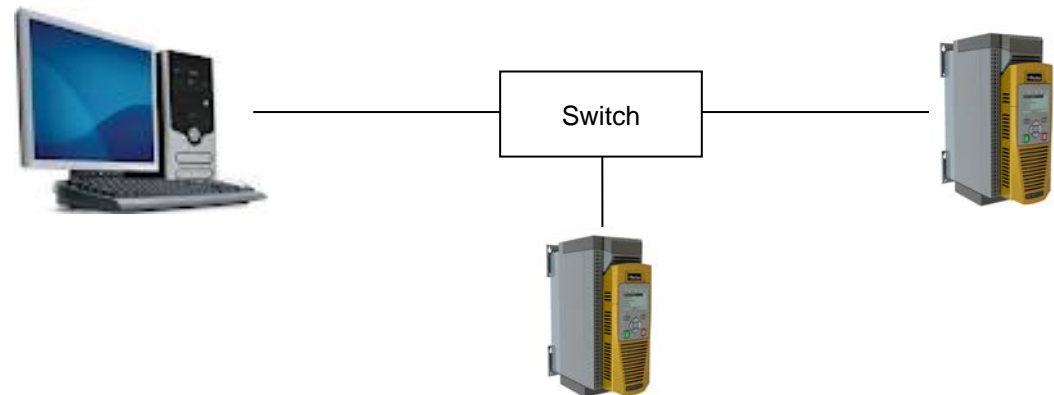

12-6 Ethernet

Web (HTTP) Server

The AC30 has a built-in web server. To access the web server the parameter **0944 Web Access** must be set to **LIMITED** or **FULL**.

To access the AC30 drive, enter the IP address into a web browser. The following browsers are suitable:

- Internet Explorer 8 or above - recommended
- Mozilla Firefox 13 or above
- Google Chrome 19 or above

WEB PAGES

A number of built-in web pages can be accessed from the AC30.

Home Page

The home page displays a summary of the drive.

Parameters Page

The parameters page provides access to the AC30 drive parameters similar to the GKP. This page may only be accessed when the parameter **0944 Web Access** is set to **FULL**. The view level of the parameters may be modified using the parameter **0945 Web View Level**.

Parameters may be modified from this web page. If a parameter is successfully modified, and supports save, it will be saved.

Some parameters may only be modified when in configuration mode, in which case the parameter number will be highlighted **green**. Some parameters may only be modified when the drive is stopped, in which case the parameter number will be highlighted **red**.

It is recommended to use the refresh button provided on the page, rather than on the browser itself, to view the latest parameter values.

Services Page

The services page provides a means of restricting access to the web pages with a password using Basic Authentication. This page may only be accessed when the parameter **0944 Web Access** is set to **FULL**.

If the web access password is set then access to the Parameters Page and Services Page will be restricted. The factory default has the password cleared providing unrestricted access.

The username is fixed to "**ac30**".

Note 1. Basic Authenticate is a very low level of defense against unauthorized access. It is the responsibility of the system administrator to assess the network security and provide adequate protection.

Note 2. The username and password are case sensitive.

Note 3. If passwords are lost, they may only be cleared by a return to factory defaults of all the parameters.

TROUBLESHOOTING THE WEB SERVER

Troubleshooting of the Ethernet in general is described in the section Troubleshooting below.

If the AC30 web page still cannot be accessed then this may be due to the browser's **proxy server** settings, especially if the PC has been used on a corporate network. To check the settings, access the **Internet Options** dialog from within the browser and click on the **Connections** tab, then click on **LAN settings**. Make sure the **Proxy server** checkbox is cleared, alternatively click on **Advanced** and add the IP address of the AC30 to the **Exceptions** list.

Contact your network administrator before making any changes to your browser settings.

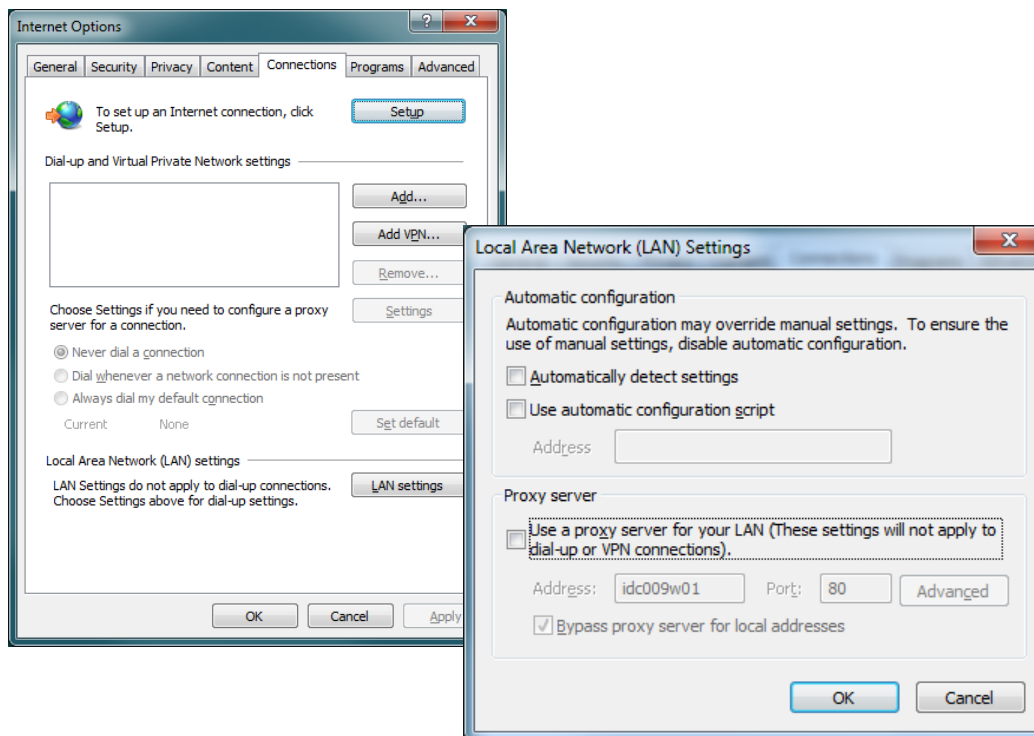

12-8 Ethernet

Troubleshooting

The following parameters are useful for monitoring the IP settings:

0929 IP Address

0928 Subnet Mask

0931 Gateway Address

The state of the Ethernet can be monitored using the parameter **944 Ethernet State**, normal operation is when the state is **RESOLVED IP**, and from the GKP icon 

FLASHING GKP ICON

Normally, once the AC30 is connected to a network, the GKP Ethernet icon will flash for a short period as the IP address is being resolved, and then will become a solid icon indicating an IP address has been set. If the icon continues to flash for more than 1 – 2 minutes this can indicate a problem. Check the parameter **0919 Ethernet State**.

RESOLVING IP

The AC30 is waiting for a valid IP address to be set manually using the parameters:

0933 User IP Address

0934 User Subnet Mask

0935 User Gateway Address

Note that the IP address must be set to a non-zero value.

RESOLVING DHCP

The AC30 is waiting for a DHCP server to provide an IP address. If there is no DHCP server detected on the network then the Ethernet will stay in this state. If there is no DHCP server the IP address may be obtained using Auto-IP or set manually.

DUPLICATE IP

Another device on the network with the same IP address has been detected. This will cause communication issues. The Duplicate IP warning will clear after approximately 1 minute once the conflicting device has been removed or the IP address changed.

AN IP ADDRESS IS SET BUT THERE IS NO COMMUNICATION

If there is an IP address set but there are problems communicating with other devices (say a PC) then the IP address may not match the subnet on which it is connected. The range of the IP address permitted on a network depends upon the particular network. Normally if the IP address is obtained automatically then the settings will be correct for the network.

The administrator of a network should be aware of what IP settings are required.

LINK DETECTION

When the AC30 Ethernet is connected to a network or other device, the Ethernet Link LED will be on and the Ethernet Activity LED will be flickering.

When first connected, the AC30 will attempt to determine the speed and duplex of the Ethernet link. This is done using a method call auto-negotiation.

Some older devices or hubs do not support auto-negotiation, in which case the AC30 will use parallel detection. As parallel detection will only provide the link speed, the AC30 will default to half-duplex.

12-10 Ethernet

CHANGING THE PC ETHERNET SETTINGS

Normally the PC Ethernet adapter is set to obtain an IP address automatically either from a DHCP server or using an automatic private IP address (Auto-IP). The adapter settings may be checked / modified as follows:

For **Windows XP** under Control Panel → Network Connections

For **Windows 7** under Control Panel → Network And Sharing Center → Change adapter settings

Right-click on the required network adapter and choose Properties, then double-click on **Internet Protocol (TCP/IP)** (Windows XP) or **Internet Protocol Version 4 (TCP/IPv4)** (Windows 7).

To use a fixed IP address make sure **Use the following IP address** under the **General** tab is chosen and enter the required IP address, subnet mask and default gateway.

To use DHCP or Auto-IP make sure **Obtain IP address automatically** under the **General** tab is selected and under the **Alternate Configuration** tab that **Automatic private IP address** is selected.

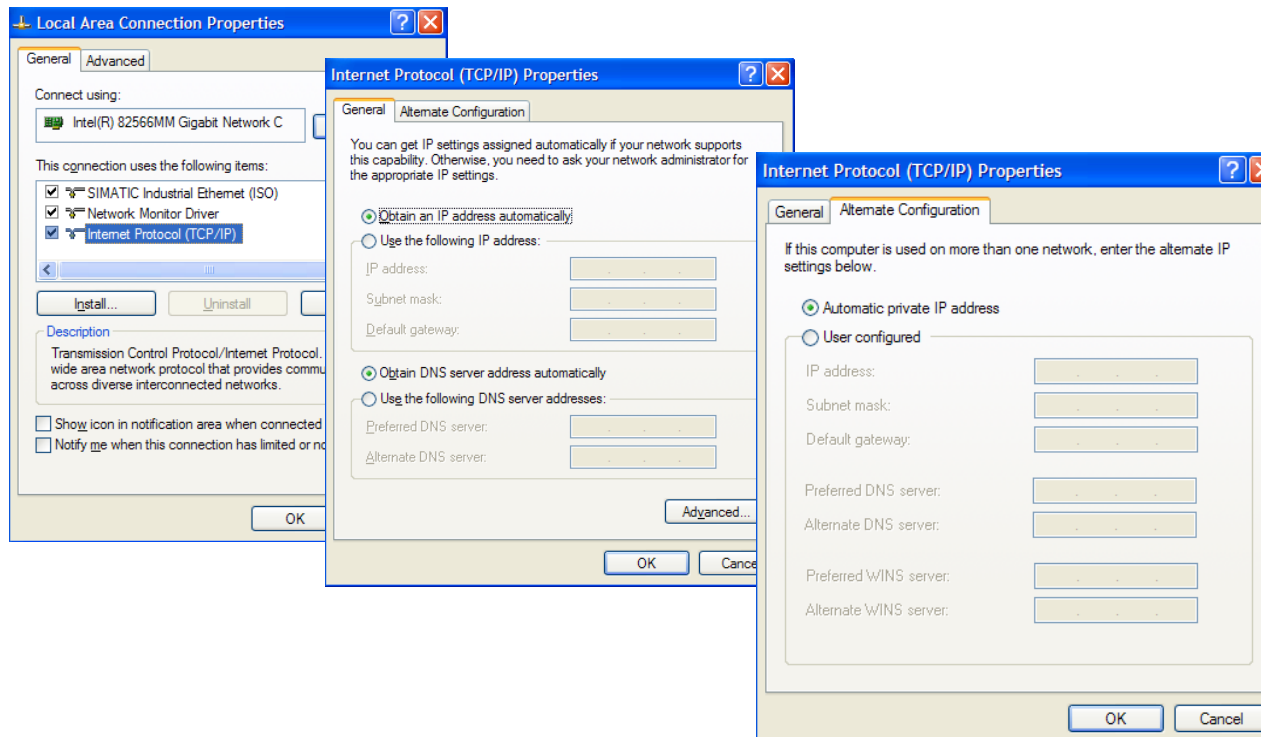

Parameter Summary

PNO Parameter Descriptions

0919 Ethernet State

Type: USINT (enumerated)

Base Communications parameter.

Provides the state of the AC30 Ethernet link.

Range:	RW/RO	Saved	Config
(0) INITIALISING - Driver initialising	RO	x	x
(1) NO LINK - Ethernet not connected to a network			
(2) RESOLVING IP - Waiting for an IP address to be set manually			
(3) RESOLVING DHCP - Waiting for a DHCP server to provide an IP address			
(4) RESOLVING AUTO-IP - Waiting to Auto-IP to provide an IP address			
(5) RESOLVED IP - IP address is set – communication is possible			
(6) STOPPING DHCP - AC30 is stopping the DHCP service			
(7) DUPLICATE IP - Another device on the network has the same IP address			
(8) FAULT - Fault detected			

0920 MAC Address

Type: String

Base Communications parameter.

Provides the state of the AC30 Ethernet link.

Range:	RW/RO	Saved	Config
XX-XX-XX-XX-XX-XX	RO	x	x

12-12 Ethernet

PNO	Parameter Descriptions
-----	------------------------

0926 IP Address
 Type: DWORD(IP address)
 Base Communications parameter.
 Provides the current IP address of the AC30 Ethernet

Range:	RW/RO	Saved	Config
0.0.0.0	RO	x	x
...			
255.255.255.255			

0927 Subnet Mask
 Type: DWORD(IP address)
 Base Communications parameter.
 Provides the current subnet mask of the AC30 Ethernet.

Range	RW/RO	Saved	Config
0.0.0.0	RO	x	x
...			
255.255.255.255			

0928 Gateway Address
 Type: DWORD(IP address)
 Base Communications parameter.
 Provides the current gateway address of the AC30 Ethernet.

Range	RW/RO	Saved	Config
0.0.0.0	RO	x	x
...			
255.255.255.255			

PNO Parameter Descriptions**0931 Last Auto IP Address**

Type: DWORD(IP address)

Base Communications parameter.

Provides the last Auto-IP IP address used.

Range	RW/RO	Saved	Config
0.0.0.0	RO	x	x
...			
255.255.255.255			

0937 Ethernet Diagnostic

Type: DWORD

Base Communications parameter.

Diagnostic for the AC30 Ethernet.

Range	RW/RO	Saved	Config
0000 0000h	RO	x	x
...			
FFFF FFFFh			

1269 DHCP State

Type: DWORD

Base Communications parameter.

Diagnostic for the AC30 DHCP client.

Range	RW/RO	Saved	Config
0000 0000h	RO	x	x
...			
FFFF FFFFh			

12-14 Ethernet

PNO Parameter Descriptions

0938 Free Packets
 Type: UDINT
 Base Communications parameter.
 Diagnostic for the AC30 Ethernet.

Range	RW/RO	Saved	Config
0 ... UDINT max	RO	x	x

0929 DHCP
 Type: BOOL
 Default: TRUE
 Base Communications parameter.
 DHCP enable.
 Set to TRUE to obtain an IP address from a DHCP server.

Range:	RW/RO	Saved	Config
FALSE TRUE	RW	✓	x

0930 Auto IP
 Type: BOOL
 Default: TRUE
 Base Communications parameter.
 DHCP enable.
 Set to TRUE to obtain an IP address using Auto-IP.

Range	RW/RO	Saved	Config
FALSE TRUE	RW	✓	x

PNO Parameter Descriptions**0932 DHCP To Auto IP**

Type: TIME

Default: 45 seconds

Base Communications parameter.

This is the time taken between attempting to get an IP address from a DHCP server and then attempting to get an IP address using Auto-IP.

Both DHCP and Auto-IP must be enabled.

Range	RW/RO	Saved	Config
30 seconds	RW	✓	✗
...			
300 seconds			

0933 User IP Address

Type: DWORD (IP address)

Default: 0.0.0.0

Base Communications parameter.

The preferred fixed IP address of the AC30 Ethernet.

Both DHCP and Auto-IP must be disabled.

Range	RW/RO	Saved	Config
0.0.0.0	RW	✓	✗
...			
255.255.255.255			

0934 User Subnet Mask

Type: DWORD (IP address)

Default: 0.0.0.0

Base Communications parameter.

The preferred fixed subnet mask of the AC30 Ethernet.

Both DHCP and Auto-IP must be disabled.

Range	RW/RO	Saved	Config
0.0.0.0	RW	✓	✗
...			
255.255.255.255			

12-16 Ethernet

PNO	Parameter Descriptions
-----	------------------------

0935 User Gateway Address
 Type: DWORD (IP address)
 Default: 0.0.0.0
 Base Communications parameter.
 The preferred fixed gateway address of the AC30 Ethernet.
 Both DHCP and Auto-IP must be disabled.

Range	RW/RO	Saved	Config
0.0.0.0 ... 255.255.255.255	RW	✓	✗

0944 Web Access
 Type: USINT (enumerated)
 Default: (1) LIMITED
 Base Communications parameter.

Enables access to the AC30 web server.

Range	RW/RO	Saved	Config
(0) DISABLED – a web browser is prevented from accessing the AC30 web server. (1) LIMITED – a web browser may access a limited set of pages on the AC30 web server. (2) FULL – a web browser has full access to the pages on the AC30 web server, however authentication will be required if a password has been set.	RW	✓	✗

0945 Web View Level
 Type: USINT (enumerated)
 Default: (1) TECHNICIAN
 Base Communications parameter.

Sets the view level when accessing parameters via the web server.

Range	RW/RO	Saved	Config
(0) OPERATOR (1) TECHNICIAN (2) ENGINEER	RW	✓	✗

PNO Parameter Descriptions**0946 Web Password**

Type: String

Default: none

Base Communications parameter.

Sets the password for access to restricted AC30 web pages such as the Parameters Page.

Range	RW/RO	Saved	Config
Password parameter will display ***** when set.	RW	✓	x

A-1 Modbus TCP

Appendix A: Modbus TCP

Introduction

The AC30V built-in Ethernet includes a Modbus TCP server. The Modbus registers are mapped to the AC30V parameters. Up to 3 simultaneous connections to Modbus clients are possible. TCP port 502 is used.

Making a connection to the Ethernet and setting an IP address on the AC30V is described in Chapter 12 (Ethernet). If the Modbus TCP is used as part of a process control it is recommended a dedicated network be used with fixed IP addresses for the AC30V drives.

To allow Modbus TCP connections to the AC30V, the parameter **0939 Maximum Connections** must be set to a value greater than zero.

Modbus Register Mapping

The AC30V parameters are mapped to the Holding Registers and Input Registers. There is no mapping to Coils or Discrete Inputs.

Holding Register Address	Input Register Address	Description
00001 - 00528	00001 - 00528	Reserved area. Do not write into this register range.
00529 - onwards	00529 - onwards	Mapped to AC30V parameter values.

Each parameter number is mapped onto **two** consecutive Modbus registers regardless of the parameter data type. The relationship between the Holding Register or Input Register is given as:

$$\text{Register number} = (\text{parameter number} - 1) * 2 + 529$$

- If the parameter has a data type that uses one byte then it will occupy the low byte of the first register and the high byte will be zero, i.e. the register will not be sign extended.
- If the parameter has a data type that uses two bytes then it will occupy the first register.
- Unused register locations will read zero; writing to that location will have no effect.
- The word order of 32-bit parameters is determined by the AC30V parameter **0940 High Word First**.

ARRAYS

Some parameters have multiple elements and are classified as parameter arrays. A parameter array has a parameter number that represents the *whole* of the array, but also has parameter numbers that represent each *element* of the array. An example is given below.

Array Example

A parameter array called **My Array** has 4 elements.

Parameter Number	Parameter - My Array
152	Whole array
153	index 0
154	index 1
155	index 2
156	index 3

If the parameter number of the whole array is 152, then the parameter number of the element index 0 of the array will be 153, the parameter number of the element index 1 will be 154, etc.

Note: *String* array parameters access their elements via parameter numbers that are calculated in a different way (see [Strings](#)).

Accessing the parameter arrays via the parameter number that represents the whole array is not recommended. This will access only the first four bytes (2 registers) of the array. The array should rather be accessed via its elements.

A-3 Modbus TCP

STRINGS

Strings parameters have a parameter number that represents the whole string. This parameter number is mapped to two registers so limits access to the first four characters. Additional contiguous parameter numbers are set aside so that the whole string can be accessed: one additional parameter number for each four characters. The strings are packed into the registers **low byte first**.

String Example

A string parameter called **My String** has a string length of 12 characters (plus the null terminator). This will have one parameter number allocated for the whole string (in this example 161) and 3 further parameter numbers for the string fragments (162-164).

If the value of the string is "0123456789AB":

Parameter Number	Represents		Register Number	Register Value	
				hi-byte	lo-byte
0161	whole string		00849	'1'	'0'
	"0123456789AB"		00850	'3'	'2'
0162		Fragment	00851	'1'	'0'
		"0123"	00852	'3'	'2'
0163		fragment "4567"	00853	'5'	'4'
			00854	'7'	'6'
0164		fragment "89AB"	00855	'9'	'8'
			00856	'B'	'A'

Note: This is an example parameter.

As each AC30V parameter maps to two registers, if the registers that represent the whole string are accessed then only the first four characters will appear. To access the whole string over Modbus use the registers that map to the parameter number of the whole array plus one, in this example **0162** (register **00851**). A multiple read or write of registers will then provide access to the whole string.

String Array Example

A string array parameter called **My String Array** has 2 elements of string length 5 characters (plus the null terminator) each. In this example the parameter number of the whole array is 175.

If the values of the array elements are “12345” and “abc”:

Parameter Number	Represents		Register Number	Register Value	
				hi-byte	lo-byte
0175	whole array [“12345”, “abc”]		00877	'2'	'1'
			00878	'4'	'3'
0176	1 st element “12345”		00879	'2'	'1'
			00880	'4'	'3'
0177	fragment “1234”		00881	'2'	'1'
			00882	'4'	'3'
0178	fragment “5”		00883	<i>null</i>	'5'
			00884	<i>undefined</i>	<i>undefined</i>
0179	2 nd element “abc”		00885	'b'	'a'
			00886	<i>null</i>	'c'
0180	fragment “abc”		00887	'b'	'a'
			00888	<i>null</i>	'c'
0181	fragment “”		00889	<i>undefined</i>	<i>undefined</i>
			00890	<i>undefined</i>	<i>undefined</i>

Note: This is an example parameter.

To access the first element of the array over Modbus then parameter number **0177** (register **00881**) would be used. To access the second element then parameter number **0180** (register **00887**) would be used.

Supported Modbus Functions

Four Modbus functions are supported:

READ HOLDING REGISTERS (#3)

This function allows multiple Input registers to be read. Up to 125 registers may be read. As the Holding registers and Input registers map to the same AC30V parameters this will return the same values as the Read Input Registers function.

READ INPUT REGISTERS (#4)

This function allows multiple Holding registers to be read. Up to 125 registers may be read. As the Holding registers and Input registers map to the same AC30V parameters this will return the same values as the Read Holding Registers function.

WRITE SINGLE REGISTER (#6)

This function allows a single Holding register to be written to. Note that this function may only be used on registers that map to 1-byte or 2-byte AC30V parameters. An attempt to write to a register that maps to a 4-byte parameter will have no effect on the parameter.

WRITE MULTIPLE REGISTERS (#16)

This function allows a contiguous block of Holding registers to be written to. Up to 120 registers may be written. Note that when writing to registers that map to 4-byte AC30V parameters both registers must be written to. Writing to one-half of a 4-byte parameter will have no effect on the parameter.

Modbus Exception Codes

Three Modbus exception codes are supported:

ILLEGAL FUNCTION (01)

The Modbus function is not supported by the slave.

ILLEGAL DATA ADDRESS (02)

If the register data address contained in the Modbus request maps to an AC30V parameter that is outside the range of parameter numbers then this exception will occur.

ILLEGAL DATA VALUE (03)

If the number of bytes or words contained in the Modbus request field is out of range then this exception will occur.

Process Active and Lost Communications Trip

PROCESS ACTIVE FLAG

The Process Active flag is represented by the AC30V parameter **0943 Process Active**. This parameter changes to TRUE on the first valid Modbus request.

If the parameter **0941 Modbus Timeout** is set to a non-zero value then the **Process Active** parameter will subsequently change to FALSE if a Modbus request is not received within the timeout period or if all connections are closed. Note that the connection timeout on the AC30V is 10 seconds.

The parameter **1241 Open Connections** indicates the number of open connections to the AC30V Modbus TCP server.

TRIP

If enabled, a break in the Modbus communications can be used to generate a trip. The **0943 Process Active** parameter is used to generate the trip. If this parameter transitions from TRUE to FALSE then a trip will event will be generated.

To enable the base communications Modbus trip, the parameter **0942 Modbus Trip Enable** must be set to TRUE *and* the **BASE MODBUS BREAK** bit set in the parameter **0697 Enable 1-32**. The parameter **0941 Modbus Timeout** must be set to a value other than zero.

For information on enabling trips see Chapter 10 Trips & Fault Finding.

A-7 Modbus TCP

Parameter Summary

The following parameters are relevant to the Modbus TCP.

PNO	Parameter Descriptions				
0939	Maximum Connections Type: USINT Default: 0 Base Communications Modbus TCP parameter. Sets the maximum number of Modbus clients allowed. If set to zero, then no connections will be allowed.	Range	Writable	Saved	Config
		0 ... 3	✓	✓	✗
0940	High Word First Type: BOOL Default: FALSE Base Communications Modbus TCP parameter. If set to TRUE, the most significant word of a 32-bit parameter will be mapped to the first register, and the least significant word to the next register.	Range	Writable	Saved	Config
		FALSE TRUE	✓	✓	✗
0941	Modbus Timeout Type: TIME Default: 3.0 seconds Base Communications Modbus TCP parameter. Sets the process active timeout	Range	Writable	Saved	Config
		0 ... 65.0 seconds	✓	✓	✗

PNO Parameter Descriptions

0942 Modbus Trip Enable
 Type: BOOL
 Default: FALSE
 Base Communications Modbus TCP parameter.

Set TRUE to enable the Modbus Trip. The parameter **Modbus Timeout** must be set to a value other than zero

Range	Writable	Saved	Config
FALSE TRUE	✓	✓	✗

1241 Open Connections
 Type: USINT
 Base Communications Modbus TCP parameter.

Indicates the number of open connections to the AC30V Modbus TCP server.

Range	Writable	Saved	Config
0 ... 3	✗	✗	✗

0943 Process Active
 Type: BOOL
 Base Communications Modbus TCP parameter.

Indicates that a Modbus request addressed to this node has been received within the period set by the parameter **Modbus Timeout**, or if no timeout is specified, this parameter will stay active after the first received Modbus request.

Range	Writable	Saved	Config
FALSE TRUE	✗	✗	✗

B-1 Sequencing Logic

Appendix B: Sequencing Logic

Drive State Machine

DS402

The sequencing of the AC30V is based on the DS402 / DriveCOM / IEC 61800-7 standard as used by most industrial fieldbuses. This allows it to be easily controlled and monitored by a PLC using the standards' Control Word and Status Word.

SEQUENCING STATE

The sequencing state of the unit is indicated by an enumerated value given by the **0678 Sequencing State** parameter.

Value	DS402 Sequencing State	Description
0	NOT READY TO SWITCH ON	Not ready to switch on. The drive is initialising or being configured.
1	SWITCH ON DISABLED	The Drive will not accept a switch on command
2	READY TO SWITCH ON	The Drive will accept a switch on command.
3	SWITCHED ON	The Drive will accept an Operation Enable (Run or Jog) command. - Power stage of the Drive is ready to operate. - Voltage has not yet been applied to the motor terminals.
4	OPERATIONAL ENABLED	Normal operational state of the drive. This state includes Running, Jogging, Stopping (Disabling Operation) and Shutting Down (Switching Off). - Voltage applied to the motor terminals.
5	QUICKSTOP ACTIVE	Emergency stop (Fast stop) is active
6	FAULT REACTION ACTIVE	The Drive is processing a trip event
7	FAULTED	The Drive is tripped awaiting trip reset

SEQUENCING DIAGRAM

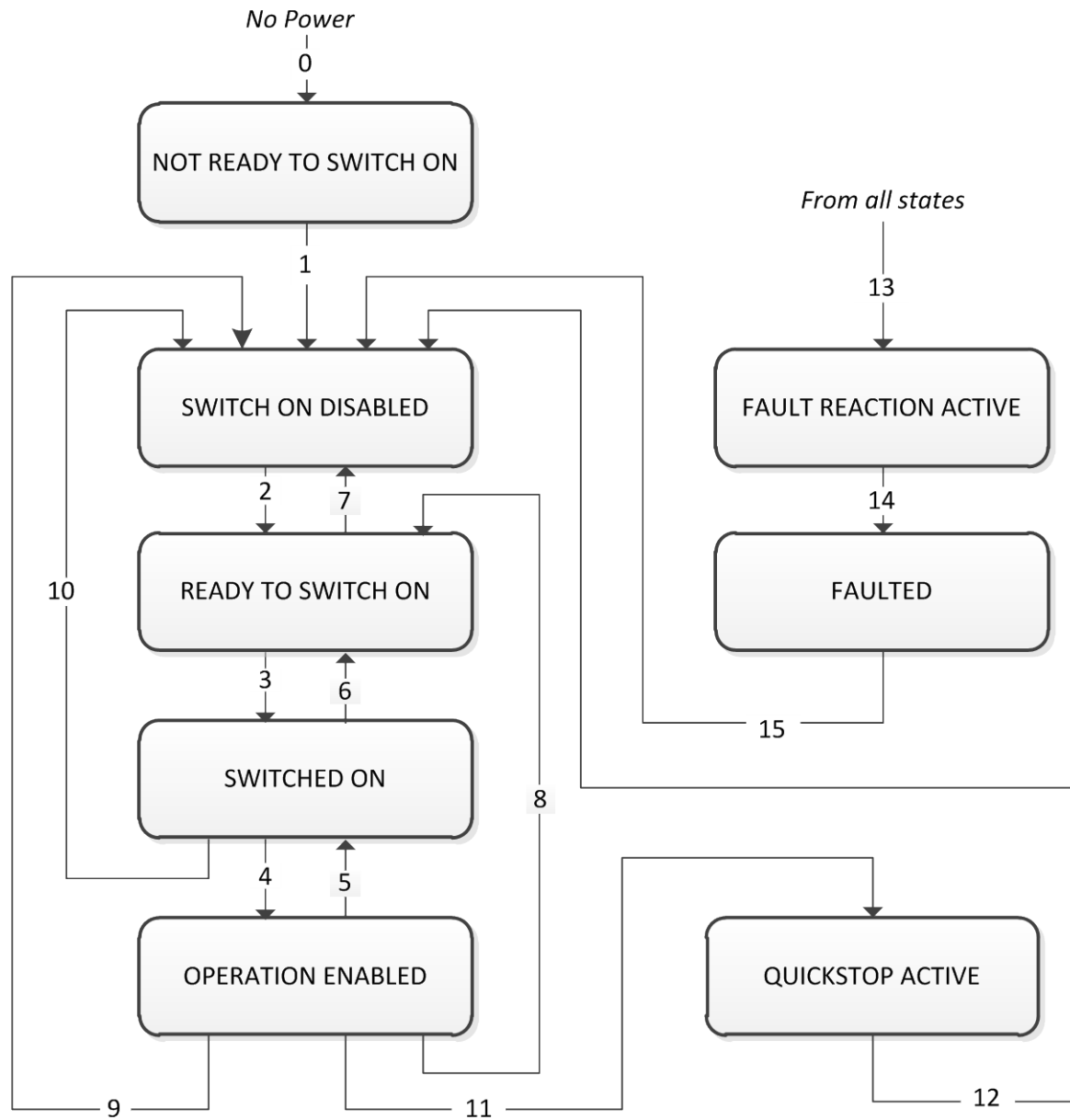

B-3 Sequencing Logic

The OPERATION ENABLED state is the normal operation state of the Drive. In this state the Reference Ramp is active, generating a Speed Demand. Sub-states and allowed transitions are shown below. Note – the RUNNING sub-state also includes JOGGING.

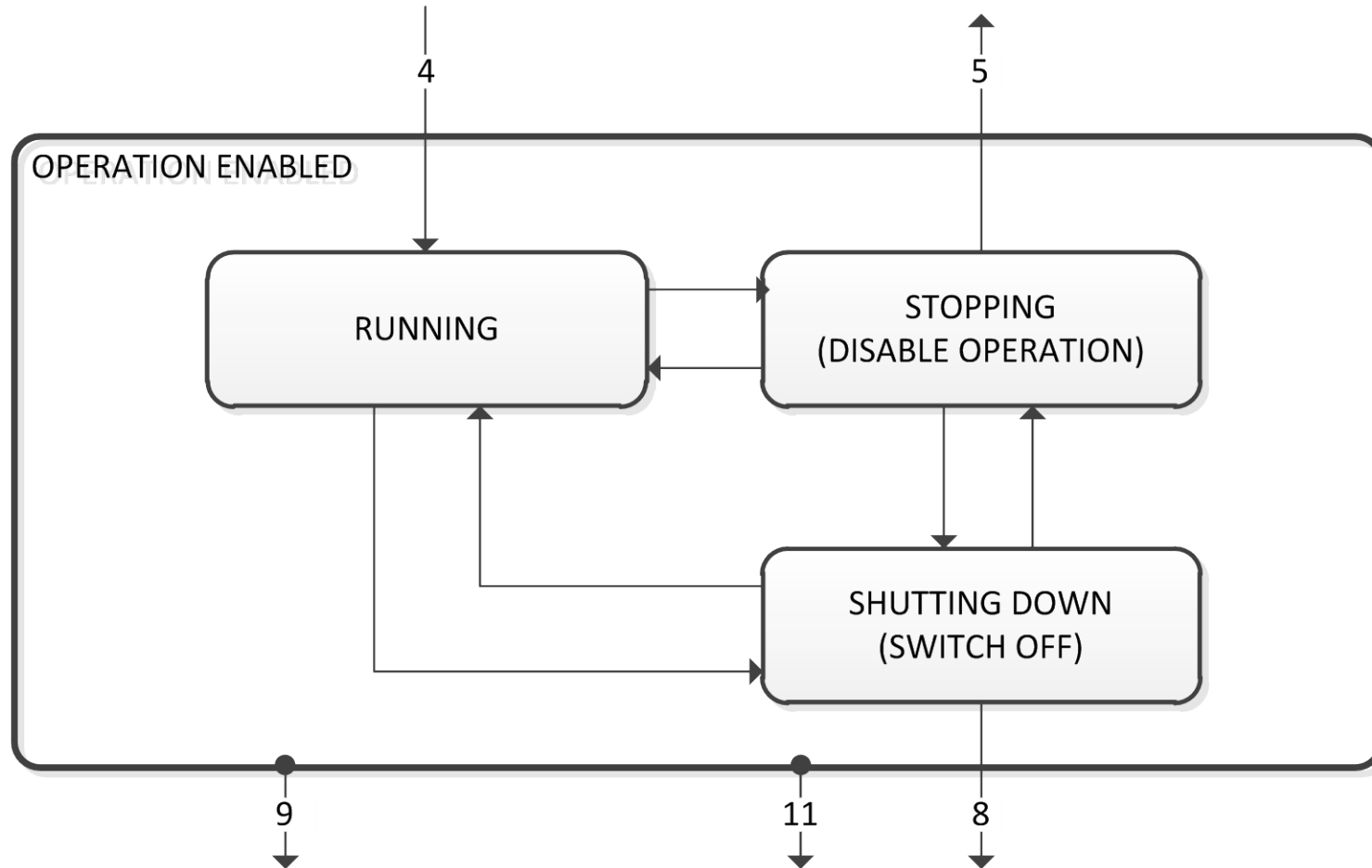

STATE TRANSITIONS

State transitions are caused by internal events in the Drive or external commands via the Control Word. The transition numbers below relate to those on the Sequence Diagram.

Transition 0: No Power to NOT READY TO SWITCH ON

Power has been applied to the control electronics of the drive.

Transition 1: NOT READY TO SWITCH ON to SWITCH ON DISABLED

Automatic transition when initialisation has been completed and application has been loaded.

Transition 2: SWITCH ON DISABLED to READY TO SWITCH ON

Shutdown command received from control device or local signal.

Transition 3: READY TO SWITCH ON to SWITCHED ON

Switch On command received from control device or local signal.

Transition 4: SWITCHED ON to OPERATION ENABLED

Enable Operation (Run Forward, Run Reverse or Jog) command received from control device or local signal.

Transition 5: OPERATION ENABLED to SWITCHED ON

Disable Operation (Stop) command received from control device or local signal and Disabling (Stopping) function completed.

Transition 6: SWITCHED ON to READY TO SWITCH ON

Shutdown command received from control device or local signal.

Transition 7: READY TO SWITCH ON to SWITCH ON DISABLED

Quick Stop or Disable Voltage command received from control device or local signal.

Transition 8: OPERATION ENABLED to READY TO SWITCH ON

Shutdown command received from control device or local signal and Shutdown function completed.

Transition 9: OPERATION ENABLED to SWITCH ON DISABLED

Disable Voltage command received from control device or local signal.

Transition 10: SWITCHED ON to SWITCH ON DISABLED

Disable Voltage or Quick Stop command received from control device or local signal.

Transition 11: OPERATION ENABLED to QUICKSTOP ACTIVE

Quick Stop command received from control device or local signal.

Transition 12: OPERATION ENABLED to QUICKSTOP ACTIVE

Automatic transition when the Quick Stop function is completed or Disable Voltage command received.

Transition 13: any state to FAULT REACTION ACTIVE

Fault (Trip) occurred.

Transition 14: FAULT REACTION ACTIVE to FAULT

Automatic transition when Fault Reaction function completed or Disable Voltage command received.

Transition 15: FAULT to SWITCH ON DISABLED

Fault Reset command received from control device or local signal and there are no active faults.

B-5 Sequencing Logic

CONTROL WORD

The commands that request a change in sequencer state are received via the Control Word. The current value is given by **0644 Control Word**. This is a read-only parameter which is updated from a source depending on the selected sequencing control channel. The sources available are COMMS, APP and LOCAL.

If COMMS is selected, the value will be taken from **0627 Comms Control Word**. This will normally be written to over either the Fieldbus interface or built-in Ethernet Modbus TCP. The Not Quickstop, Enable Voltage and Switch On bits are ANDed with **0627 App Control Word**.

If APP is selected, the value will be taken from **0627 App Control Word**. This will normally be written to by the loaded application which is responsible for routing the control signals from Digital Input terminals.

If LOCAL is selected, the value will be written to by the GKP with the Not Quickstop, Enable Voltage and Switch On bits from **0627 App Control Word**.

Bit	Name	Description
0	Switch On	OFF1 = 1 to switch on
1	Enable Voltage	OFF2 = 0 to coast stop
2	Not Quickstop	OFF3 = 0 to emergency stop
3	Enable Operation	1 = Run
4	Enable Ramp Output	=0 to set ramp output to zero <i>Not implemented, See note below</i>
5	Enable Ramp	=0 to hold ramp <i>Not implemented, See note below</i>
6	Enable Ramp Input	=0 to set ramp input to zero <i>Not implemented, See note below</i>
7	Reset Fault	Reset trips on 0 to 1 transition
8		<i>unused</i>
9		<i>unused</i>
10	Use Comms Control	1 = Use 0627 Comms Control Word as the Control Word source for sequencing
11	Use Comms Reference	1 = Use 0628 Comms Reference as the Reference source
12	Use Jog Reference	1 = Run using 0628 Jog Setpoint when Enable Operation = 1
13	Reverse Direction	1 = Run in reverse direction when Enable Operation = 1
14	Auto Initialise	1 = Allow SWITCH ON DISABLED to READY TO SWITCH ON transition regardless of bit 0 (Switch On)
15	Event Triggered OP	1 = Rising-edge of Enable Operation required for SWITCHED ON to OPERATION ENABLED transition

Note – bits 4, 5, 6 must be set (= 1) to allow the ramp control feature to be added in the future.

Example Comms Control Words (hexadecimal):

CC77 STOP (Normal) or go to SWITCHED ON state
 CC7F RUN
 CC7B QUICKSTOP
 CC7D COAST STOP
 CCF0 FAULT RESET

STATUS WORD

The Status Word provides the detailed status of the sequencer. Regardless of the source of the Control Word, this is always available as **0611 Status Word**.

Bit	Name	Description
0	Ready To Switch On	Drive initialised and not in Configuration mode
1	Switched On	Drive in SWITCHED ON or OPERATION ENABLED state
2	Operation Enabled	Running (or stopping)
3	Faulted	Unacknowledged fault present
4	Voltage Enabled	Line supply present
5	Quickstop Inactive	= 0 when reacting to a Quickstop request
6	Switch On Disabled	Drive in SWITCH ON DISABLED state
7		<i>unused</i>
8		<i>unused</i>
9	Control From Comms	Using 0627 Comms Control Word as the Control Word source
10		<i>unused</i>
11		<i>unused</i>
12	Jog Operation	Using Jog Reference or will use Jog Reference when Operation Enabled
13	Reverse Operation	Running backwards or will run backward when Operation Enabled
14	Reference From Comms	Using 0628 Comms Reference as the Reference source
15	Stopping	Operation Enable command removed or Quickstop active

C-1 Compliance

Appendix C: Compliance

This Chapter outlines the compliance requirements and product certifications.

	Attention – hot surfaces		DANGER Risk of electric shock		Caution Refer to documentation		Earth/Ground Protective Conductor Terminal
-----------------------------------------------------------------------------------	---------------------------------	-----------------------------------------------------------------------------------	-----------------------------------------	-------------------------------------------------------------------------------------	------------------------------------------	-------------------------------------------------------------------------------------	------------------------------------------------------

APPLICABLE STANDARDS

EN 61800-3:2004	Adjustable speed electrical power drive systems – Part 3: EMC requirements and specific test methods.
EN 61800-5-1:2007	Adjustable speed electrical power drive systems – Part 5-1: Safety requirements – Electrical, thermal and energy.
EN 61800-5-2:2007	Adjustable speed electrical power drive systems – Part 5-2: Safety requirements – Functional.
EN ISO 13849-1:2008	Safety of machinery – Safety-related parts of control systems – Part 1: General principles for design.
EN 60204-1:2006	Safety of machinery – Electrical equipment of machines – Part 1: General requirements.
EN 61000-3-2:2006	Electromagnetic Compatibility (EMC) - Part 3-2: Limits – Limits for harmonic current emissions (equipment input current up to and including 16A per phase).
IEC 61000-3-12:2011	Electromagnetic compatibility (EMC) – Part 3-12: Limits – Limits for harmonic currents produced by equipment connected to public low-voltage systems with input currents >16A and ≤75A per phase.
EN 61000-6-2:2007	Electromagnetic compatibility (EMC) – Part 6-2: General standards – Immunity for industrial environments.
EN 61000-6-3:2007	Electromagnetic compatibility (EMC) – Part 6-3: General standards - Emission standard for residential, commercial and light-industrial environments.
EN 61000-6-4:2007	Electromagnetic compatibility (EMC) – Part 6-4: General standards – Emission standard for residential, commercial and light-industrial environments.
UL508C	Standard for Safety, Power Conversion Equipment, third edition.
CSA 22.2 No.14-10	Industrial Control Equipment
NFPA	National Electrical Code, National Fire Protection Agency, Part 70

EUROPEAN COMPLIANCE

CE MARKING



The CE marking is placed upon the product by Parker Hannifin Manufacturing Ltd to facilitate its free movement within the European Economic Area (EEA). The CE marking provides a presumption of conformity to all applicable directives. Harmonized standards are used to demonstrate compliance with the essential requirements laid down in those relevant directives.

It must be remembered that there is no guarantee that combinations of compliant components will result in a compliant system. This means that compliance to harmonised standards will have to be demonstrated for the system as a whole to ensure compliance with the directive.



Local wiring regulations always take precedence.
Where there are any conflicts between regulatory standards for example earthing requirements for electromagnetic compatibility, safety shall always take precedence.

Low Voltage Directive

When installed in accordance with this manual the product will comply with the low voltage directive 2006/95/EC.



Protective Earth (PE) Connections

Only one protective earth  conductor is permitted at each protective earth terminal contacting point.

The product requires a protective earth conductor cross section of at least 10mm², where this is not possible a second protective earth terminal provided on the VSD (Variable Speed Drive) shall be used. The second conductor should be independent but electrically in parallel.

EMC Directive

When installed in accordance with this manual the product will comply with the electromagnet compatibility directive 2004/108/EC.

The following information is provided to maximise the Electro Magnetic Compatibility (EMC) of VSDs and systems in their intended operating environment, by minimising their emissions and maximising their immunity.

C-3 Compliance

Machinery Directive



When installed in accordance with this manual the product will comply with the machinery directive 2006/42/EC. This product is classified under category 21 of annex IV as 'logic units to ensure safety functions'. All instructions, warnings and safety information can be found in Chapter 6.

This product is a component to be incorporated into machinery and may not be operated alone. The complete machinery or installation using this equipment may only be put into service when all safety considerations of the Directive are fully implemented. Particular reference should be made to EN60204-1 (Safety of Machinery - Electrical Equipment of Machines).

EMC COMPLIANCE



WARNING

In a domestic environment, this product may cause radio interference, in which case supplementary mitigation measures may be required.

Definitions

Category C1

PDS (Power Drive System) of rated voltage less than 1000V, intended for use in the first environment

Category C2

PDS (Power Drive System) of rated voltage less than 1000V, which is neither a plug in device nor a movable device and, when used in the first environment, is intended to be installed and commissioned only by a professional.

Note: A professional is a person or an organisation having necessary skills in installing and/or commissioning power drive systems, including their EMC aspects.

Category C3

PDS (Power Drive System) of rated voltage less than 1000V, intended for use in the second environment and not intended for use in the first environment.

Category C4

PDS (Power Drive System) of rated voltage equal to or above 1000V, or rated current equal to or above 400A, or intended for use in complex systems in the second environment.

First Environment

Environment that include domestic premises, it also includes establishments directly connected without transformers to a low-voltage power supply network which supplies buildings used for domestic purposes.

Note: Houses, apartments, commercial premises or offices in a residential building are examples of first environment locations.

Second Environment

Environment that includes all establishments other than those directly connected to a low-voltage power supply network which supplies buildings used for domestic purposes.

Note: Industrial areas, technical areas of any building fed from a dedicated transformer are examples of second environment locations.

EMC Standards Comparison

The standards are concerned with two types of emission

- Radiated** Those in the band 30MHz – 1000MHz which radiate into the environment
- Conducted** Those in the band 150kHz – 30MHz which are injected into the supply.

RADIATED

The standards have common roots (CISPR 11 & CISPR14) so there is some commonality in the test levels applied in different environments.

Relationship Between Standards

Standards			Limits*
Product Specific	Generic		
EN 61800-3	EN61000-6-3	EN61000-6-4	
Category C1 Table 15	Equivalent	Not applicable	30 – 230MHz 30dB(μV/m) 230 - 1000MHz 37dB(μV/m)
Category C2 Table 15	Not applicable	Equivalent	30 – 230MHz 40dB(μV/m) 230 - 1000MHz 47dB(μV/m)
Category C3 Table 18	These limits have no relationships with the generic standards.		30 – 230MHz 50dB(μV/m) 230 - 1000MHz 60dB(μV/m)

*Adjusted for 10m

C-5 Compliance

CONDUCTED EMISSION

The various standards have common roots (CISPR 11 & CISPR14) so there is some commonality in the test levels applied in different standards and environments.

Relationship Between Standards

Standards			Limits			
Product Specific	Generic		Frequency (MHz)	DB (μ V)		
EN 61800-3	EN61000-6-3	EN61000-6-4		Quasi Peak	Average	
Category C1 Table 14	Equivalent	Not applicable	0.15 - 0.5	66 <i>decreasing with log of frequency to:</i>	56 <i>decreasing with log of frequency to:</i>	
			0.5 - 5.0	56	46	
			5.0 - 30.0	60	50	
Category C2 Table 14	Not applicable	Equivalent	0.15 - 0.5	79	66	
			0.5 - 5.0	73	60	
			5.0 - 30.0	73	60	
Category C3 Table 17	These limits have no relationships with the generic standards.		$I \leq 100A$	0.15 - 0.5	100	90
				0.5 - 5.0	86	76
				5.0 - 30.0	90 <i>decreasing with log of frequency to:</i>	80 <i>decreasing with log of frequency to:</i>
			$I \geq 100A$	0.15 - 0.5	130	120
				0.5 - 5.0	125	115
				5.0 - 30.0	115	105

AC30V EMC COMPLIANCE (4KHZ)

Standard EN 61800-3		Frame D ≤ 2.2kW	Frame D > 2.2kW	Frame E	Frame F	
Conducted emissions	Category C1	Table 14	When fitted with the specified external filter & EMC filter kit, refer to C17-18 Maximum cable length 5 m	When fitted with the specified external filter & EMC filter kit, refer to C17-18 Maximum cable length 5 m	Refer to C-9 for the use of a suitable external filter with the required characteristics	Refer to C-9 for the use of a suitable external filter with the required characteristics
	Category C2	Table 14	Product supplied as a component, a suitable external filter is required	When fitted with an EMC filter kit (internal filter, clamping bracket and ferrite), refer to C-17 Maximum cable length 10 m	When fitted with an EMC filter kit (internal filter, clamping bracket and ferrite), refer to C-17 Maximum cable length 10 m	When fitted with an EMC filter kit (internal filter, clamping bracket and ferrite), refer to C-17 Maximum cable length 10 m
	Category C3	Where I<=100A Table 17		When fitted with an internal filter Maximum cable length 50 m	When fitted with an internal filter Maximum cable length 50 m	When fitted with the specified external filter & EMC filter kit, refer to C17-18 Maximum cable length 25 m
Radiated Emissions	When mounted inside a cubicle with the required attenuation between:					
	Category C1	Table 15	35-100MHz at 15dB	35-100MHz at 5dB	30-150MHz at 20dB	
	Category C2	Table 15	35-100MHz at 5dB	No specific enclosure required	30-150MHz at 10dB	
Category C3	Table 18	No specific enclosure required	No specific enclosure required	No specific enclosure required	No specific enclosure required	
Cable Requirements	Power Supply	Cable Type	Unscreened			
		Segregation	From all other wiring (clean)			
		Length Limit	Unlimited			
	Motor Cable	Cable Type	Screened/Armoured			
		Segregation	From all other wiring (noisy)			
		Screen to Earth	Both ends			
		Output Choke	300 meters maximum			
	External Filter to Drive	Cable Type	Screened/Armoured			
		Segregation	From all other wiring (noisy)			
		Length Limit	0.3 meters			
		Screen to Earth	Both ends			
	Brake Resistor	Cable Type	Screened/Armoured			
		Segregation	From all other wiring (noisy)			
		Length Limit	25 meters			
		Screen to Earth	Both ends			
	Signal/Control	Cable Type	Screened			
Segregation		From all other wiring (sensitive)				
Length Limit		25 meters				
Screen to Earth		Drive end only				

8, 12, 16kHz will require extra filtering.

C-7 Compliance

Radiated Emissions Profile

EN61800-3 - Limits for electromagnetic radiation disturbance in the frequency band 30 MHz to 1000 MHz

Frequency band MHz	Category C1	Category C2
	Electric field strength component Quasi-peak dB(√V/m)	Electric field strength component Quasi-peak dB(√V/m)
30 ≤ f ≤ 230	30	40
230 < f ≤ 1 000	37	47

NOTE: Measurement distance 10 m.

For category C1, if the field strength measurement at 10 m cannot be made because of high ambient noise levels or for other reasons, measurement may be made at 3 m. If the 3 m distance is used, the measurement result obtained shall be normalised to 10 m by subtracting 10 dB from the result. In this case, care should be taken to avoid near field effects, particularly when the PDS (Power Drive System) is not of an appropriately small size, and at frequencies near 30 MHz.

When multiple drives are used 3dB attenuation per drive needs to be added.

Conducted Emissions Profile (Unfiltered Product)

Frame D

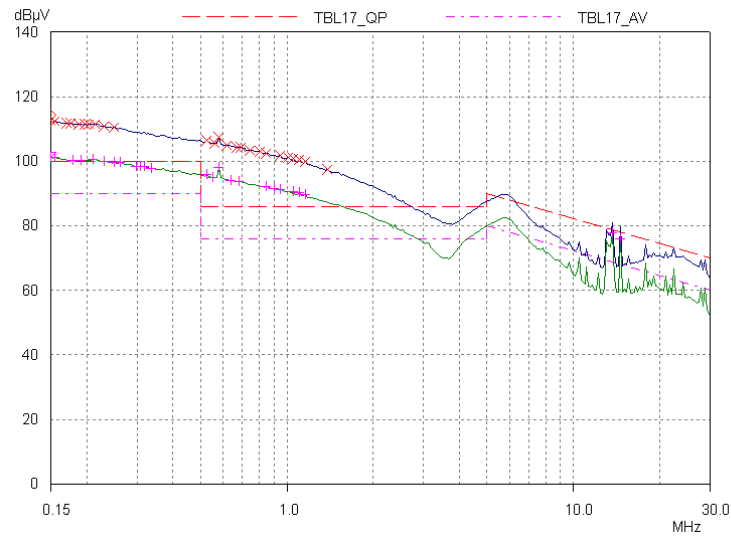

Frame E

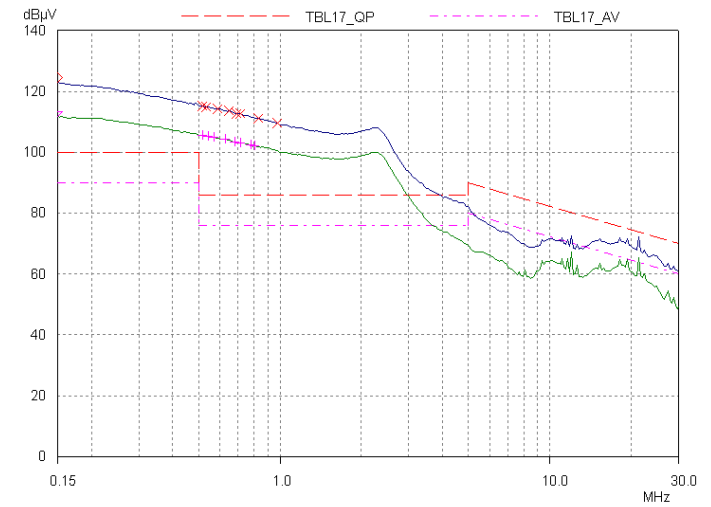

Frame F

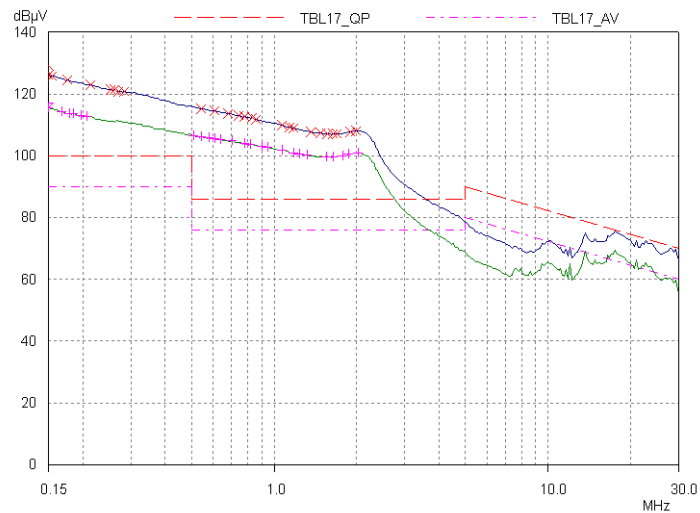

EMC Installation Guidance

PROTECTIVE EARTH (PE) CONNECTIONS



Local wiring regulations take precedence and may require the protective earth connection of the motor to be connected locally, i.e. not as specified in these instructions. This will not cause shielding problems because of the relatively high RF impedance of the local earth connection.

Earthing

A star-point earthing policy separates 'noisy' and 'clean' earths. Four separate earth bus bars (three are insulated from the mounting panel) connect to a single earth point (star point) near the incoming safety earth from the main supply. Flexible, large cross-section cable is used to ensure low HF impedance. Bus bars are arranged so that connection to the single earth point is as short as possible.

1. **0V/Signal Grounding**

The "0V/signal ground" is required to be separately earthed, for multiple products these terminals should be connected together at a single, local earthing point.

2. **Control/Signal and Encoder Cables**

Control/signal and encoder cables, all analogue inputs, and communications require screening with the screen connected only at the VSD end. However, if high frequency noise is still a problem, earth the screen at the non-VSD end via a 0.1 μ F capacitor. Connect the screen (at the VSD end) to the VSD protective earth point  and not to the control board terminals.

3. **Clean Earth Busbar (insulated from the mounting panel)**

Used as a reference point for all signal and control cabling. This may be further subdivided into an analog and a digital reference busbar, each separately connected to the star earthing point. The digital reference is also used for any 24V control.

4. **Dirty Earth Busbar (insulated from the mounting panel)**

Used for all power earths, i.e. protective earth connection. It is also used as a reference for any 110 or 220V control used, and for the control transformer screen.

5. **Metal Work Earth Busbar**

The back panel is used as this earth busbar, and should provide earthing points for all parts of the cubicle including panels and doors. This busbar is also used for power screened cables which terminate near to (10cm) or directly into a VSD- such as motor cables, braking choppers and their resistors, or between VSDs - refer to the appropriate product manual to identify these. Use U-clips to clamp the screened cables to the back panel to ensure optimum HF connection.

6. **Signal/Control Screen Earth Busbar (insulated from the mounting panel)**

Used for signal/control screened cables which **do not** go directly to the VSD. Place this busbar as close as possible to the point of cable entry. 'U' clamp the screened cables to the busbar to ensure an optimum HF connection.

MITIGATING RADIATED EMISSIONS

Equipment Placement

Do not place magnetic/electric field sensitive equipment within 0.25 meters of the following parts of the VSD system:

- *Variable Speed Drive (VSD)*
- *EMC output filters*
- *Input or output chokes/transformers*
- *The cable between VSD and motor (even when screened/armored)*
- *Connections to external braking chopper and resistor (even when screened/armored)*
- *AC/DC brushed motors (due to commutation)*
- *DC link connections (even when screened/armored)*
- *Relays and contactors (even when suppressed)*

Emissions from individual components tend to be additive. To reduce the emissions:

- The equipment must be mounted in a metal cubicle. Refer to EMC Compliance Table on page C-6.
- The cubicle should be as free of openings as is practical. Vent systems suitable for EMC applications are available from cubicle vendors and should be used.

Radiated magnetic and electric fields inside the cubicle will be high and any components fitted inside must be sufficiently immune.

- All cable entry and exits (power, control, and communication) should use screened cable
- Earth screen at both ends connecting to the motor frame and cubicle.
- Use of screened/armored cable between VSD/cubicle and motor containing the motor protective earth (PE) connection is most important. If shielded cable is not available, lay unshielded motor cables in a metal conduit which will act as a shield. The conduit must be continuous with a direct electrical contact to the VSD and motor housing. If links are necessary, use **braid** with a minimum cross sectional area of 10mm².

C-11 Compliance

- Use 360° screen terminations.

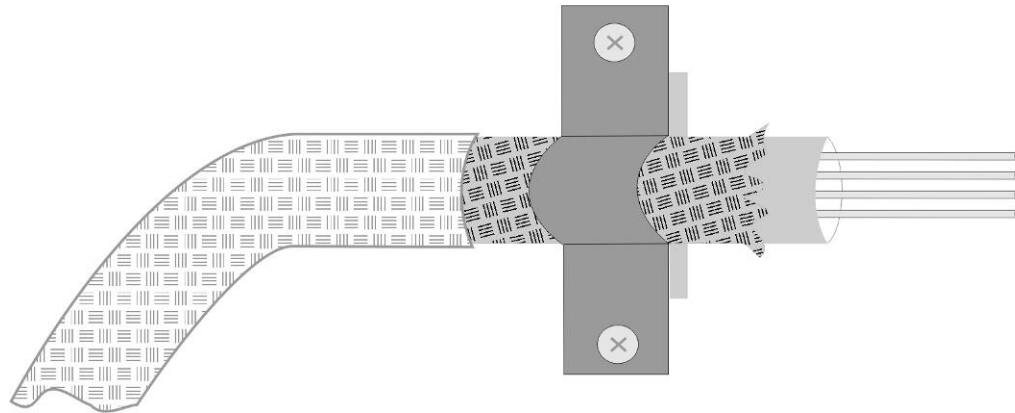

Figure C-1 360 Degree Screened Connection (Motor)

Some hazardous area installations may preclude direct earthing at both ends of the screen, in this case earth one end via a 1 μ F 50Vac capacitor, and the other as normal.

- Keep unshielded cable as short as possible inside the cubicle.
- Always maintain the integrity of the shield. If the cable is interrupted to insert contactors etc., re-connect the screen using the shortest possible route. Some motor gland boxes and conduit glands are made of plastic, if this is the case, then braid must be connected between the screen and the chassis. In addition at the motor end, ensure that the screen is electrically connected to the motor frame since some terminal boxes are insulated from the frame by gasket/paint.
- Keep the length of screen stripped-back as short as possible when making screen connections.

CABLING REQUIREMENTS

Refer to “Recommended Wire Size” page C-26 for calculating wire sizes.

Cable Routing

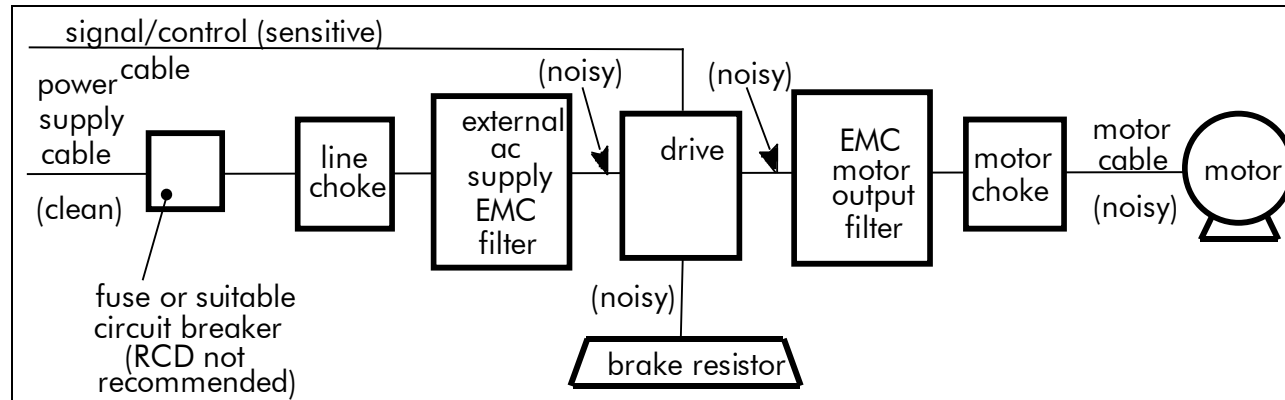

Figure C-2 Cabling Requirements

Cables are considered to be electrically *sensitive*, *clean* or *noisy*. You should already have planned your cable routes with respect to segregating these cables for EMC compliance.

- Use the shortest possible motor cable lengths.
- When connecting multiple motors to a single VSD, use a star junction point for motor cable connections. Use a metal box with entry and exit cable glands to maintain shield integrity.
- Keep electrically noisy and sensitive cables apart.
- Keep electrically noisy and sensitive parallel cable runs to a minimum. Separate parallel cable runs by at least 0.25 metres. For runs longer than 10 metres, separation should be increased proportionally. For example if the parallel runs were 50m, then the separation would be $(50/10) \times 0.25\text{m} = 1.25\text{m}$.
- Sensitive cables should cross noisy cables at 90°.
- Never run sensitive cables close or parallel to the motor, dc link and braking chopper circuit for any distance.
- Never run supply, dc link or motor cables in the same bundle as the signal/control and feedback cables, even if they are screened.
- Ensure EMC filter input and output cables are separately routed and do not couple across the filter.

C-13 Compliance

Increasing Motor Cable Length

Because cable capacitance and hence conducted emissions increase with motor cable length, conformance to EMC limits is only guaranteed with the specified AC supply filter option up to a maximum cable length as specified in the Cabling Requirements for EMC Compliance C-15.

This maximum cable length can be improved using the specified external input or output filters.

Screened/armored cable has significant capacitance between the conductors and screen, which increases linearly with cable length (typically 200pF/m but varies with cable type and current rating).

Long cable lengths may have the following undesirable effects:

- Tripping on 'overcurrent' as the cable capacitance is charged and discharged at the switching frequency.
- Producing increased conducted emissions that degrade the performance of the EMC filter due to saturation.
- Causing RCDs (Residual Current Devices) to trip due to increased high frequency earth current.
- Producing increased heating inside the EMC ac supply filter from the increased conducted emissions.
- These effects can be overcome by adding chokes or output filters at the output of the VSD.



WARNING

**Ensure that all wiring is electrically isolated and cannot be made "live" unintentionally by other personnel.
The drive is suitable for use with IT and TN supplies when fitted with an internal ac supply EMC filter. When used on a IT supply the filter efficiency is reduced resulting in only achieving Category C2 limits.**

EMC Motor Output Filter

This can help the drive achieve EMC and filter thermal requirements. It also ensures longer motor life by reducing the high voltage slew rate and overvoltage stresses. Mount the filter as close to the VSD as possible.

Output Contactors

Output contactors can be used, although we recommend that this type of operation is limited to emergency use only, or in a system where the drive can be inhibited before closing or opening this contactor.

EMC Filter Kit

Frame	EMC Filtering Accessory Kit Numbers
Frame D	LA501935U001
Frame E	LA501935U002
Frame F	LA501935U003

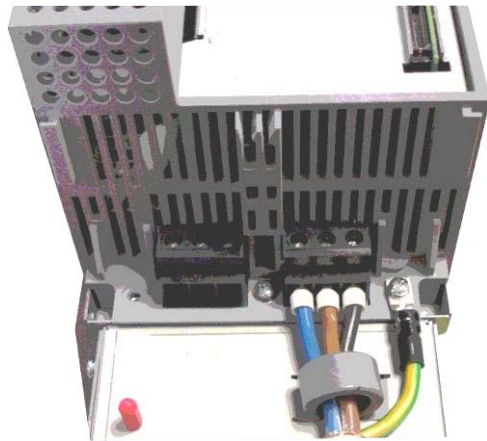

C-15 Compliance

External AC Supply EMC Filter



WARNING

External filters are available for use with TN and IT supplies. When used on a IT supply the filter performance reduces from category C1 to Category C2. Please check for suitability on following page for External AC Supply (RFI) Filters.

Do not touch filter terminals or cabling for at least 3 minutes after removing the ac supply.

Mount the filter as close as possible to the drive.

External Filters for (Frame D, E & F)

They are suitable for wall or cubicle mount, but the filter must be fitted with the appropriate gland box when wall mounted.

Filter Description	Filter Part Number	Terminal Block	Earth Terminal	Dimensions	Fixing Centres	Weight
Frame D & E						
500V IT/TN	CO501894	10mm ²	M6 Stud	272 x 74 x 161mm	258 x 60mm	2.7kg
Frame F						
500V IT/TN	CO501895	50mm ²	M8 Stud	312 x 93 x 190mm	298 x 79mm	3.7kg

Frame D & E Filter Dimensions

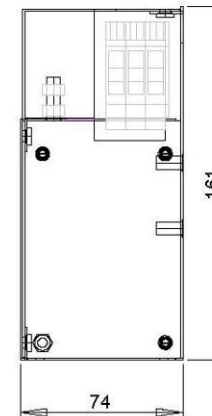
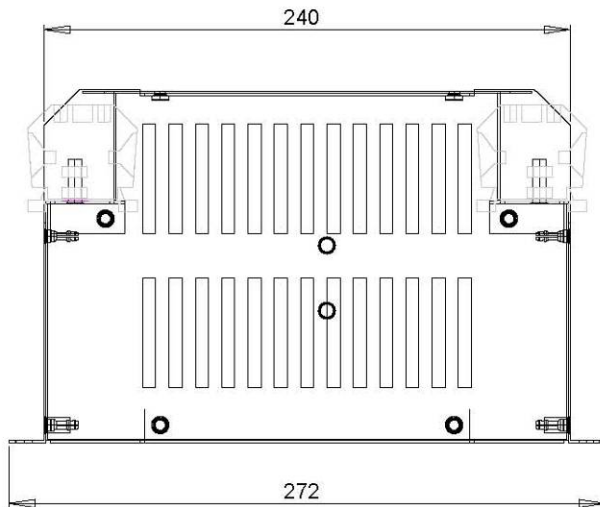
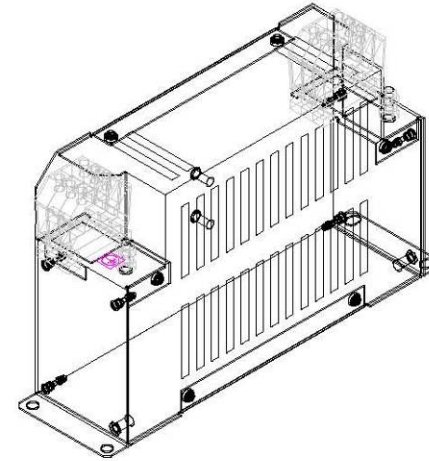
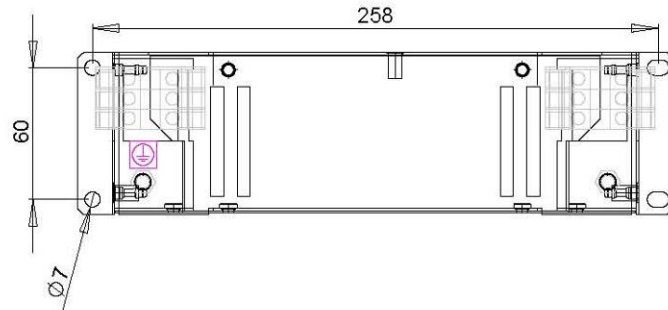

SPECIFICATIONS

VOLTAGE 500Vac
 FREQUENCY 50/60Hz
 CURRENT 36A @ 40°C
 TEMPERATURE - 25 to 100°C
 LEAKAGE CURRENT 81mA @ 500V 50Hz
 HUMIDITY 90% RH (NON-CONDENSING)
 VIBRATION 10-200Hz 1.8G
 ELECTRIC STRENGTH 2250Vac/1min.
 POWER DISSIPATION 16W
 MASS 2.7kg
 TERMINALS 10sq mm TERMINAL BLOCK
 EARTH TERMINALS M6 STUD
 FLANGE MOUNTING 4x M6



C-17 Compliance

Frame F Filter Dimensions

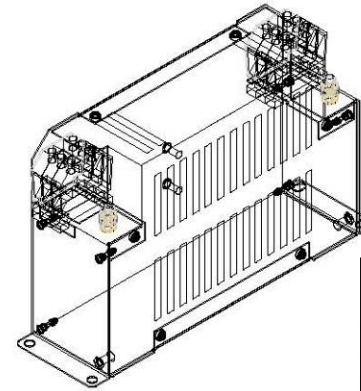
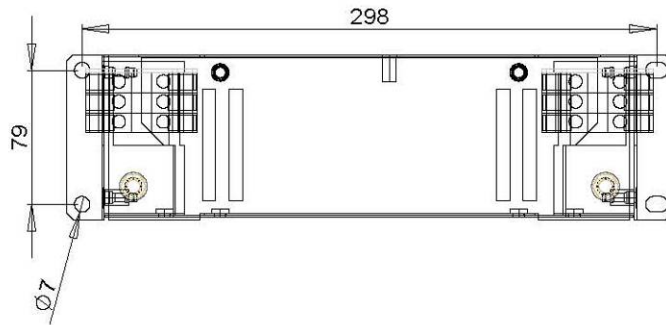

SPECIFICATIONS

VOLTAGE 500Vac
FREQUENCY 50/60Hz
CURRENT 50A @ 40°C
TEMPERATURE - 25 to 100°C
LEAKAGE CURRENT 114mA @ 500V 50Hz
HUMIDITY 90% RH (NON-CONDENSING)
VIBRATION 10-200Hz 1.8G
ELECTRIC STRENGTH 2500Vac/1min.
POWER DISSIPATION 16W
MASS 3.7kg
TERMINALS 50sq mm TERMINAL BLOCK
EARTH TERMINALS M8 STUD
FLANGE MOUNTING 4x M6

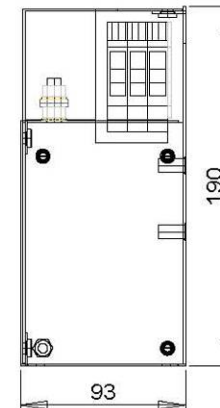
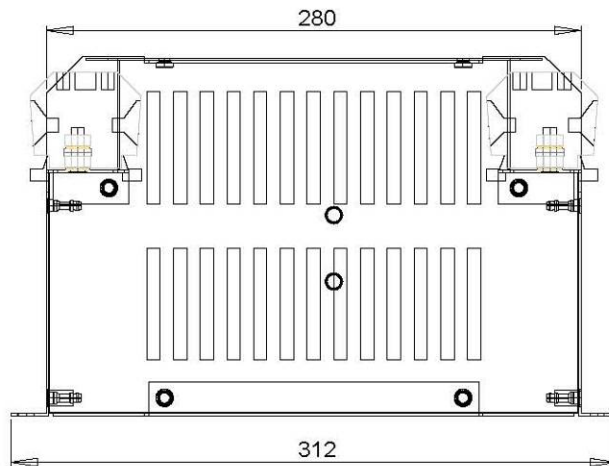

RoHS
2002/95/EC

Compliant

INTERNAL FILTER DISCONNECTION



Disconnection of the EMC filter invalidates the CE EMC Declaration, the product becomes a component for incorporation and the conformity of the complete equipment or installation becomes the responsibility of the installer.

Frame D:

To access the filter disconnect the top and bottom covers, as these need to be removed, then the Control Module, refer to Chapter 4 for removal information. Remove the highlighted screws shown below.

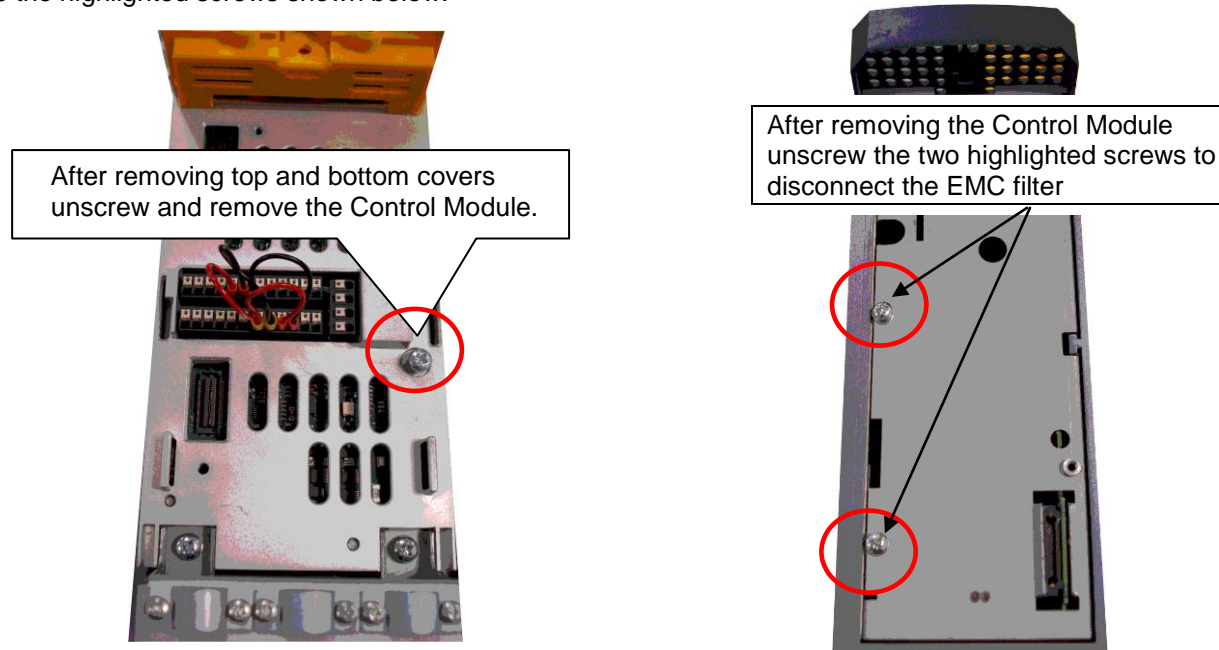

The screw should only be removed once the supply has been disconnected and the residual energy has been discharged.

The product should never be powered or operated without the covers, the EMC filter disconnect will become live once the screw is removed.

C-19 Compliance

Frame E:

To access the filter disconnect the top and bottom covers, as these need to be removed, refer to Chapter 4 for removal information. Remove the highlighted screws shown below.

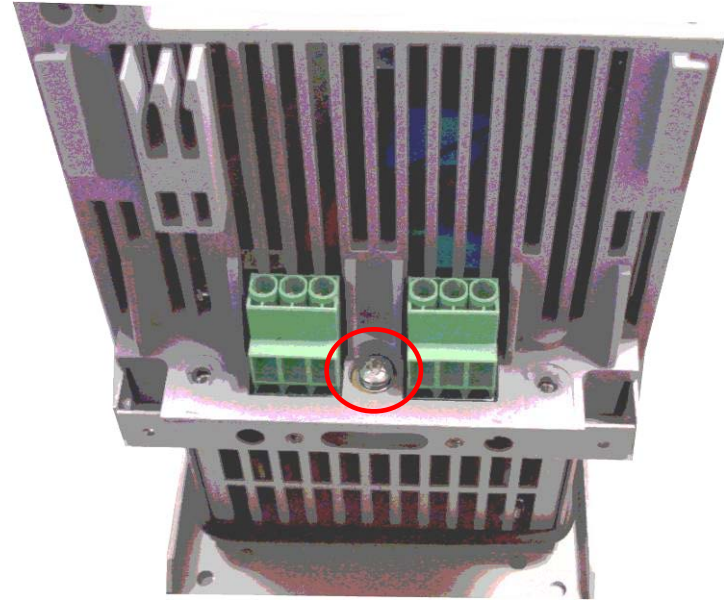

The screw should only be removed once the supply has been disconnected and the residual energy has been discharged.

The product should never be powered or operated without the covers, the EMC filter disconnect will become live once the screw is removed.

Frame F:

To access the filter disconnect the top and bottom covers, as these need to be removed, refer to Chapter 4 for removal information. Remove the highlighted screws shown below.

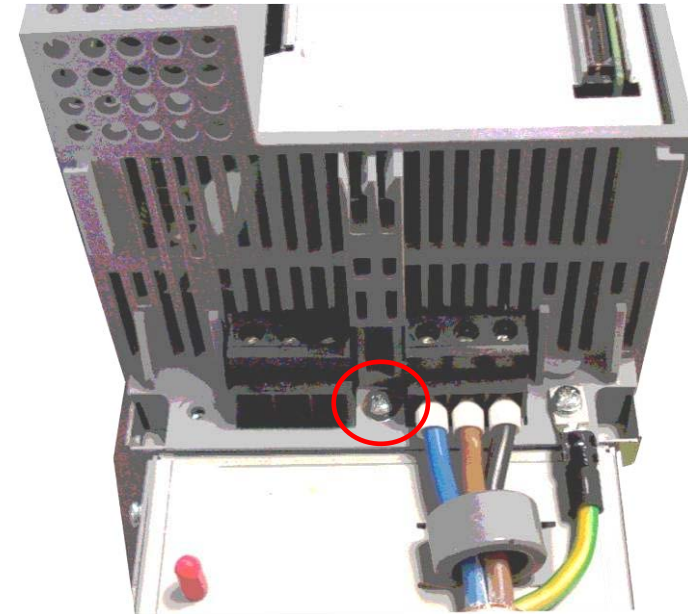

The screw should only be removed once the supply has been disconnected and the residual energy has been discharged.

The product should never be powered or operated without the covers, the EMC filter disconnect will become live once the screw is removed.

C-21 Compliance

Harmonic Information

Supply Harmonic Analysis (Frame D - Normal Duty)													
Assumptions: R _{sce} = 120 at 400V where Q _{1n} is the rated rms value of the fundamental voltage of the supply transformer. The results conform to 61000-3-2:2006+A2:2009.													
Fundamental Voltage (V)		400											
Drive Type		Three Phase											
Motor Power (kW)	1.1	1.5	2.2	3.0	4.0	5.5		1.1	1.5	2.2	3.0	4.0	5.5
Typical Motor Efficiency %	83	83	83	83	83	83		83	83	83	83	83	83
Harmonic No.	RMS Current (A)						Harmonic No.	RMS Current (A)					
1	1.943	2.653	3.946	5.335	7.078	9.694	25	0.064	0.085	0.107	0.140	0.184	0.253
3	0.000	0.000	0.000	0.001	0.001	0.001	27	0.000	0.000	0.000	0.000	0.000	0.000
5	1.479	2.037	2.376	2.573	2.852	3.313	29	0.047	0.067	0.097	0.132	0.175	0.233
7	1.106	1.537	1.636	1.646	1.673	1.745	31	0.037	0.051	0.079	0.107	0.142	0.193
9	0.000	0.000	0.000	0.000	0.000	0.000	33	0.000	0.000	0.000	0.000	0.000	0.000
11	0.406	0.584	0.327	0.446	0.594	0.814	35	0.034	0.046	0.076	0.103	0.135	0.176
13	0.204	0.291	0.354	0.386	0.445	0.558	37	0.030	0.042	0.063	0.086	0.114	0.151
15	0.000	0.000	0.000	0.000	0.000	0.000	39	0.000	0.000	0.000	0.000	0.000	0.000
17	0.153	0.205	0.190	0.259	0.345	0.472	40	0.000	0.000	0.000	0.000	0.000	0.000
19	0.126	0.176	0.167	0.203	0.257	0.349	Total RMS Current (A)	2.73	3.75	4.92	6.19	7.87	10.47
21	0.000	0.000	0.000	0.000	0.000	0.000	* THD (I) %	70.2	70.7	59.8	50.8	43.7	37.8
23	0.065	0.088	0.130	0.178	0.236	0.32							

* (Total Harmonic Distortion)

Supply Harmonic Analysis (Frame E - Normal Duty)

Assumptions: R_{sce} = 120 at 400V where Q_{1n} is the rated rms value of the fundamental voltage of the supply transformer. The results conform to 61000-3-12:2011.

$$THD(V) \times 100 = \frac{\sqrt{\sum_{h=2}^{h=40} Q_{h^2}}}{Q_{1n}} \%$$

Fundamental Voltage (V)	400				
Drive Type	Three Phase				
Motor Power (kW)	7.5	11		7.5	11
Typical Motor Efficiency %	83	86		83	86
Harmonic No.	RMS Current (A)		Harmonic No.	RMS Current (A)	
1	12.801	18.703	25	0.306	0.484
3	0.002	0.002	27	0.000	0.000
5	5.284	6.467	29	0.295	0.448
7	3.010	3.425	31	0.234	0.370
9	0.000	0.000	33	0.000	0.000
11	1.065	1.571	35	0.224	0.338
13	0.769	1.078	37	0.185	0.290
15	0.000	0.000	39	0.000	0.000
17	0.604	0.909	40	0.000	0.000
19	0.433	0.669	Total RMS Current (A)	14.27	20.24
21	0.000	0.000	* THD (I)%	44.2	38.2
23	0.406	0.616			

* (Total Harmonic Distortion)

C-23 Compliance

Supply Harmonic Analysis (Frame F - Normal Duty)

Assumptions: Rsce = 120 at 400V where Q_{1n} is the rated rms value of the fundamental voltage of the supply transformer. The results conform to 61000-3-12:2011.

$$THD(V) \times 100 = \frac{\sqrt{\sum_{h=2}^{h=40} Q_{h^2}}}{Q_{1n}} \%$$

Fundamental Voltage (V)	400				
Drive Type	Three Phase				
Motor Power (kW)	15	18.5		15	18.5
Typical Motor Efficiency %	86	86		86	86
Harmonic No.	RMS Current (A)		Harmonic No.	RMS Current (A)	
1	25.833	30.954	25	0.644	0.803
3	0.006	0.005	27	0.000	0.000
5	9.512	10.517	29	0.608	0.743
7	5.147	5.527	31	0.493	0.613
9	0.001	0.000	33	0.000	0.000
11	2.177	2.618	35	0.459	0.560
13	1.494	1.781	37	0.388	0.480
15	0.001	0.000	39	0.000	0.000
17	1.244	1.513	40	0.000	0.000
19	0.896	1.110	Total RMS Current (A)	28.21	33.41
21	0.000	0.000	* THD (I) %	40.2	37.6
23	0.838	1.024			

* (Total Harmonic Distortion)

Requirements for North American and Canadian Compliance

NORTH AMERICAN COMPLIANCE

This product is certified under the US governments Occupational Safety and Health Administration's (OSHA), Nationally Recognised Testing Laboratory (NRTL) program. An NRTL is a private third party organisation accredited by OSHA to test and certify products to national standards for compliance with North American requirements.

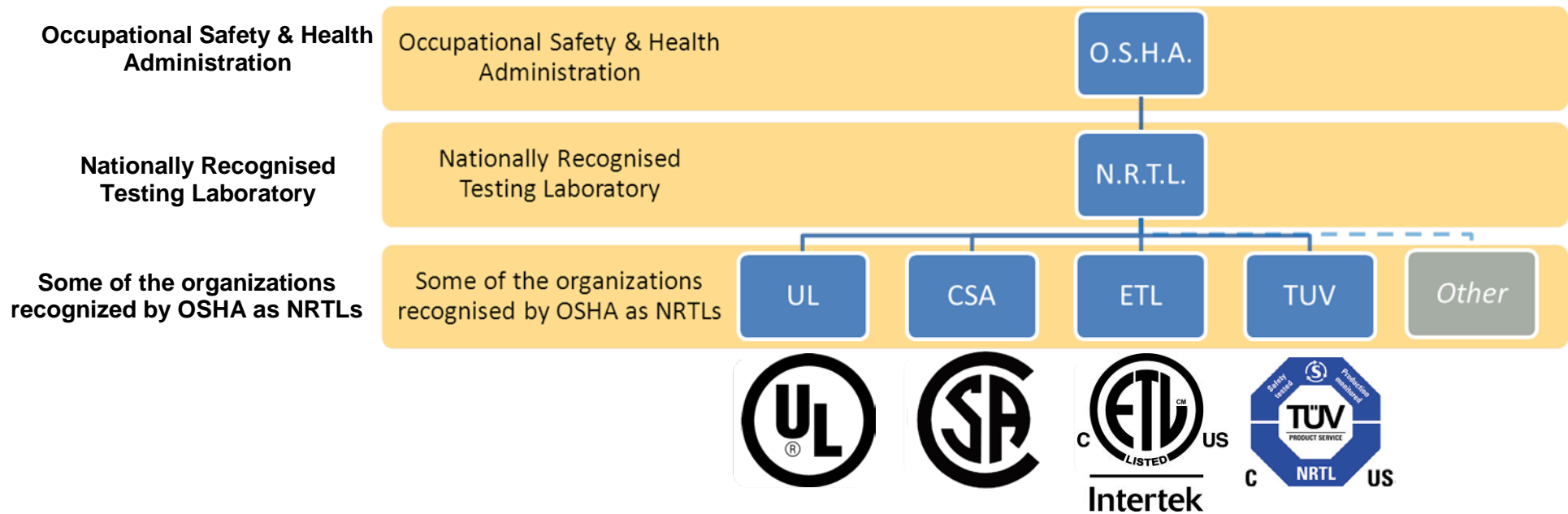

This product has been approved by Intertek Testing and Certification Ltd (ETL) to American Standard UL508C, Standard for Safety, Power Conversion Equipment.

C-25 Compliance

CANADIAN COMPLIANCE

This product has been approved by Intertek Testing and Certification Ltd (ETL) to Canadian Standard CSA 22.2 No. 14, Standard for Industrial Control Equipment and Canadian Standard CSA 22.2 No. 14, Industrial control Equipment.

NORTH AMERICAN AND CANADIAN COMPLIANCE INFORMATION

Motor Base Frequency

PMAC and Induction motor modes are identical.

Drive Switching Frequency (kHz)	Maximum Output Frequency (Hz)
4	500
8	1000
12	1500
16	1500

Drive Protection

Branch Circuit Protection

It is recommended that UL Listed non-renewable cartridge fuses (JDDZ) or UL Listed renewable cartridge fuses (JDRX) are installed upstream of the drive. Refer to Appendix F: "Technical Specifications" - Power Details for recommended fuse ratings.

Solid-State Motor Overload Protection

This product provides Class 10 motor overload protection. The maximum internal overload protection level (current limit) is 180% for 3 seconds, in addition Heavy Duty mode is 150% for 60 seconds and Normal Duty mode is 110% for 60s in. Refer to Appendix D Programming – **Current Limit** for user current limit adjustment information.

An external motor overload protective device must be provided by the installer where the motor has a full-load Ampere rating of less than 50% of the drive output rating or when the **Disable Stall** trip is enabled; or when the **Stall time** parameter is increased above 480 seconds (refer to Appendix D Programming : **Stall Trip**).

Motor over temperature sensing is not provided by the product unless the external temperature sensor is connected to the motor thermistor input on the GPIO option. When the GPIO option is not fitted an external motor over temperature device is required.

Solid-State Short-Circuit Protection

These devices are provided with integral Solid-State Short-Circuit (output) Protection. Branch circuit protection must be provided in accordance with the latest edition of the National Electrical Code NEC/NFPA-70.

The following drives when fitted with UL Listed fuses are suitable for use on a circuit capable of delivering not more than:

Frame D: 5,000 RMS Symmetrical Amperes, 480V maximum

Frame E: 5,000 RMS Symmetrical Amperes, 480V maximum

Frame F: 5,000 RMS Symmetrical Amperes, 480V maximum

When fitted with UL listed, Ferraz Shawmut / Merson, Class J, Type AJT fuses, frame D, E and F sizes may be used on a supply rating delivering not more than 100,000 RMS Symmetrical amperes, 480V maximum.

When group installed with the specified line reactor frame D, E and F sizes may be used on a supply rating delivering not more than 50,000 RMS Symmetrical amperes, 480V maximum. Refer to Appendix F: "Technical Specifications" – Supply short circuit rating.

Field Wiring Temperature Rating

Use minimum 75°C Copper conductors.

Listed Accessories / Options

- Control Module (AC30V Series)
- Graphical Key pad (GKP)
- Profibus DP-V1
- PROFINET IO
- Modbus RTU
- DeviceNet
- CANopen
- EtherNet IP
- General Purpose I/O (GPIO) x 3
- Earth bracket kit for C2 filtering

Recommended Wire Sizes

North American wire sizes (AWG) are based on NEC/NFPA-70 for ampacities of thermoplastic-insulated (75°C) copper conductors.

C-27 Compliance

The wire sizes allow for an ampacity of 125% of the rated input and output amperes for motor branch-circuit conductors as specified in NEC/NFPA-70.

FRAME D Terminal acceptance range: 30-10 AWG				
	Model Number	Power Input AWG	Power Output AWG	Brake Output / DC AWG
400V Build Variant: 380-480V ±10%				
NORMAL DUTY	31V-4D0004-..	14	14	14
	31V-4D0005-..	14	14	14
	31V-4D0006-..	14	14	14
	31V-4D0008-..	14	14	14
	31V-4D0010-..	14	14	14
	31V-4D0012-..	14	14	14
HEAVY DUTY	31V-4D0004-..	14	14	14
	31V-4D0005-..	14	14	14
	31V-4D0006-..	14	14	14
	31V-4D0008-..	14	14	14
	31V-4D0010-..	14	14	14
	31V-4D0012-..	14	14	14

FRAME E Terminal acceptance range: 30-10 AWG				
	Model Number	Power Input AWG	Power Output AWG	Brake Output / DC AWG
400V Build Variant: 380-480V ±10%				
NORMAL DUTY	31V-4E0016-..	12	12	14
	31V-4E0023-..	10	10	14
HEAVY DUTY	31V-4E0016-..	14	14	14
	31V-4E0023-..	12	12	14

FRAME F Terminal acceptance range: 18-6 AWG				
	Model Number	Power Input AWG	Power Output AWG	Brake Output / DC AWG
400V Build Variant: 380-480V ±10%				
NORMAL DUTY	31V-4F0032-..	8	8	12
	31V-4F0038-..	8	8	10
HEAVY DUTY	31V-4F0032-..	10	10	12
	31V-4F0038-..	8	8	10

Environmental

RESTRICTION, EVALUATION, AUTHORISATION AND RESTRICTION OF CHEMICALS (REACH)

The Regulation (EC) No 1907/2006 of the European Parliament and of the Council of 18 December 2006 concerning the Registration, Evaluation, Authorization, and Restriction of Chemicals (REACH) entered into force on June 1, 2007. Parker agrees with the purpose of REACH which is to ensure a high level of protection of human health and the environment. Parker is compliant with all applicable requirements of REACH.

The registration requirements do not apply to Parker since it is neither a manufacturer nor an importer of preparations into Europe.

However, product (article) manufacturers or importers into Europe are obligated under Article 33 of REACH to inform recipients of any articles that contain chemicals on the Substances of Very High Concern (SVHC) candidate list above a 0.1% concentration (by weight per article). As of 19th December 2011 VSD products manufactured and marketed by Parker do not contain substances on the REACH SVHC candidate list in concentrations greater than 0.1% by weight per article. Parker will continue to monitor the developments of the REACH legislation and will communicate with our customers according to the requirement above.

RESTRICTION OF HAZARDOUS SUBSTANCES (RoHS)

This product is in full compliance with RoHS Directive 2011/65/EU, with respect to the following substances:

- 1) Lead (Pb),
- 2) Mercury (Hg),
- 3) Cadmium (Cd),
- 4) Hexavalent chromium (Cr (VI)),
- 5) Polybrominated biphenyls (PBB),
- 6) Polybrominated diphenyl ethers (PBDE).

C-29 Compliance

WASTE ELECTRICAL AND ELECTRONIC EQUIPMENT (WEEE)



Waste Electrical and Electronic Equipment - must not be disposed of with domestic waste.

It must be separately collected according to local legislation and applicable laws.



Parker Hannifin Company, together with local distributors and in accordance with EU directive 2002/96/EC, undertakes to withdraw and dispose of its products, fully respecting environmental considerations.

For more information about how to recycle your Parker supplied waste equipment, please contact your local Parker Service Centre.

Packaging

During transport our products are protected by suitable packaging. This is entirely environmentally compatible and should be taken for central disposal as secondary raw material.

AC31V FRAME D, E AND F VARIABLE SPEED DRIVES**MANUFACTURERS EC DECLARATIONS OF CONFORMITY**

Date CE marked first applied: 01/10/12

EMC Directive	Low Voltage Directive	Machinery Directive
<p>In accordance with the EC Directive 2004/108/EC</p> <p>We Parker Hannifin Manufacturing Limited, address as below, declare under our sole responsibility that the above Electronic Products when installed and operated with reference to the instructions in the Product Manual (provided with each piece of equipment) is in accordance with the relevant clauses from the following standards:-</p> <p>EN 61800-3 (2004)(+A1:2012)</p> <p><i>Note: Filtered versions</i></p>	<p>In accordance with the EC Directive 2006/95/EC</p> <p>We Parker Hannifin Manufacturing Limited, address as below, declare under our sole responsibility that the above Electronic Products when installed and operated with reference to the instructions in the Product Manual (provided with each piece of equipment), is in accordance with the following standard :-</p> <p>EN 61800-5-1 (2007)</p>	<p>In accordance with the EC Directive 2006/42/EC</p> <p>We Parker Hannifin Manufacturing Limited, address as below, declare under our sole responsibility that the above Electronic Products when installed and operated with reference to the instructions in the Product Manual (provided with each piece of equipment), is in accordance with the following standards :-</p> <p>EN 61800-5-2 (2007) Safe Torque Off (STO) EN ISO 13849-1 (2008) PLe/SIL3</p>

MANUFACTURERS DECLARATIONS OF CONFORMITY

EMC DECLARATION	Low Voltage and MACHINERY DIRECTIVES
<p>We Parker Hannifin Manufacturing Limited, address as below, declare under our sole responsibility that the above Electronic Products when installed and operated with reference to the instructions in the Product Manual (provided with each piece of equipment) is in accordance with the relevant clauses from the following standards:-</p> <p>BSEN61800-3 (2004)(+A1:2012)</p> <p><i>Notes:</i></p> <p>i. <i>Non-filtered versions</i> ii. <i>This is provided to aid justification for EMC Compliance when the unit is used as a component.</i></p>	<p>The above Electronic Products are components to be incorporated into machinery and may not be operated alone.</p> <p>The complete machinery or installation using this equipment may only be put into service when all safety considerations of the Directive 2006/42/EC are fully implemented.</p> <p>Particular reference should be made to EN60204-1 (Safety of Machinery - Electrical Equipment of Machines).</p> <p>All instructions, warnings and safety information of the Product Manual must be implemented.</p>

Mr. Jonathan McCormick (UK Quality Assurance & Compliance Manager)

Parker Hannifin Manufacturing Limited, Automation Group, SSD Drives Europe,

NEW COURTWICK LANE, LITTLEHAMPTON, WEST SUSSEX BN17 7RZ

TELEPHONE: +44 (0) 1903 737000, FAX: +44 (0)1903 737100

Registered Number 4806503 England. Registered Office: 55 Maylands Avenue, Hemel Hempstead, Herts HP2 4SJ

AC31V FRAME D, E AND F VARIABLE SPEED DRIVES



MANUFACTURERS EC DECLARATIONS OF CONFORMITY

Date CE marked first applied: 01/10/12

Restriction of Hazardous Substances (RoHS)

We Parker Hannifin Manufacturing Limited, address as below, declare under our sole responsibility that the above Electronic Products comply with the RoHS substance restrictions in EC Directive 2011/65/EU.

Products are produced in accordance with the relevant clauses of the harmonized standard EN50581:2012

"Technical documentation for the evaluation of electrical and electronic products with respect to restriction of hazardous substances".

Mr. Jonathan McCormick (UK Quality Assurance & Compliance Manager)

Parker Hannifin Manufacturing Limited, Automation Group, SSD Drives Europe,

NEW COURTWICK LANE, LITTLEHAMPTON, WEST SUSSEX BN17 7RZ

TELEPHONE: +44 (0) 1903 737000, FAX: +44 (0) 1903 737100

Registered Number 4806503 England. Registered Office: 55 +Maylands Avenue, Hemel Hempstead, Herts HP2 4SJ

Appendix D: **Parameter Reference**

Parameter Descriptions

The parameter descriptions in this section are arranged alphabetically; however, they are also listed below by Category. Expert view level must be selected to see all the parameters listed under the Parameters menu.

	Page		Page		Page
Motor Control		Voltage Control	D-98	Trips	
Autotune	D-2	Speed Ref	D-89	Trips Status	D-97
Braking	D-6	Inputs And Outputs		Trips History	D-96
Control Mode	D-10	Configure	D-34	Stall Trip	D-93
Current Limit	D-12	Values	D-36	VDC Ripple	
Energy Meter	D-16	Option IO		Keypad	
Feedbacks	D-21	General Purpose IO	D-29	Graphical Keypad	D-30
Fluxing VHz	D-23	IO Option Common	D-35	Local Control	D-38
Flycatching	D-27	Base Comms		Application	
Induction Motor Data	D-32	Ethernet	D-18	Macro	D-38
Inj Braking	D-33	Modbus	D-40	Skip Frequencies	D-78
Motor Load	D-43	Web Server	D-99	Minimum Speed	D-39
Motor Nameplate	D-46	Option Comms		Preset Speeds	D-61
Pattern Generator	D-48	BACnet IP	D-4	Raise Lower	D-65
PMAC Flycatching	D-51	CANopen	D-7	PID	D-49
PMAC Motor Data	D-52	Comms	D-8	Device Manager	
PMAC SVC	D-54	ControlNet	D-11	Device State	D-14
Ramp	D-67	DeviceNet	D-14	Device Commands	D-13
Scale Setpoint	D-74	EtherCAT	D-17	Drive info	D-14
Sequencing	D-75	EtherNet IP	D-19	Setup Wizard	D-77
Slew Rate	D-81	Event	D-20	Real Time Clock	D-73
Slip Compensation	D-82	Modbus RTU	D-41	SD Card	D-74
Spd Direct Input	D-84	Modbus TCP	D-42	Soft Menus	D-83
Spd Loop Diagnosis	D-85	Option Ethernet	D-47		
Spd Loop Settings	D-86	Profibus	D-61		
Stabilisation	D-89	Profinet IO	D-64		
Stack Inv Time	D-91	Read Process	D-72		
Torque Limit	D-94	Write Process	D-100		

For details about parameter limits and other attributes refer to the Parameter Table at the end of this appendix. The Parameter Number, (PNO), provided next to each parameter description may be used to quickly find an entry in the Parameter Table at the end of this Appendix by clicking on the link.

D-2 Parameter Reference

Autotune

Advanced Setup::Motor::Autotune

Parameters::Motor Control::Autotune

The autotune is an automatic test sequence performed by the Drive to identify motor model parameters. The motor model is used by the Vector control modes. You **MUST** perform an autotune before operating the Drive in the Vector control mode. Whether the drive is in Vector Control mode or in Open Loop mode is determined by the parameter 015 Control Strategy in menu Control Mode (see page D-10).

PNO Parameter Descriptions

0255 **Autotune Enable**

Puts the autotune module into a state where it will carry out the autotune when the drive is started.

0256 **Autotune Mode**

Selects whether the autotune is carried out on a rotating motor, or whether it just calculates from nameplate data (not the preferred method). It may be necessary to carry out a stationary autotune if the motor is not free to rotate, for example if it is already connected to a machine. Leakage inductance (to tune the current loop) and stator resistance may be measured when the motor is stationary, but other parameters can only be inferred from nameplate data. Use the rotating autotune where possible.

Enumerated Value : Mode

0 : STATIONARY

1 : ROTATING

0257 **Autotune Test Disable**

Allows selected tests to be disabled (default all tests are carried out).
Each test can be individually disabled by setting to TRUE.

Bitfield Value : Test

0 : STATOR RES

1 : LEAKAGE IND

3 : MAG CURRENT

4 : ROTOR TIME CONST

Functional Description

IMPORTANT *You MUST carry out an Autotune if you intend to use the drive in vector control mode. If you are using it in Volts/Hz control an Autotune is not necessary.*

Autotune can only be initiated from the “stopped” condition. When the test is complete, the stack is disabled and Autotune Enable is set to FALSE.

Note Refer to the Chapter 9: Setup Wizard for details on how to perform an Autotune.

Standard Autotune

The **Standard Autotune** feature only works for induction motors (not PMAC motors).

Parameter	Description	Note
MAG CURRENT	Magnetising current	Not measured by Stationary Autotune
STATOR RES	Per phase stator resistance	
LEAKAGE INDUC	Per phase stator leakage inductance	
MUTUAL INDUC	Per phase mutual inductance	
ROTOR TIME CONST	Rotor time constant	This will be identified while the motor is spinning, while measuring the magnetising current. If stationary autotune is selected, it will be identified from magnetising current and motor nameplate rpm

- ◆ The Stationary autotune sequence does not rotate the motor and requires the correct value of MAG CURRENT to be entered.
- ◆ The Rotating autotune sequence rotates the motor up to the user-programmed MAX SPEED (**Scale Setpoint** function) in order to identify these parameters. (A rotating autotune is required if the motor is to be operated above base speed).

D-4 Parameter Reference

BACnet IP

***Advanced Setup::Communications::Option:: BACnet IP
Parameters::Option Comms::Comms:: BACnet IP***

Refer to BACnet IP Technical Manual HA501939U001

BACnet MSTP

***Advanced Setup::Communications::Option:: BACnet MSTP
Parameters::Option Comms::Comms:: BACnet MSTP***

Refer to BACnet MSTP Technical Manual HA501940U001

D-6 Parameter Reference

Braking

Parameters::Motor Control::Braking

The braking function controls the rate at which energy from a regenerating motor is dumped into a resistive load. This dumping prevents the dc link voltage reaching levels which would cause an Overvoltage trip.

PNO Parameter Descriptions

0249 **Braking Enable**

Enables operation of the dynamic braking feature.

0251 **Brake Resistance**

The value of the dynamic braking load resistance.

0252 **Brake Rated Power**

The power that the load resistance may continually dissipate.

0253 **Brake Overrating**

Multiplier that may be applied to **Brake Power** for power overloads lasting no more than 1 second.

0254 **Braking Active**

A read-only parameter indicating the state of the brake switch.

Functional Description

When enabled, the **Braking** feature monitors the internal dc link voltage every milli-second and sets the state of the brake switch accordingly.

The **Braking** feature provides a control signal that is used by the **Slew Rate** limit feature. This causes the setpoint to be temporarily frozen whenever the brake is operating because the dc link voltage exceeds the internal comparison level. This allows the stop rate to be automatically tuned to the characteristics of the load, motor, Drive and brake resistor.

The **Braking** feature operates even when the motor output is not enabled. This allows the function to continually monitor the energy dumped into the braking resistor, and the energy dissipated across the brake switch. With this information the Drive is able to deduce the loading on the brake resistor. Optional trips may be enabled should the switch or resistor be loaded beyond its capabilities.

The "Brake Resistor" and "Brake Switch" trips are disabled by default. To enable these trips, refer to **Trips Status** page D-97. When using braking, the brake resistor information must be entered and these two trips enabled.

CANopen

Parameters::Option Comms::CANopen

Refer to CANopen Technical Manual HA501841U001

D-8 Parameter Reference

CC Link

Parameters::Option Comms::Comms::CC Link

AdvancesSetup::Communications::Option:CC Link

Refer to CC Link Technical Manual HA501941U001

Comms***Parameters::Option Comms::Comms******AdvancesSetup::Communications:Option::Comms***

Refer to any of the following Technical Manuals:

Product Code	Description	Part Number
7003-PB-00	Profibus DP-V1	HA501837U001
7003-PN-00	PROFINET IO	HA501838U001
7003-DN-00	DeviceNet	HA501840U001
7003-CN-00	ControlNet	HA501936U001
7003-CB-00	CANopen	HA501841U001
7003-IP-00	EtherNet IP	HA501842U001
7003-EC-00	EtherCAT	HA501938U001
7003-BP-00	BACnet IP	HA501939U001
7003-BN-00	BACnet MSTP	HA501940U001
7003-RS-00	Modbus RTU	HA501839U001
7003-IM-00	Modbus TCP	HA501937U001
7003-CC-00	CC-LINK	HA501941U001

D-10 Parameter Reference

Control Mode

Advanced Setup::Motor::Control & Type::ControlMode
Parameters::Motor Control::Control Mode::Control Mode

The control mode block provides the means for selecting the type of motor and the desired method of controlling the motor.

PNO Parameter Descriptions

0511 Motor Type

Motor type selection parameter
Allows the user to select the type of motor.

Enumerated Value : Motor Type
0 : INDUCTION MOTOR
1 : PMAC (PERMANENT MAGNET) MOTOR

0512 Control Strategy

Select control strategy selection parameter.
Allows the user to select the method of controlling the motor.

Enumerated Value : Motor Type
0 : VOLTS HERTZ CONTROL
1 : VECTOR CONTROL

Functional Description

The motor selection is the first step in setting the control mode.

The selection of control strategy comes next, with the permitted settings as follows:

- Induction motors can be run in either volts hertz mode or vector mode
- Permanent magnet motors can only be run in vector control mode

ControlNet

***Advanced Setup::Communications::Option::ControlNet
Parameters::Option Comms::Comms::ControlNet***

Refer to ControlNet Technical Manual HA501936U001

D-12 Parameter Reference

Current Limit

Parameters::Motor Control::Current Limit

Designed for all Motor Control Modes

This function allows you to set the maximum level of motor rated current (as a % of the user-set **Motor Current**) which is allowed to flow before current limit action occurs. If the measured motor current exceeds the current limit value with a motoring load, the motor speed is reduced to control the excess load. If the measured motor current exceeds the current limit value with a regenerating load, the motor speed is increased up to a maximum of **100% Speed in RPM (Scale Setpoint)**.

The maximum value of current limit for a particular motor is limited by the AC30V current rating.

If a motor of larger rating than the AC30V is connected, then the current limit max value is limited by the AC30V current rating.

If a motor of lower rating than the AC30V is connected, then the current limit max value is limited to 300% (if compatible with the AC30V current rating) for an induction motor (IM) and to the ratio **PMAC Max Current** to **PMAC Rated Current** for a PMAC motor.

% are always expressed as % of the user set **Motor Current** (rated current of PMAC or IM Motor).

PNO Parameter Descriptions

0305 Current Limit

This parameter sets the level of motor current, as a % of **Motor Current** (refer to the relevant MOTOR definition (PMAC or IM function) at which the Drive begins to take current limit action.

0307 Regen Limit Enable

This parameter enables or disables regenerative current limit action.

Note that this parameter only works in open-loop VOLTS / Hz motor control mode.

Functional Description

Internal limit : output of the Stack Inv Time module + reduction as a function of electrical low speed (< 3Hz) and as function of heatsink temperature

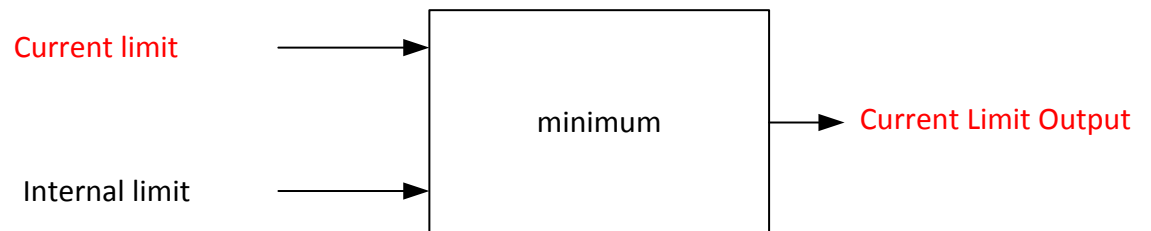

Device Commands**Update Firmware****Parameters::Device Manager::Device Commands****PNO Parameter Descriptions**1002 **Update Firmware**

This parameter is only visible when an SD card with a firmware update file is inserted into the drive. Changing this parameter to TRUE will start the firmware update procedure.

Following a firmware update it is advisable to power re-run the Setup Wizard, D-77.

1001 **Save All Parameters**

When a parameter is modified via the GKP or via the built-in web page the parameter value is saved automatically. When a parameter is modified via another source, (for example via the Modbus TCP/IP communications protocol), the value will not be saved automatically. In this case a save may be instigated by changing this parameter from FALSE to TRUE.

D-14 Parameter Reference

DeviceNet

***Advanced Setup::Communications::Option::DeviceNet
Parameters::Option Comms::Comms::DeviceNet***

Refer to DeviceNet Technical Manual HA501840U001

Drive info**Advanced Setup::Environment
Parameters::Device Manager::Drive info**

PNO	Parameter Descriptions
<u>0961</u>	Drive Name A string value that may be used to identify this drive in a system.
<u>1100</u>	Firmware Version The version of the firmware running in the Control Module.
<u>1109</u>	Stack Pcode The product code string that may be used to order an equivalent Power Stack.
<u>1258</u>	Stack Serial No The serial number of the Power Control Card, (part of the Power Stack assembly).
<u>1116</u>	Control Module Pcode The product code string that may be used to order an equivalent Control Module, excluding options.
<u>0977</u>	Control Module Serial The serial number of the Control Module.
<u>1121</u>	Comms Option Pcode The product code string that may be used to order an equivalent Communications Option, (only visible when a Communications Option is selected).
<u>1129</u>	Comms Option Serial The serial number of the fitted Communications Option, (only visible when a Communications Option is selected).
<u>1125</u>	IO Option Pcode The product code string that may be used to order an equivalent IO Option, (only visible when an IO Option is selected).
<u>1134</u>	IO Option Serial No The serial number of the fitted IO Option, (only visible when an IO Option is selected).

D-16 Parameter Reference

Energy Meter

Advanced Monitor::Energy Meter

Parameters::Motor Control::Energy Meter

This feature measures the electrical energy used by the motor.

PNO	Parameter Descriptions
<u>0380</u>	Power kW This diagnostic shows the power being delivered to the load in kilowatts.
<u>0381</u>	Power HP This diagnostic shows the power being delivered to the load in horsepower.
<u>0382</u>	Reactive Power This diagnostic shows the reactive power being delivered to the load in kilo volt-amperes reactive.
<u>0383</u>	Energy kWhr This diagnostic shows the total energy consumed by the load in kilowatt hours.
<u>0385</u>	Power Factor Est This diagnostic shows the power factor estimate (between 0 and 1).
<u>0386</u>	Power Factor Angle Est This diagnostic shows the power factor angle estimate.
<u>0389</u>	Reset Energy Meter When Reset Energy Meter is set to TRUE, the Energy kWhr parameter is reset to zero automatically when the maximum value is reached. When Reset Energy Meter is set to FALSE, the Energy kWhr parameter is held at the maximum value when the maximum value has been reached Changing this from FALSE to TRUE at anytime will cause the Energy kWhr parameter to be reset to zero.

EtherCAT

***Advanced Monitor::Communications::Option::EtherCAT
Parameters::Option Comms::Comms::EtherCAT***

Refer to EtherCAT Technical Manual HA501938U001

D-18 Parameter Reference

Ethernet

***Advanced Monitor::Communications::Option::Ethernet
Parameters::Option Comms::Comms::Ethernet***

Refer to Chapter 12 Ethernet

EtherNet IP

***Advanced Monitor::Communications::Option::Ethernet IP
Parameters::Option Comms::Comms::Ethernet IP***

Refer to EtherNet IP Technical Manual HA501842U001

D-20 Parameter Reference

Event

Advanced Monitor::Communications::Option::Event Parameters::Option Comms::Event

Refer to any of the following Technical Manuals:

Product Code	Description	Part Number
7003-PB-00	Profibus DP-V1	HA501837U001
7003-PN-00	PROFINET IO	HA501838U001
7003-DN-00	DeviceNet	HA501840U001
7003-CN-00	ControlNet	HA501936U001
7003-CB-00	CANopen	HA501841U001
7003-IP-00	EtherNet IP	HA501842U001
7003-EC-00	EtherCAT	HA501938U001
7003-BP-00	BACnet IP	HA501939U001
7003-BN-00	BACnet MSTP	HA501940U001
7003-RS-00	Modbus RTU	HA501839U001
7003-IM-00	Modbus TCP	HA501937U001
7003-CC-00	CC-LINK	HA501941U001

Feedbacks

Commissioning::All Parameters::Motor Control::Feedbacks

The **Feedbacks** feature allows you to view speed feedback and motor current related diagnostics.

PNO Parameter Descriptions

0390 Duty Selection

When selected, selects **Heavy Duty** allowing higher continuous ratings with less overload capability (typically 150%, 60s).

When not selected, selects **Normal Duty** duty (typically 110%, 60s).

% are related to the Drive/stack ratings.

0392 DC Link Voltage

This shows the voltage across the dc link capacitors.

0393 Actual Speed RPM

This parameter changes according to the **Control Mode**:

- In **Sensorless Vec** mode the parameter shows the calculated mechanical speed of the motor shaft in revolutions per minute.
- In **Volts/Hz** mode the parameter shows motor synchronous speed in rpm.

0394 Actual Speed Hz

This parameter changes according to the **Control Mode**:

- In **Sensorless Vec** mode the parameter shows the calculated mechanical speed of the motor shaft in hertz.
- In **Volts/Hz** mode, the parameter shows the motor synchronous speed hertz.

0395 Actual Speed Percent

This parameter changes according to the **Control Mode**:

- In **Sensorless Vec** mode the parameter shows the calculated mechanical speed of the motor shaft as a percentage of the user maximum speed setting (**Max Speed** in the **Reference** function).
- In **Volts/Hz** mode, the parameter shows the electrical drive output frequency as a percentage of the user maximum speed setting (**Max Speed** in the **Reference** function).

0398 Iq

Current in the torque axis (Vector Control)

D-22 Parameter Reference

PNO	Parameter Descriptions
<u>0399</u>	Actual Torque Calculated torque, based on the Iq current.
<u>0400</u>	Actual Field Current Calculated field, based on the Id current.
<u>0401</u>	Motor Current Percent This diagnostic shows the level of rms line current being drawn from the drive as a percentage of the rated current of the relevant motor definition.
<u>0402</u>	Motor Current This diagnostic shows the level of rms line current in Amps being drawn from the Drive.
<u>0403</u>	100% Stack Current Amps This diagnostic indicates the stack rating in Amps. This reduces as a function of pwm switching frequency.
<u>0404</u>	Stack Current (%) Stack current percentage.
<u>0405</u>	Motor Terminal Volts Volts between motor phases in Vrms.
<u>0406</u>	Processor Temperature Ambient temperature of Control Module.
<u>0407</u>	Heatsink Temperature This diagnostic displays the power stack heatsink temperature in °Centigrade.
<u>0408</u>	Electrical Rotor Speed Electrical rotor speed in electrical hertz.
<u>0409</u>	Heatsink OT Trip Heatsink Overtemp Trip Level.
<u>0410</u>	Heatsink OT Warning Heatsink Overtemp Warning level.
<u>0411</u>	Heatsink Hot Warning Define Heatsink Hot Warning Level.

Fluxing VHz

Parameters::Motor Control::Fluxing VHz

Designed for VOLTS/Hz motor Control Mode.

This function allows user parameterisation of the conventional (volts/hertz) fluxing strategy of the Drive. This is achieved through three flexible Volts-to-frequency templates. Starting torque performance can also be tailored through the **Fixed Boost**, **Accelrtn Boost** and **Auto Boost** parameters.

PNO Parameter Descriptions

0422 VHz Shape

Type of volts to frequency template to flux the motor. The choices for this parameter are:

Enumerated Value : V/F Shape

0 : LINEAR LAW

1 : FAN LAW

2 : USER DEFINED

This gives a constant flux characteristic up to the **Base Frequency** (see **Motor Nameplate** function).

This gives a quadratic flux characteristic up to the **Base Frequency**. This matches the load requirement for fan and most pump applications

This gives a user defined flux characteristic up to the **Base Frequency**.

V/F SHAPE

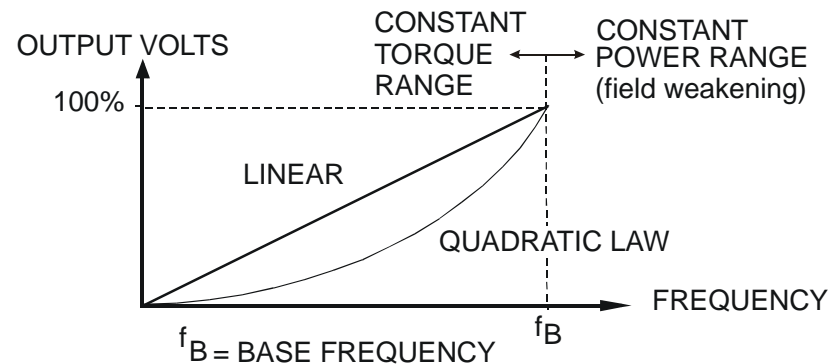

D-24 Parameter Reference

PNO Parameter Descriptions

0447 Fixed Boost

This parameter allows for no-load stator resistance voltage drop compensation. This correctly fluxes the motor (under no-load conditions) at low output frequencies, thereby increasing available motor torque. Fixed boost can be set in addition to auto boost and acceleration boost.

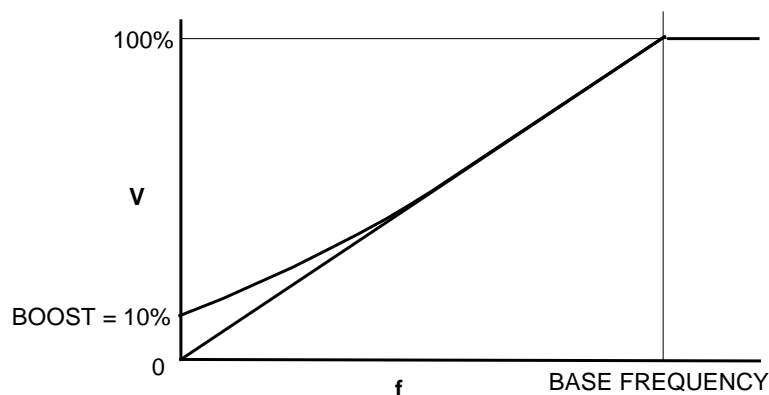

0448 Auto Boost

This parameter allows for load dependent stator resistance voltage drop compensation. This correctly fluxes the motor (under load conditions) at low output frequencies, thereby increasing available motor torque. **Auto Boost** can be set in addition to **Fixed Boost**.

The value of the **Auto Boost** parameter determines level of additional volts supplied to the motor for 100% load.

Setting the value of auto boost too high can cause the Drive to enter current limit. If this occurs, the Drive will be unable to ramp up in speed. Reducing the value of auto boost will eliminate this problem.

0450 Acceleration Boost

Additional amount of fixed boost when the drive is accelerating.

0451 Energy Saving Enable

Enable/Disable energy saving mode to minimize energy consumption.

0423 VHz User Freq[11]

Array of user defined frequency for V/f control

0435 VHz User Volts[11]

Array of VHz User Volts for V/f control

Functional Description

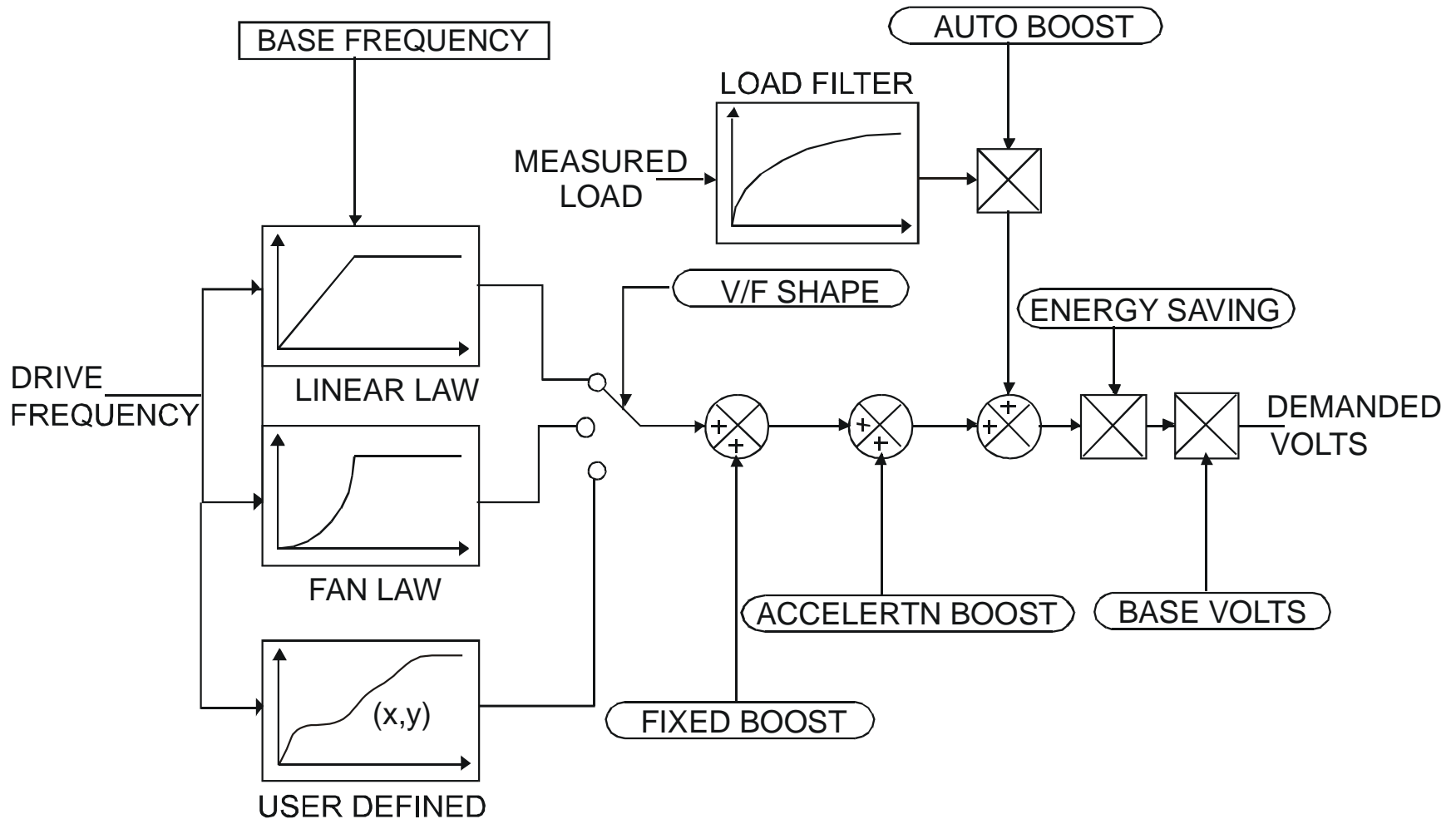

V/F Shape

The function allows the user to parameterise the Drive's conventional V/F motor fluxing scheme. Three V/F shapes are available, LINEAR LAW, FAN LAW and USER DEFINED:

- ◆ Linear Law V/F shape should be used in applications requiring constant motor torque though out the speed range (e.g. machine tools or hoists).

D-26 Parameter Reference

- ◆ Fan Law V/F shape provides extra energy savings for fan or pump applications.
- ◆ User Defined V/F shape provides a method for the user to define any profile. 10 user definable (x,y) points are provided. Linear interpolation is used between each point. The drive also assumes the following points - (0%,0%) and (100%,100%) - though these may be overridden. For example, (USER FREQ 1 = 0%, USER VOLTAGE 1 = 5%) takes precedence over (0%, 0%).

For any of these V/F shapes the **Base Frequency** parameter (in the **Motor Nameplate** function) which is the value of Drive output frequency at which maximum output volts is provided, can be set by the user.

Boost Parameters

- ◆ Correct no-load motor fluxing at low Drive output frequencies can be achieved by setting the **Fixed Boost** parameter.
- ◆ Correct motor fluxing under load conditions is achieved by setting the **Auto Boost** parameter. The motor is correctly fluxed when the **Actual Field Current** diagnostic in the **Feedbacks** function reads 100.0% .
- ◆ Additional **Fixed Boost** can be applied during acceleration by setting the **Accelertrn Boost** parameter. This can be useful for starting heavy/high stiction loads.

Saving Energy

An **Energy Saving** mode is provided which, when enabled under low load conditions in the steady state, attempts to reduce the output voltage so that minimum energy is used.

Flycatching**Parameters::Motor Control::Flycatching**

This feature performs a directional speed search. It allows the Drive to seamlessly catch a spinning motor before controlling the motor to the desired setpoint. This is especially useful for large inertia fan loads, where drafts in building air ducts can cause a fan to 'windmill'.

PNO Parameter Descriptions0310 **VHz Flying Start Enable**

Enable flycatching in V/Hz control mode when TRUE

0311 **VC Flying Start Enable**

Enable flycatching in Vector control mode when TRUE

0312 **Flying Start Mode**

Mode of operation - V/Hz control

0313 **Search Mode**

The type of speed search carried out by the flycatching sequence.

Enumerated Value : Search Mode

0 : BIDIRECTIONAL

1 : UNIDIRECTIONAL

0314 **Search Volts**

The percentage level of the search volts applied to the motor during the speed search phase of the flycatching sequence. Increasing this parameter improves the accuracy of the discovered motor speed but increases the braking influence of the speed search on the rotating motor.

0315 **Search Boost**

The level of search boost applied to the motor during the speed search phase of the flycatching sequence.

0316 **Search Time**

The search rate during the speed search phase of the flycatching sequence. Performing the flycatching speed search too quickly can cause the drive to inaccurately identify the motor speed. Refluxing at an inaccurate motor speed can cause the drive to trip on overvoltage. If this occurs, increasing this parameter will reduce the risk of tripping.

0317 **Min Search Speed**

The lowest search speed before the speed search phase of the flycatching sequence is considered to have failed.

D-28 Parameter Reference

PNO Parameter Descriptions

0318 Flying Reflux Time

The rate of rise of volts from the search level to the working level after a successful speed search. Refluxing the motor too quickly can cause the Drive to trip on either overvoltage or overcurrent. In either case, increasing this parameter will reduce the risk of tripping.

Functional Description

The flycatching function enables the drive to be restarted smoothly into a spinning motor. It applies small search voltages to the motor whilst ramping the Drive frequency from maximum speed to zero. When the motor load goes from motoring to regenerating, the speed search has succeeded and is terminated. If the search frequency falls below the minimum search speed, the speed search has failed and the Drive will ramp to the speed setpoint from zero.

The flycatching sequence can be triggered by different starting conditions:

ALWAYS: All starts (after controlled or uncontrolled stop, or after a power-up)
TRIP or POWER-UP: After uncontrolled stop, i.e. trip or coast, or after a power-up
TRIP: After uncontrolled stop, i.e. trip or coast

The type of speed sequence may be Bi-directional or Unidirectional:

Bi-directional

Initially, the search is performed in the direction of the speed setpoint. If the drive fails to identify the motor speed in this direction, a second speed search is performed in the reverse direction.

Unidirectional

The search is performed only in the direction of the speed setpoint.

General Purpose IO**Advanced Monitor::Inputs and Outputs****Parameters::Option IO::General Purpose IO**

The General Purpose IO parameters configure the use of the three IO Options, (D-35). This group of parameters is only visible when an IO Option is selected.

PNO Parameter Descriptions1181 **Anin 11 Value**

A percentage value in the range -100% to +100% corresponding to an input voltage in the range -10V to +10V.

1182 **Anin 12 Value**

A percentage value in the range -100% to +100% corresponding to an input voltage in the range -10V to +10V.

1183 **Anin 13 Value**

A percentage value in the range -100% to +100% corresponding to an input voltage in the range -10V to +10V.

1184 **Thermistor Type**

Defines the thermistor type. This is used when generating the MOTOR OVERTEMP trip.

- 0 NTC, (Negative Temperature Co-efficient)
- 1 PTC, (Positive Temperature Co-efficient)
- 2 KTY, (a linear temperature measuring device).

1185 **Thermistor Resistance**

The resistance measured across the thermistor terminals.

1004 **Thermistor Trip Level**

Defines the level at which a Motor Over Temperature trip will be generated. The default value is appropriate for PTC and NTC thermistor types.

1187 **RTC Trim**

A trim value that may be used to speed up or slow down the Real Time Clock on the IO option. A positive trim value will cause the RTC to run faster, an negative value causes the RTC to run slower. Refer to the AC30V General Purpose I/O Option manual for more details.

Once programmed, the RTC trim affects the operation of the RTC both in battery backed up mode and normal running mode.

D-30 Parameter Reference

Graphical Keypad

Advanced Setup::Environment

Parameters::Keypad::Graphical Keypad

PNO Parameter Descriptions

1141 **View Level**

The view level may be used as a convenient method to hide menus and parameters not currently required. The view levels are:

- 0 Operator – only the “Control Screen”, “Favourites”, “Setup” and “Monitor” menus are visible.
- 1 Technician – the “Advanced Setup” and “Advanced Monitor” menus are visible in addition to the above
- 2 Engineer – the “Parameters” menu is visible in addition to the above.

0982 **Startup Page**

On power-up the GKP briefly displays the drive name, rating and software version. After a short timeout the display automatically changes to the menu defined here

- 0 Default
- 1 Control Screen
- 2 Favourites
- 3 Monitor

When Startup Page is set to “Default” the first menu will be:

- The “Control Screen” menu if the drive is in local sequencing mode, otherwise
- The “Favourites” menu if the Favourites menu is not empty, otherwise
- The “Monitor” menu.

0983 **Display Timeout**

When the GKP is idle, (no keys pressed), for a period longer than the Display Timeout, the display will automatically revert to the menu defined in the Startup Page parameter.

Setting the Display Timeout to zero defeats this feature.

1142 **GKP Password**

Defines the password to be entered to allow modification to parameters using the GKP. This password does not affect access via the web page. A value of 0000, (the default value), inhibits the password feature. Entering a value other than 0000 causes the GKP to prompt for the password before proceeding to the parameter edit mode.

Once a password has been entered the GKP remains unlocked. To re-lock the password return to the top of the menu tree then press Soft Key 1.

PNO Parameter Descriptions1097 **Password in Favourite**

When the GKP Password is active this parameter may be used to selectively defeat the password feature in the Favourites menu. By default this parameter is FALSE, meaning that the password is ignored when modifying Favourites parameters.

1098 **Password in Local**

When the GKP Password is active this parameter may be used to selectively defeat the password feature in the Control Screen menu. By default this parameter is FALSE, meaning that the password is ignored when modifying the Local Setpoint and other related parameters.

1143 **Version**

Indicates the firmware version of the attached GKP.

D-32 Parameter Reference

Induction Motor Data

Advanced Setup::Motor::Induction Motor Data

Parameters::Motor Control::Induction Motor Data

Only available if IM MOTOR selected in **Control Mode**

PNO Parameter Descriptions

0568 **Magnetising Current**

The no load current of the induction motor, defined as rotor flux / magnetising inductance, usually given the title "imr".

0569 **Rotor Time Constant**

Induction Motor rotor time constant.

0570 **Leakage Inductance**

Induction motor leakage inductance. Displayed as star or delta equivalent value according to "Per Phase Parameters" setting.

0571 **Stator Resistance**

Induction motor stator resistance. Displayed as star or delta equivalent value according to "Per Phase Parameters" setting.

0572 **Mutual Inductance**

Induction motor mutual inductance. Displayed as star or delta equivalent value according to "Per Phase Parameters" setting.

Inj Braking**Parameters::Motor Control::Inj Braking**

Designed for VOLTS/Hz Motor Control Mode.

The injection braking feature provides a method of stopping spinning induction motors without returning the kinetic energy of the motor and load back in to the dc link of the Drive. This is achieved by running the motor highly inefficiently so that all the energy stored in the load is dissipated in the motor. Thus, high inertia loads can be stopped without the need for an external dynamic braking resistor.

PNO	Parameter Descriptions
<u>0324</u>	DC Inj Deflux Time Motor defluxed duration before starting injection braking
<u>0325</u>	DC Inj Frequency Max frequency applied to the motor
<u>0326</u>	DC Inj Current Limit Motor current value
<u>0327</u>	DC Pulse Time Duration of dc pulse for motor speed below 20% of base speed
<u>0328</u>	Final DC Pulse Time Duration of the final dc holding pulse
<u>0329</u>	DC Current Level Level of dc pulse applied
<u>0330</u>	DC Inj Timeout Maximum time in the low frequency injection braking state
<u>0331</u>	DC Inj Base Volts Maximum volts applied at base speed

D-34 Parameter Reference

IO Configure

Advanced Setup::Inputs and Outputs

Parameters::Inputs And Outputs::IO Configure

These parameters are used to configure the input signal processing.

PNO Parameter Descriptions

0001 **Anin 01 Type**

Analog input 1 is associated with terminal X11.1

The signal processing electronics for analog input 1 supports four input ranges:

0. -10..10V
1. 0..10V
2. 0..20MA
3. 4..20MA

0002 **Anin 02 Type**

Analog input 2 is associated with terminal X11.2

The signal processing electronics for analog input 2 supports two input ranges:

0. -10..10V
1. 0..10V

0003 **Anout 01 Type**

Analog output 1 is associated with terminal X11.3

The signal processing electronics for analog output 1 supports two output ranges:

0. -10..10V
1. 0..10V

0004 **Anout 02 Type**

Analog output 1 is associated with terminal X11.4

The signal processing electronics for analog output 2 supports three output ranges:

1. 0..10V
2. 0..20MA
3. 4..20MA

Functional Description

The values associated with each terminal are shown in the **IO Values** parameter (D-36).

IO Option Common**Parameters::Option IO::IO Option Common****PNO Parameter Descriptions**1178 **IO Option Type**

Defines the type of IO option required by the configuration.

0. NONE
1. GENERAL PURPOSE
2. THERMISTOR
3. RTC AND THERMISTOR

1179 **Actual IO Option**

Indicates the type of IO option that is currently fitted

0. NONE
1. GENERAL PURPOSE
2. THERMISTOR
3. RTC AND THERMISTOR

1180 **IO Option Status**

Indicates the status of the IO option

0. OK
1. OPTION NOT FITTED
2. TYPE MISMATCH
3. TYPE UNKNOWN
4. HARDWARE FAULT

Functional Description

These parameters are used to set and verify the **IO Option** configuration. If the status parameter is not OK then the drive will not enter the Operational state.

Status	Description
OK	The configuration is valid. The status will always be OK if no IO option is required, even if one is fitted. Alternatively, if the IO option fitted is working correctly and supports the required functionality then the status will be OK For example, if the required type is THERMISTOR and the actual type is GENERAL PURPOSE then the status will be OK as the General Purpose option supports the thermistor functionality.
OPTION NOT FITTED	An option was required and none was detected
TYPE MISMATCH	The fitted option does not support the required features
TYPE UNKNOWN	The firmware in the drive does not recognise the fitted option
HARDWARE FAULT	The fitted option is not working as expected.

D-36 Parameter Reference

IO Values

Advanced Monitor::Inputs and Outputs

Parameters::Inputs and Outputs::IO Values

These parameters present the Input and Output values in a form suitable for processing by the application and fieldbus.

PNO Parameter Descriptions

0005 Digin Value

Presents all the digital inputs to the drive as a 16-bit word. The bits within the word may be accessed individually, or the entire word may be accessed as a group.

Bit	Signal name	Terminal	Comment	PNO for individual bit access
0	Digital Input 01	X13.2		0006
1	Digital Input 02	X13.3		0007
2	Digital Input 03	X13.4		0008
3	Digital Input 04	X12.1	Common terminal with digital output 1	0009
4	Digital Input 05	X12.2	Common terminal with digital output 2	0010
5	Digital Input 06	X12.3	Common terminal with digital output 3	0011
6	Digital Input 07	X12.4	Common terminal with digital output 4	0012
7	STO Inactive	X10		0013
8	Digital Input 11		GPIO option	0014
9	Digital Input 12		GPIO option	0015
10	Digital Input 13		GPIO option	0016
11	Digital Input 14		GPIO option	0017
12	Digital Input 15		GPIO option	0018
13	Digital Input 16		GPIO option	0019

0022 Digout Value

Presents all the digital outputs from the drive as a 16-bit word. The bits within the word may be accessed individually, or the entire word may be accessed as a group.

Bit	Signal Name	Terminal	Comment	PNO for individual bit access
0	Digital Output 01	X12.1	Common terminal with digital input 4	0023
1	Digital Output 02	X12.2	Common terminal with digital input 5	0024
2	Digital Output 03	X12.3	Common terminal with digital input 6	0025
3	Digital Output 04	X12.4	Common terminal with digital input 7	0026
4	Relay 01	X14.1&2		0027
5	Relay 02	X14.3&4		0028

PNO Parameter Descriptions

8	Digital Output 11	GPIO option	0031
9	Digital Output 12	GPIO option	0032
10	Digital Output 13	GPIO option	0033
11	Digital Output 14	GPIO option	0034
12	Digital Output 15	GPIO option	0035
13	Digital Output 16	GPIO option	0036
14	Relay 11	GPIO option	0037
15	Relay 12	GPIO option	0038

0039 **Anin 1 Value**

Terminal X11.1

The value returned by the signal processing electronics. For unipolar ranges, (all except -10..10V), the value is expressed as a percentage of the hardware range. For the -10..10V range the full range signal is expressed as -100% to +100%.

0040 **Anin 1 Break**

When the input range is set to 4..20mA a break is defined as an input signal less than 3mA. Otherwise this parameter is set to FALSE.

0041 **Anin 2 Value**

Terminal X11.2

The value returned by the signal processing electronics. For the 0..10V range the value is expressed as a percentage of the hardware range, (0 to 100%). For the -10..10V range the full range signal is expressed as -100% to +100%.

0042 **Anout 1 Value**

Terminal X11.3

The desired output value expressed as a percentage of the output range.

Range	Mapping
0..10V	0% gives 0V, 100% gives 10V
0..20mA	0% gives 0mA, 100% gives 20mA
4..20mA	0% gives 4mA, 100% gives 20mA

0043 **Anout 2 Value**

Terminal X11.4

The desired output value expressed as a percentage of the output range.

Range	Mapping
-10..10V	-100% gives -10V, 100% gives 10V
0..10V	0% gives 0V, 100% gives 10V

D-38 Parameter Reference

Local Control

Parameters::Keypad::Local Control

These parameters configure the use of the GKP keys for local start / stop control of the drive.

PNO Parameter Descriptions

1140 **Run Key Action**

Defines the use of the green start key in local mode.

- 0. RUN
- 1. JOG

When RUN is selected, pressing the green Start key will start the drive using Local Reference as the active setpoint. To stop the drive press the RED Stop key.

When JOG is selected, pressing the green Start key will start the drive running using the Jog Setpoint as the active setpoint. The drive will stop when the key is released.

1253 **Local/Rem Key Active**

Enables the L/R soft key function. This is used to change between Local and Remote sequencing modes from the GKP.

1255 **Local Dir Key Active**

Enables the ability to change the direction from the GKP when running in local sequencing mode. When FALSE the direction will always be positive.

1239 **Local Run Key Active**

Enables the green Start key function when in local sequencing mode. When FALSE the Start key is ignored, (for both RUN and JOG modes).

1240 **Local Direction**

Used to change the direction the motor will rotate when in local sequencing mode.

- 0 Forwards
 - 1 Reverse
-

Minimum Speed

Advanced Setup::Application::Minimum Speed

Function availability depends on macro selected.

The minimum speed function is used to determine how the AC30V will follow a reference. There are two modes:

PNO Parameter Descriptions

1906 Minimum Speed Value

Specifies the minimum output value.

1907 Minimum Speed Mode

There are two modes of operation:

Enumerated Value:

0 : **PROP WITH MINIMUM**

1 : **LINEAR**

Functional Description

There are two operating modes for the **MINIMUM SPEED** function:

PROP WITH MINIMUM (proportional with minimum)

In this mode the **MINIMUM SPEED** function behaves like a simple clamp. The **Minimum Speed Value** has the valid range -100% to 100% and the output is always greater than or equal to the **Minimum Speed Value**.

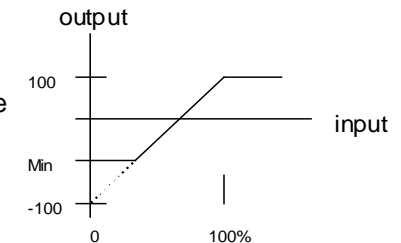

LINEAR

In this mode the **MINIMUM SPEED** function first clamps the input to zero then rescales the input such that the output goes linearly between minimum and 100% for an input that goes from 0 to 100%.

Note the constraints:-

min \geq 0

input \geq 0

max = 100%

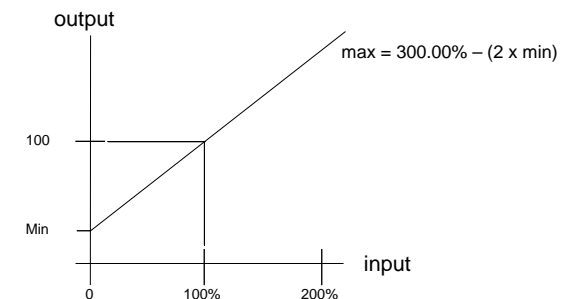

D-40 Parameter Reference

Modbus

Advanced Setup::Communications::Base Modbus

Parameters::Base Comms::Modbus

Refer to Appendix A Modbus TCP

Modbus RTU

Advanced Monitor::Communications::Option

Parameters::Option Comms::Modbus RTU

Refer to Modbus RTU Technical Manual HA501839U001

D-42 Parameter Reference

Modbus TCP

Advanced Setup::Communications::Option

Parameters::Option Comms::Modbus TCP

Refer to Appendix A: Modbus TCP

Motor Load**Parameters::Motor Control::Motor Load**

Motor Protection, function of the motor type.

The **Motor Load** parameters determines the allowed level of motor overload. This can be especially useful when operating with motors smaller than the drive rating.

For an IM, an IxT protection is used and provides a current reduction if the max overload level is reached.

The max overload level is calculated based on a 150% for 60s.

For a PMAC motor, the motor load is calculated using the rated motor current and the thermal time constant (2 parameters of the PMAC motor module). The Thermal time constant is used as the constant time of a simple 1st order low pass filter.

% Are all related to rated motor current.

PNO	Parameter Descriptions
<u>0332</u>	100% Motor Current Motor current in Amps rms corresponding to 100%
<u>0333</u>	Motor Inv Time Overl'd Only available for IM motor Overload % of the motor inverse time protection
<u>0334</u>	Motor Inv Time Delay Only available for IM motor Overload time of the motor inverse time protection from cold state
<u>0335</u>	Motor Inv Time Warning Only available for IM motor Output information. Becomes TRUE when the overload is 5% of the maximum value before reducing the current
<u>0336</u>	Motor Inv Time Active Only available for IM motor Output information. Becomes TRUE when overload reaches 100% of the overload limit

D-44 Parameter Reference

PNO	Parameter Descriptions
<u>0337</u>	Motor Inv Time Output % Only available for IM motor Actual output limit of the inverse time motor protection. This value is compared to the Stack Inv Time current limit output to provide the internal limit to the current limit module.
<u>0338</u>	Motor I2T TC Only available for PMAC motor Time constant of the motor , define in the PMAC Motor Data module
<u>0339</u>	Actual Motor I2T Output Only available for PMAC motor Level of motor load in percent
<u>0340</u>	Motor I2T Active Only available for PMAC motor Level of motor load has reached 105%
<u>0341</u>	Motor I2T Warning Only available for PMAC motor Level of motor load has reached 95%
<u>0342</u>	Motor I2T Enable Only available for PMAC motor Output information : Motor I2T protection is active, overload is higher than 105%

Functional Description

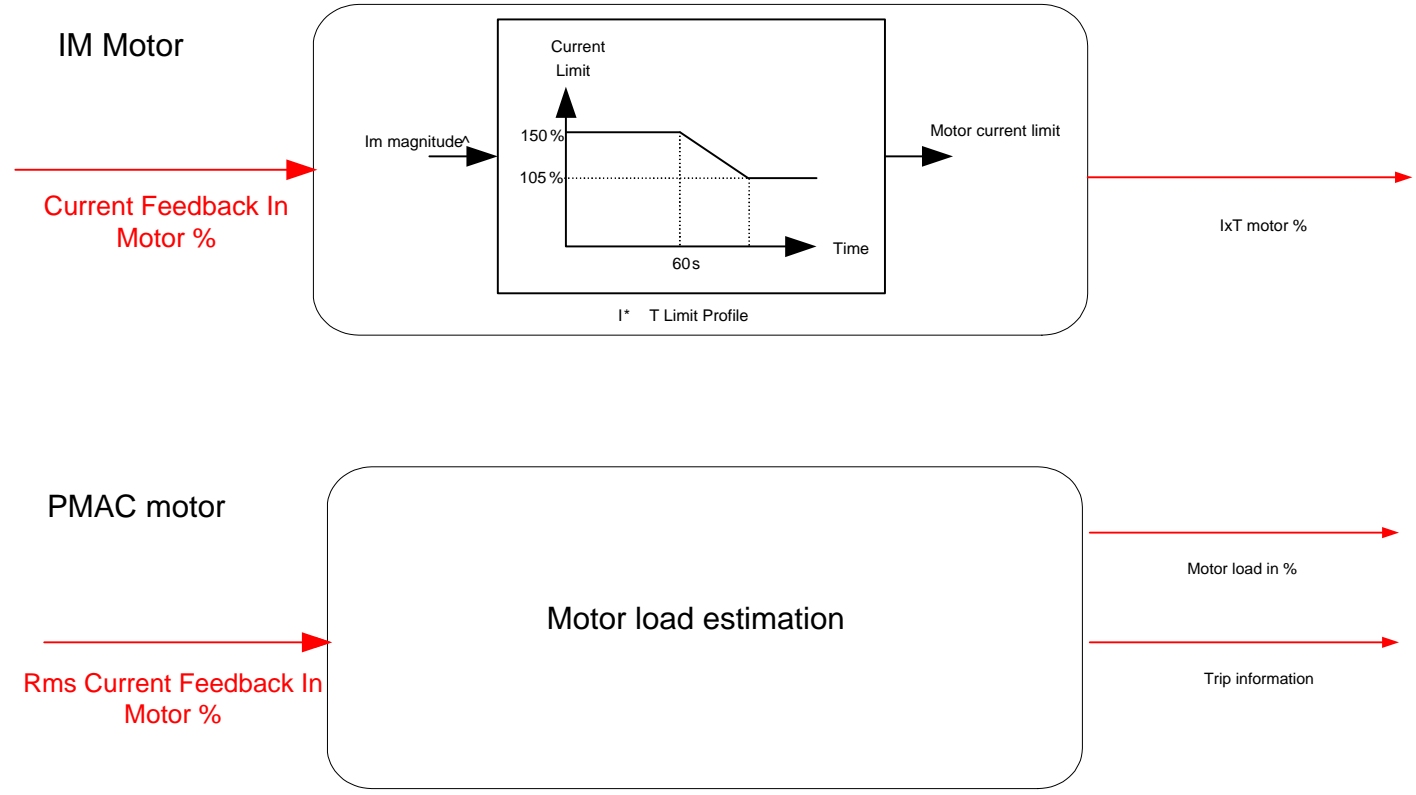

D-46 Parameter Reference

Motor Nameplate

Advanced Setup::Motor::Motor Nameplate

Parameters::Motor Control::Motor Nameplate

Only available if VHz control selected in **Control Mode**.

In this function you enter the details of the motor under control and any available motor nameplate information.

Refer to *Induction Motor Data* parameters which are determined by the Auto Tune feature for example the **Magnetising Current, Stator Resistance, Leakage Inductance, Mutual Inductance** and **Rotor time Constant** for model parameters.

Note Do not attempt to control motors whose rated current is less than 25% of the drive rated current. Poor motor control or Autotune problems may occur if you do.

PNO	Parameter Descriptions
<u>0455</u>	Rated Motor Current Rated motor current on the name plate
<u>0456</u>	Base Voltage The rated motor voltage on the name plate
<u>0457</u>	Base Frequency The base motor frequency on the name plate
<u>0458</u>	Motor Poles Motor poles on the nameplate
<u>0459</u>	Nameplate Speed Rated motor speed on the name plate
<u>0460</u>	Motor Power Motor power rating
<u>0461</u>	Power Factor Motor power factor on the name plate

Option Ethernet***Advanced Monitor::Communications::Option******Parameters::Option Comms::Option Ethernet***

Refer to the following Technical Manuals:

Product Code	Description	Part Number
7003-PN-00	PROFINET IO	HA501838U001
7003-IP-00	EtherNet IP	HA501842U001
7003-BP-00	BACnet IP	HA501939U001
7003-IM-00	Modbus TCP	HA501937U001

D-48 Parameter Reference

Pattern Generator

Parameters::Motor Control::Pattern Generator

The pattern generator function allows you to configure the Drive' PWM (Pulse Width Modulator) operation.

PNO Parameter Descriptions

0412 Stack Frequency

This parameter selects the PWM switching frequency of the output power stack.

The higher the switching frequency, the lower the level of motor audible noise. However, this is only achieved at the expense of increased drive losses and reduced stack current rating.

Max value is **Control Mode** dependant :

12 kHz for PMAC SVC

14kHz for IM SVC

16 kHz for V/Hz

0413 Random Pattern

This parameter selects between random pattern (quiet motor noise) or the more conventional fixed carrier PWM strategies. When TRUE, random pattern is enabled. For PMAC SVC control, random pattern is only suitable for Stack Frequency <=8kHz.

0414 Deflux Delay

Sets the minimum allowed delay between disabling and then re-enabling PWM production (i.e. stopping and starting the drive).

Functional Description

The Drive provides a unique quiet pattern PWM strategy in order to reduce audible motor noise. The user is able to select between the quiet pattern or the more conventional fixed carrier frequency method. With the quiet pattern strategy selected (RANDOM PATTERN enabled), audible motor noise is reduced to a dull hiss.

In addition, the user is able to select the PWM carrier frequency. This is the main switching frequency of the power output stage of the Drive. A high setting of carrier frequency (e.g. 6kHz) reduces audible motor noise but only at the expense of higher Drive losses and smooth motor rotation at low output frequencies. A low setting of carrier frequency (e.g. 3kHz), reduces Drive losses but increases audible motor noise.

PID**Advanced Setup::Application::PID****Advanced Monitor::Application::PID***

This function allows the AC30V to be used in applications requiring a trim to the reference, depending on feedback from an external measurement device. Typically this will be used for process control, i.e. pressure or flow.

PNO Parameter Descriptions**Setpoint**

This is connected to an Analog Input as part of the selected macro.

Feedback

This is connected to an Analog Input as part of the selected macro.

Enable

This is connected to a Digital Input as part of the selected macro. It globally resets the PID output and integral term when FALSE. **Enable** must be TRUE for the PID to operate.

Integral Defeat

This may be connected to a Digital Input as part of the selected macro. It resets the p integral term when FALSE.

1926 **PID Setpoint Negate**

Changes the sign of the Setpoint input

1927 **PID Feedback Negate**

Changes the sign of the Negate input

1928 **PID Proportional Gain**

This is the true proportional gain of the PID controller. When set to zero the PID Output is zero.

1929 **PID Integral TC**

The integral time constant of the PID controller.

1930 **PID Derivative TC**

The derivative time constant of the PID controller.

D-50 Parameter Reference

PNO Parameter Descriptions

1931 PID Output Filter TC

In order to help attenuate high frequency noise on the PID output, a first order output filter has been provided. This parameter determines the output filter time constant.

1932 PID Output Pos Limit

The maximum positive excursion (limit) of the PID output.

1933 PID Output Neg Limit

The maximum negative excursion (limit) of the PID output.

1934 PID Output Scaling

The overall scaling factor which is applied after the positive and negative limit clamps

1935 PID Output*

PID output monitor

1936 PID Error*

PID error monitor. This is Setpoint – Feedback.

Functional Description

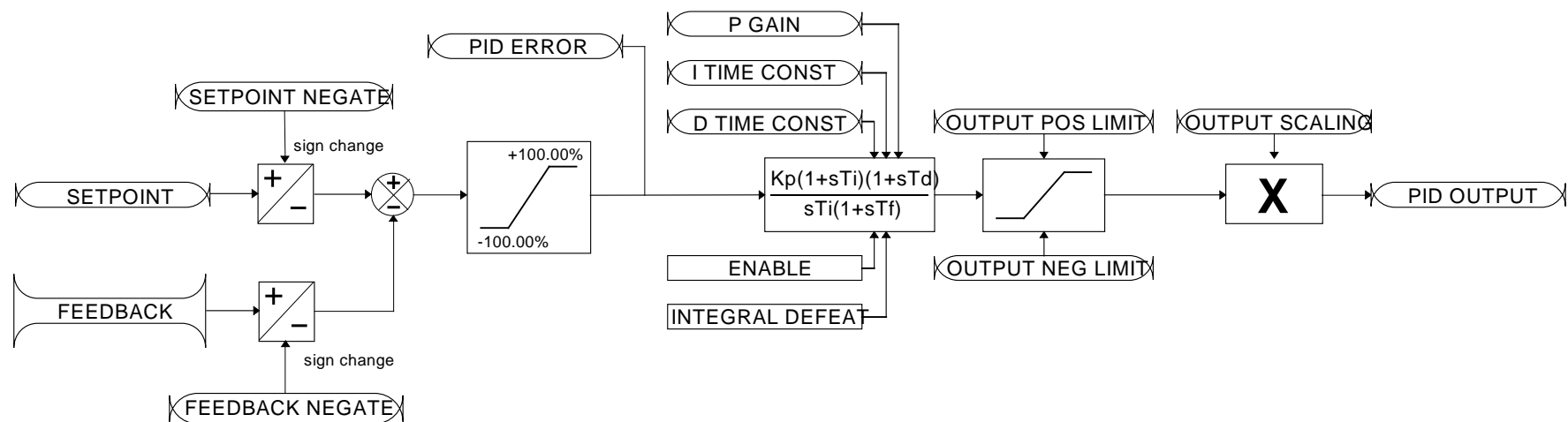

PMAC Flycatching**Parameters::Motor Control::PMAC Flycatching**

This block performs a directional speed search. It allows the Drive to seamlessly catch a spinning motor before controlling the motor to the desired setpoint. This is especially useful for large inertia fan loads, where drafts in building air ducts can cause a fan to `windmill`.

PNO Parameter Descriptions0689 **PMAC Flycatching Enable**

Enable the flycatching for PMAC motor

0690 **PMAC Fly Search Model**

PMAC Flycatching sequence can be triggered by different starting conditions:

ALWAYS:	All starts (after controlled or uncontrolled stop, or after a power-up)
TRIP or POWER-UP:	After uncontrolled stop, i.e. trip or coast, or after a power-up
TRIP:	After uncontrolled stop, i.e. trip or coast

0691 **PMAC Fly Search Time**

PMAC Fly Search Time to catch the right speed

0692 **PMAC Fly Load Level**

PMAC Fly Load Level during fly catching

0693 **PMAC Fly Active**

Diagnostic to show if the PMAC fly catching is active or inactive

0694 **PMAC Fly Setpoint**

PMAC Fly Setpoint

Functional Description

The flycatching function enables the drive to be restarted smoothly into a spinning motor.

D-52 Parameter Reference

PMAC Motor Data

Advanced Setup::Motor::MotorData PMAC

Parameters::Motor Control::PMAC Motor Data

Only available if PMAC Motor selected in **Control Mode**.

The PMAC Motor Data contains the parameters needed to run and control of a PMAC motor. A PMAC motor is a Permanent Magnet AC Motor with sinusoidal back EMF.

PNO Parameter Descriptions

0555 **PMAC Max Speed**

Set the motor's maximum speed (in rpm)

0556 **PMAC Max Current**

Set the motor's maximum current (Amps rms).

0557 **PMAC Rated Current**

Set the motor's rated current (Amps rms).

Refer to **Motor Current Percent** in the **Feedbacks** function. A value of 100% = PMAC rated Current.

0558 **PMAC Rated Torque**

Set the motor's rated torque.

Refer to **Actual Torque** in the **Feedbacks** function. A value of 100% = PMAC Rated Torque.

0559 **PMAC Motor Poles**

Set the number of motor poles, e.g. for a 10 poles motor enter "4".

0560 **PMAC Back EMF Const KE**

Set the motor's Back EMF line to line, rms value (Ke, Volts rms per 1000 rpm)

0561 **PMAC Winding Resistance**

Set the motor's resistance, line to line at 25 °C. This parameter is used within the current loop.

0562 **PMAC Winding Inductance**

Set the motor's inductance line to line at maximum current. This parameter is used within the current loop and is related to the overall proportional gain.

PNO Parameter Descriptions0563 **PMAC Torque Const KT**

Torque constant (Kt, Nm/A rms).

This parameter is used to compute the current demand given a torque demand :

$$\text{Current demand} = \text{Torque demand} / \text{KT}$$

564 **PMAC Motor Inertia**

Rotor inertia of motor from the datasheet.

565 **PMAC Thermal Time Constant**

Copper Thermal Time constant(s). If not known set to 300s.

This parameter is used for the motor thermal protection : I2T motor function.

It represents the time needed to reach 63% of the rated load of the motor if 100% of the rated current is applied to the motor (typical time constant of a first order low pass filter).

D-54 Parameter Reference

PMAC SVC

Parameters::Motor Control::PMAC SVC

Parameters related to the **SVC Control mode** of a PMAC Motor

PNO	Parameter Descriptions
-----	------------------------

<u>0467</u>	PMAC SVC Auto Values
-------------	-----------------------------

Selection of pre-calculated values

When selected, do some pre-calculation of the following PMAC SVC parameters:

PMAC SVC LPF Speed Hz

PMAC SVC P Gain

PMAC SVC I Gain Hz

<u>0468</u>	PMAC SVC LPF Speed Hz
-------------	------------------------------

Set the Low Pass Filter frequency of the estimated speed.

<u>0469</u>	PMAC SVC P Gain
-------------	------------------------

Set the Proportional gain of the PI corrector used for extracting speed and position.

<u>0470</u>	PMAC SVC I Gain Hz
-------------	---------------------------

Set the Integral frequency of the PI corrector used for extracting speed and position.

<u>0476</u>	PMAC SVC Open Loop Strt
-------------	--------------------------------

This parameter is used to enable/disable a specific startup procedure when the motor/drive is switched ON (starting rotation). This parameter is also used to work in up – down motion, where we need to go down to zero speed or crossing the zero speed point.

When set TRUE, the following procedure is applied each time the motor is switched on and before closing the speed loop, based on the external speed setpoint.

The drive must be used in speed loop mode.

When the drive is switched ON, the system is placed in open loop control.

Step 1:

For a time equal to the 'PMAC SVC Start Time' parameter, the current is ramped to the **PMAC SVC Start Cur** value. The sign is dependent upon the speed loop setpoint. A normal value is between 0.5 to 1s.

Step 2:

Once Step 1 is complete, the position is ramped in such a way as to follow the speed setpoint generated, based on the configuration

PNO Parameter Descriptions

(ramp, etc...), until the **PMAC SVC Start Speed** value is reached. The speed loop is then closed.

The ramp value must be kept low to ensure the motor follows the speed setpoint.

For a positive speed setpoint when the drive is switched ON :

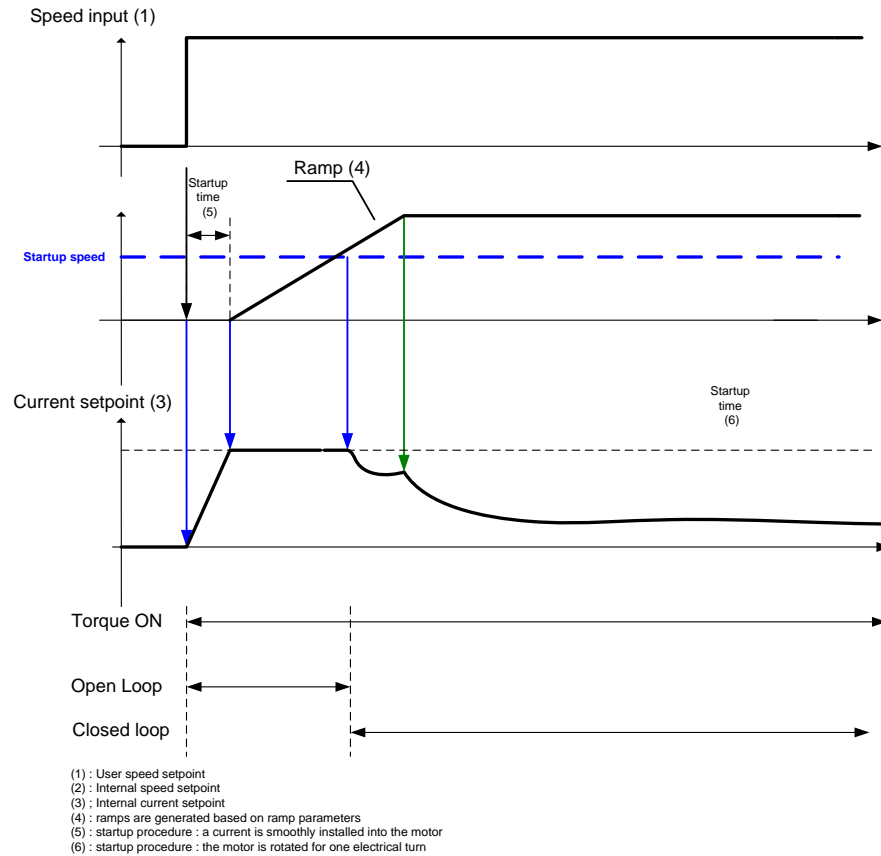

For a negative speed setpoint when the drive is switched ON :

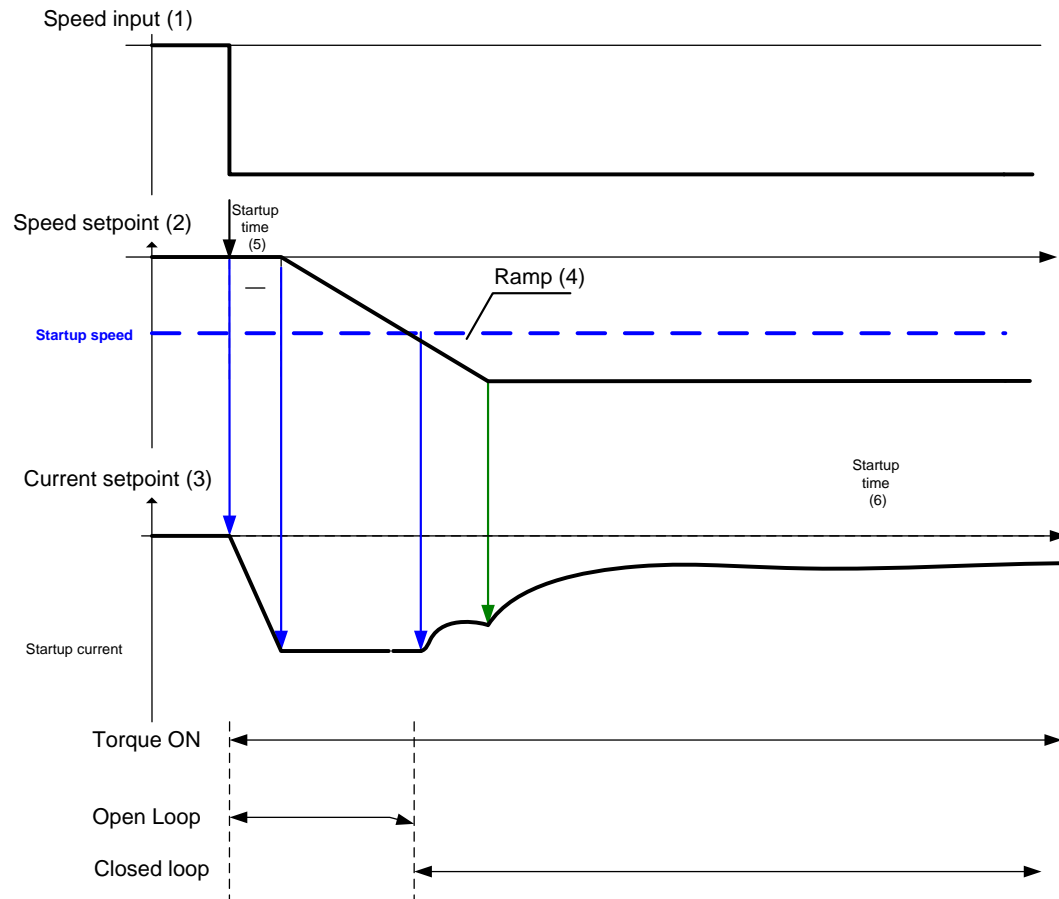

- (1) : User speed setpoint
- (2) : Internal speed setpoint
- (3) : Internal current setpoint
- (4) : ramps are generated based on ramp parameters
- (5) : startup procedure : a current is smoothly installed into the motor
- (6) : startup procedure : the motor is rotated for one electrical turn

PNO Parameter Descriptions0477 **PMAC SVC Start Time**

This parameter is used in conjunction with the **PMAC SVC Open Loop Strt** parameter. It selects the duration of Step 1 in the startup procedure used for starting motors:

- the time for the current ramping

The value is dependent upon the motor inertia + load inertia.

0478 **PMAC SVC Start Cur**

This parameter is used in conjunction with the **PMAC SVC Open Loop Strt** parameter. It selects the current level during the startup procedure used for starting motors.

The percentage value is a percentage of the nominal motor current (**PMAC Rated Current** of the **PMAC Motor Data** functions)

This value cannot be higher than 150% of the drive rating.

The default value of 10% is considered appropriate for most applications with light load, very low friction and low acceleration.

0479 **PMAC SVC Start Speed**

This parameter is used in conjunction with the **PMAC SVC Open Loop Strt** parameter. It selects the speed setpoint at which the speed control is switched from an open loop mode to a closed loop mode during the startup procedure used for starting motors.

The percentage value is a percentage of the maximum application speed (**100% Speed in RPM** of the **Scale Setpoint** functions). It should be set to an equivalent of 5% of the **PMAC Max Speed** of **PMAC Motor Data** function.

In open loop mode, the system is not controlled in speed mode. It must only be used to 'start' the motor under heavy conditions, or to temporarily reach the zero speed or crossing the zero speed setpoint. It is not intended to be used to control accurately a motion.

Up and Down Motion - Positive speed

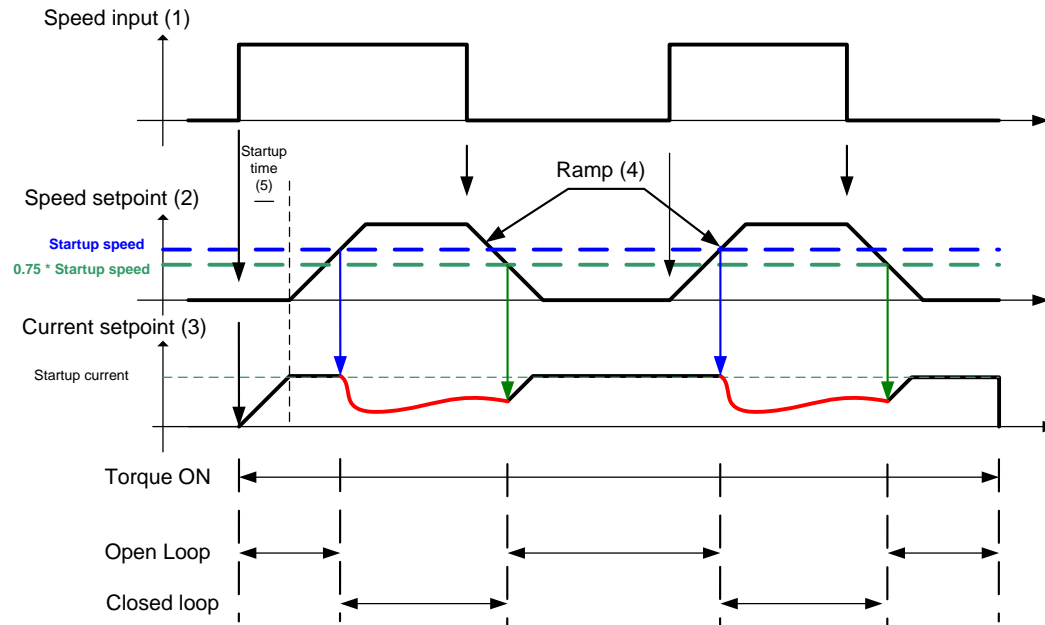

- (1) : User speed setpoint
- (2) : Internal speed setpoint
- (3) : Internal current setpoint
- (4) : ramps are generated based on ramp parameters
- (5) : startup procedure : a current is smoothly installed into the motor

PNO Parameter Descriptions

Negative Speed

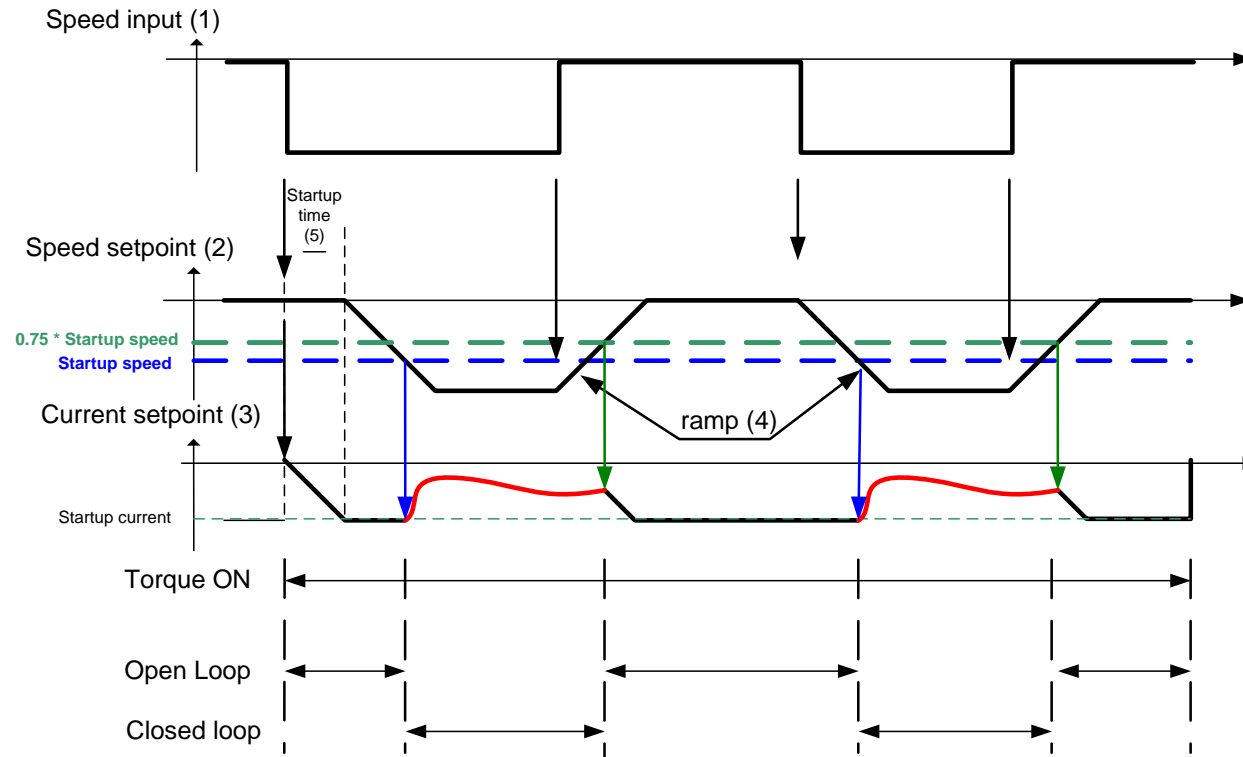

- (1) : User speed setpoint
- (2) : Internal speed setpoint
- (3) : Internal current setpoint
- (4) : ramps are generated based on ramp parameters
- (5) : startup procedure : a current is smoothly installed into the motor

Crossing zero speed

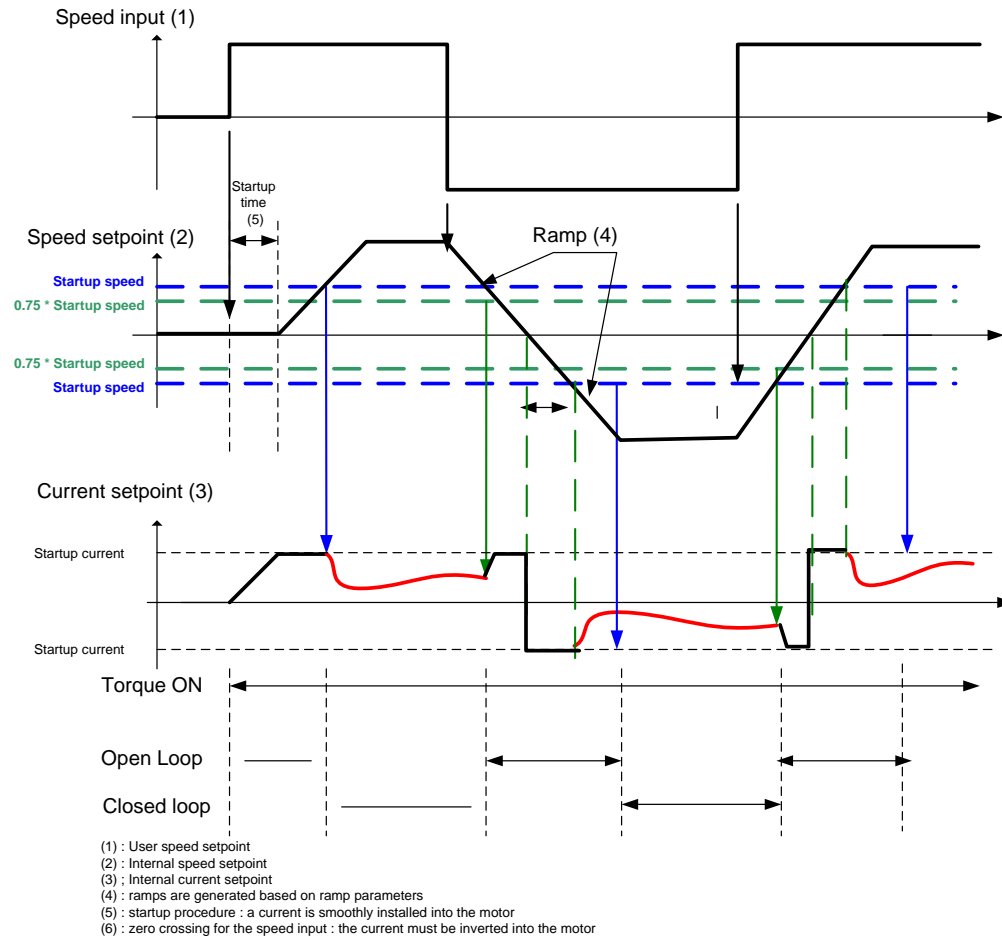

Preset Speeds**Advanced Setup::Application::Preset Speeds****Advanced Monitor::Application::Preset Speeds***

This function is available when the **Presets** macro is selected.

The **Presets** function selects 1 of 8 values to be used as a reference.

PNO	Parameter Descriptions
<u>1916</u>	Preset Speed 0 Preset Speed Output when Selected Preset equals 0
<u>1917</u>	Preset Speed 1 Preset Speed Output when Selected Preset equals 1
<u>1918</u>	Preset Speed 2 Preset Speed Output when Selected Preset equals 2
<u>1919</u>	Preset Speed 3 Preset Speed Output when Selected Preset equals 3
<u>1920</u>	Preset Speed 4 Preset Speed Output when Selected Preset equals 4
<u>1921</u>	Preset Speed 5 Preset Speed Output when Selected Preset equals 5
<u>1922</u>	Preset Speed 6 Preset Speed Output when Selected Preset equals 6
<u>1923</u>	Preset Speed 7 Preset Speed Output when Selected Preset equals 7
<u>1924</u>	Selected Preset* Monitor showing selected preset number
<u>1925</u>	Preset Speed Output* Monitor showing selected preset value

D-62 Parameter Reference

PNO Parameter Descriptions

Select 0

This is connected to a Digital Input as part of the selected macro. It provides bit 0 of the Selected Preset number.

Select 1

This is connected to a Digital Input as part of the selected macro. It provides bit 1 of the Selected Preset number.

Select 2

This is connected to a Digital Input as part of the selected macro. It provides bit 2 of the Selected Preset number.

Functional Description

Select 2	Select 1	Select 0	Selected Preset
FALSE	FALSE	FALSE	Preset Speed 0
FALSE	FALSE	TRUE	Preset Speed 1
FALSE	TRUE	FALSE	Preset Speed 2
FALSE	FALSE	FALSE	Preset Speed 3
TRUE	FALSE	TRUE	Preset Speed 4
TRUE	TRUE	FALSE	Preset Speed 5
TRUE	FALSE	FALSE	Preset Speed 6
TRUE	FALSE	FALSE	Preset Speed 7

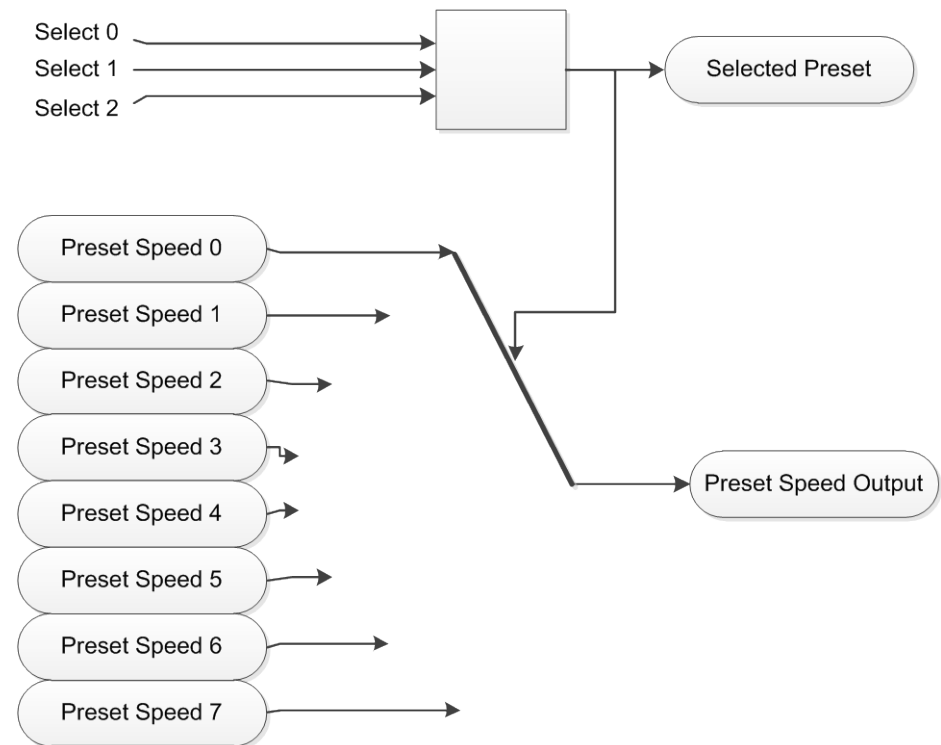

Profibus DP-V1

Parameters::Option Comms::Profibus DP-V1

Refer to Profibus DP-V1 Technical Manual HA501837U001

D-64 Parameter Reference

PROFINET IO

Advanced Monitor::Communications::Option

Parameters::Option Comms::Profinet IO

Refer to Profinet IO Technical Manual HA501838U001

Raise Lower**Advanced Setup::Application::Raise Lower****Advanced Monitor::Application::Raise Lower***

Appears when the **Raise/Lower** macro is selected.

The **Raise/Lower** function acts as an internal motorised potentiometer (MOP) used as a reference source.

PNO Parameter Descriptions1901 **RL Ramp Time**

Rate of change of the **Output**. Defined as the time to change from 0.00% to 100.00% . Note that the raise and lower rates are always the same.

1902 **RL Reset Value**

The value **Output** is set to when the **Reset Input** is TRUE.

1903 **RL Maximum Value**

The maximum value to which **Output** will ramp up to.

1904 **RL Minimum value**

The minimum value to which **Output** will ramp down to.

Reset Input

This is connected to a Digital Input as part of the selected Macro. When TRUE forces **Output** to track **Reset Value**.

Raise Input

This is connected to a Digital Input as part of the selected Macro. When TRUE causes **Output** to ramp up.

Lower Input

This is connected to a Digital Input as part of the selected Macro. When TRUE causes **Output** to ramp down.

1905 **Raise Lower Output***

The ramp output monitor. **Output** is preserved during the power-down of the Drive.

D-66 Parameter Reference

Functional Description

The table below describes how **Output** is controlled by **Raise Input**, **Lower Input** and **Reset Input**.

Reset	Raise Input	Raise Output	Action
TRUE	Any	Any	Output tracks Reset Value
FALSE	TRUE	FALSE	Output ramps up to Maximum Value at Ramp Time
FALSE	FALSE	TRUE	Output ramps down to Minimum Value at Ramp Time
FALSE	FALSE	FALSE	Output not changed. *
FALSE	TRUE	TRUE	Output not changed. *

* If **Output** is greater than **Maximum Value** the **Output** will ramp down to **Maximum Value** at **Ramp Time**. If **Output** is less than **Minimum Value** the **Output** will ramp up to **Minimum Value** at **Ramp Time**.

IMPORTANT: *If **Maximum Value** is less than or equal to **Minimum Value**, then **Output** is set to **Maximum Value**.*

Ramp

Parameters::Motor Control::Ramp

This function forms part of the reference generation. It provides the facility to control the rate at which the Drive will respond to a changing setpoint demand.

PNO Parameter Descriptions

0484 Seq Stop Method VHz

Selects stopping mode that the controller will use once the run command has been removed. The choices are:

Enumerated Value : Stopping Mode

0 : DISABLED VOLTAGE, (COAST)

1 : RAMP

2 : STOP RAMP

3 : DC INJECTION (only Volts/Hz control mode)

When VOLTAGE DISABLED (COAST) is selected the motor will free-wheel. When RAMP is selected the Drive will decelerate using the reference ramp deceleration time, provided it is non-zero. When STOP RAMP is selected the motor will decelerate in **Stop Ramp Time**. When DC INJECTION is selected the motor is stopped by applying dc current.

1257 Seq Stop Method SVC

Selects stopping mode that the controller will use once the run command has been removed. The choices are:

Enumerated Value : Stopping Mode

0 : DISABLED VOLTAGE, (COAST)

1 : RAMP

2 : STOP RAMP

When VOLTAGE DISABLED (COAST) is selected the motor will free-wheel. When RUN RAMP is selected the Drive will decelerate using the reference ramp deceleration time, provided it is non-zero. When STOP RAMP is selected the motor will decelerate in **Stop Ramp Time**.

0485 Ramp Type

Select the ramp type:

Enumerated Value : Ramp Type

0 : LINEAR

1 : S

D-68 Parameter Reference

PNO Parameter Descriptions

0486 **Acceleration Time**

The time that the Drive will take to ramp the setpoint from 0.00% to 100.00% when **Ramp Type** is LINEAR.

0487 **Deceleration Time**

The time that the Drive will take to ramp the setpoint from 100.00% to 0.00% when **Ramp Type** is LINEAR.

0488 **Symmetric Mode**

Select whether to use **Acceleration Time** and **Deceleration Time** pair of ramp rates, or to use **Symmetric Time** to define the ramp rate for the Drive.

PNO Parameter Descriptions	
<u>0489</u>	<p>Symmetric Time</p> <p>The time that the Drive will take to ramp from 0.00% to 100.00% and from 100.00% to 0.00% when Symmetric Mode is TRUE.</p>
<u>0490</u>	<p>Sramp Continuous</p> <p>When TRUE, and S ramp is selected in Ramp Type, forces a smooth transition if the speed setpoint is changed when ramping. The curve is controlled by the Sramp Acceleration and Sramp Jerk1 to Sramp Jerk 4 parameters. When FALSE, there is an immediate transition from the old curve to the new curve.</p>
<u>0491</u>	<p>Sramp Acceleration</p> <p>Sets the acceleration rate in units of percent per second², i.e. if the full speed of the machine is 1.25m/s then the acceleration will be: $1.25 \times 75.00\% = 0.9375\text{m/s}^2$</p>
<u>0492</u>	<p>Sramp Deceleration</p> <p>This functions in the same way as Sramp Acceleration above.</p>
<u>0493</u>	<p>Sramp Jerk 1</p> <p>Rate of change of acceleration for the first segment of the curve in units of percent per second³, i.e. if the full speed of the machine is 1.25m/s then the jerk will be: $1.25 \times 50.00\% = 0.625\text{m/s}^3$</p>
<u>0494</u>	<p>Sramp Jerk 2</p> <p>Rate of change of acceleration in units of percent per second³ for segment 2</p>
<u>0495</u>	<p>Sramp Jerk 3</p> <p>Rate of change of acceleration in units of percent per second³ for segment 3</p>
<u>0496</u>	<p>Sramp Jerk 4</p> <p>Rate of change of acceleration in units of percent per second³ for segment 4</p>
<u>0497</u>	<p>Ramp Hold</p> <p>When TRUE the output of the ramp is held at its last value</p>
<u>0498</u>	<p>Ramping Active</p> <p>Set TRUE when ramping.</p>
<u>0499</u>	<p>Ramp Spd Setpoint Input</p> <p>Input speed setpoint to the ramp</p>

D-70 Parameter Reference

PNO Parameter Descriptions	
<u>0500</u>	Ramp Speed Output Output speed
<u>0501</u>	Jog Setpoint The setpoint is the target reference that the Drive will ramp to
<u>0502</u>	Jog Acceleration Time The time that the Drive will take to ramp the jog setpoint from 0.00% to 100.00%.
<u>0503</u>	Jog Deceleration Time The time that the Drive will take to ramp the jog setpoint from 100.00% to 0.00%.
<u>0504</u>	Stop Ramp Time Rate at which the demand is ramped to zero after the ramp has been quenched
<u>0505</u>	Zero Speed Threshold Hold for zero speed detection used by stop sequences
<u>0506</u>	Zero Speed Stop Delay Sets the time at which the Drive holds zero speed before quenching after a normal stop or a jog stop. This may be particularly useful if a mechanical brake requires time to operate at zero speed, or for jogging a machine to position
<u>0507</u>	Quickstop Time Limit Maximum time that the Drive will try to Quickstop, before quenching
<u>0508</u>	QuickstopTime Rate at which the Speed Demand is ramped to zero when Quickstop is active
<u>0509</u>	Final Stop Rate Rate at which any internally generated setpoint trims are removed. For example, the trim due to the slip compensation in Volts/Hz control mode.

Functional Description

The s-ramp output takes the form shown below.

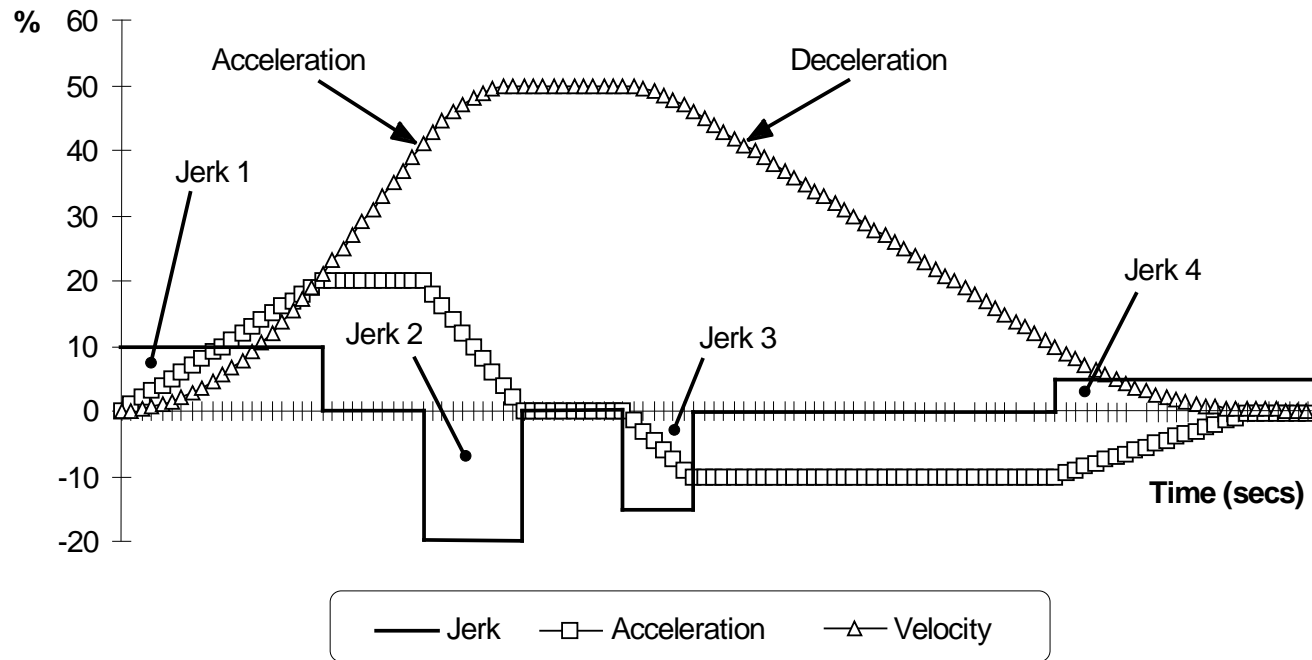

D-72 Parameter Reference

Read Process

Advanced Setup::Communications::Option

Parameters::Option Comms::Read Process

Refer to any of the following Technical Manuals:

Product Code	Description	Part Number
7003-PB-00	Profibus DP-V1	HA501837U001
7003-PN-00	PROFINET IO	HA501838U001
7003-DN-00	DeviceNet	HA501840U001
7003-CN-00	ControlNet	HA501936U001
7003-CB-00	CANopen	HA501841U001
7003-IP-00	EtherNet IP	HA501842U001
7003-EC-00	EtherCAT	HA501938U001
7003-BP-00	BACnet IP	HA501939U001
7003-BN-00	BACnet MSTP	HA501940U001
7003-RS-00	Modbus RTU	HA501839U001
7003-IM-00	Modbus TCP	HA501937U001
7003-CC-00	CC-LINK	HA501941U001

Real Time Clock

Parameters::Device Manager::Real Time Clock

PNO	Parameter Descriptions
-----	------------------------

<u>1186</u>	Time and Date
-------------	----------------------

Time and Date in the format yyyy/mm/dd hh:mm:ss

Functional Description

IO Option Fitted with Real Time Clock

When an IO Option is fitted, (part number 7004-01-00 or 7004-02-00), this parameter reports the time from the associated Real Time Clock hardware. On receiving an IO Option from the factory the time is not set and the value will be fixed at 1970/01/01 00:00:00. To set the correct time write to parameter 1186. Once set the RTC hardware on the IO option will maintain the time even when power to the drive is removed.

No IO Option

When no IO Option is fitted this parameter may be used as the destination of a broadcast time from a communications master.

D-74 Parameter Reference

Scale Setpoint

Parameters::Motor Control::Scale Setpoint

This function defines 100% speed in RPM.

PNO	Parameter Descriptions
-----	------------------------

0464	100% Speed in RPM
------	--------------------------

	Maximum rpm set by the user
--	-----------------------------

Functional Description

The Drive is commanded to run the motor at a certain speed, which is derived from various sources, such as comms, analog inputs, commands from the keypad, etc. All these speed commands are expressed as a percentage. The percentage is referenced to this parameter. So, for example, if this parameter is set to 3000 rpm, and the user commands 100% speed, then the motor should turn at 3000rpm.

This parameter also represents the maximum speed available, since (apart from a small allowance for process trims) the speed commands are not allowed to exceed 100%.

Sequencing**Parameters::Motor Control::Sequencing**

These parameters allow the user of the AC30V to monitor the status and affect the behaviour of the DS402 drive state machine as described in detail in Appendix B “Sequencing Logic”.

PNO	Parameter Descriptions
<u>0591</u>	Local Local (GKP) Control and/or Reference.
<u>0592</u>	Local Reference Local Reference from GKP.
<u>0610</u>	App Cmd Word Control Word from Application (Terminals).
<u>0627</u>	Comms Cmd Word Control Word from Fieldbus.
<u>0644</u>	Command Word Monitor (read-only) Control Word updated from the active source.
<u>0661</u>	Status Word This is the DS402 Status Word
<u>0678</u>	Sequencing State Drive DS402 Sequencing State.
<u>0679</u>	Switch On Timeout Time allowed for line contactor to close when entering the Switched On state from Switched Off state. If this time is non-zero, a Line Contactor trip will occur if the DC Link Voltage remains low until the timeout expires. If the timeout is set to zero, an Under Voltage trip will occur immediately.
<u>0680</u>	App Reference Reference from terminals (via. the application)
<u>0681</u>	Comms Reference Reference from Fieldbus

D-76 Parameter Reference

PNO Parameter Descriptions

0682 Reference

Monitor (read-only) Reference updated from the active source. This will either be the value of the **Local Reference**, **App Reference** (terminals) or **Comms Reference** depending on which source is currently selected.

Setup Wizard

Advanced Setup::Wizard

Parameters::Device Manager::Setup Wizard

These parameters configure the operation of the **Setup Wizard**.

PNO Parameter Descriptions

1005 **Language**

Identifies the currently selected language. The languages supported are:

- 0 English
- 1 French
- 2 German
- 3 Spanish
- 4 Italian

1006 **Run Setup?**

Changing this parameter to TRUE will cause the GKP to re-start the Setup Wizard. This parameter is automatically reset to FALSE on exiting the Setup Wizard.

Functional Description

The operation of the Setup Wizard is described in Chapter 9.

D-78 Parameter Reference

Skip Frequencies

Advanced Setup::Application::Skip Frequencies

Function availability depends on macro selected.

This function is used to prevent the Drive operating at frequencies that cause mechanical resonance in the load.

PNO	Parameter Descriptions
<u>1908</u>	Skip Band 1 The width of skip band 1 in Hz.
<u>1909</u>	Skip Frequency 1 The centre frequency of skip band 1 in Hz.
<u>1910</u>	Skip Band 2 The width of skip band 2 in Hz.
<u>1911</u>	Skip Frequency 2 The centre frequency of skip band 2 in Hz.
<u>1912</u>	Skip Band 3 The width of skip band 3 in Hz.
<u>1913</u>	Skip Frequency 3 The centre frequency of skip band 3 in Hz.
<u>1914</u>	Skip Band 4 The width of skip band 4 in Hz.
<u>1915</u>	Skip Frequency 4 The centre frequency of skip band 4 in Hz.

Functional Description

Four programmable skip frequencies are available to avoid resonances within the mechanical system. Enter the value of frequency that causes the resonance using a **Frequency** parameter and then program the width of the skip band using its **Band** parameter. The Drive will then avoid sustained operation within the forbidden band as shown in the diagram. The skip frequencies are symmetrical and thus work in forward and reverse.

Setting a **Frequency** to 0 disables the corresponding band. Setting a **Band** to 0 causes the value of **Band 1** to be used for this band.

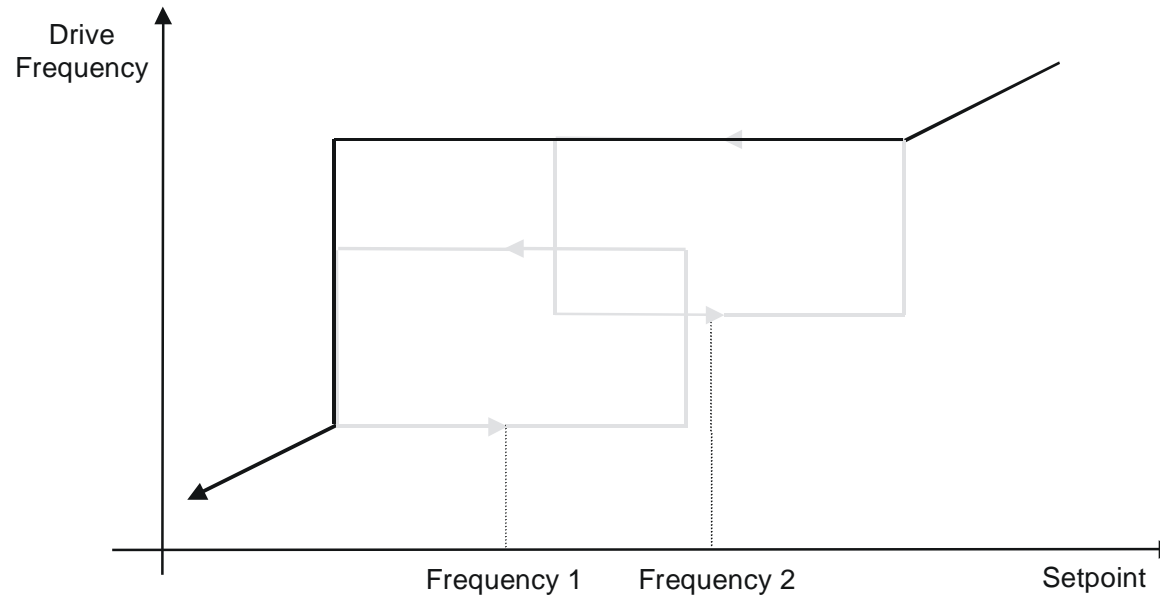

The behaviour of this function is illustrated below.

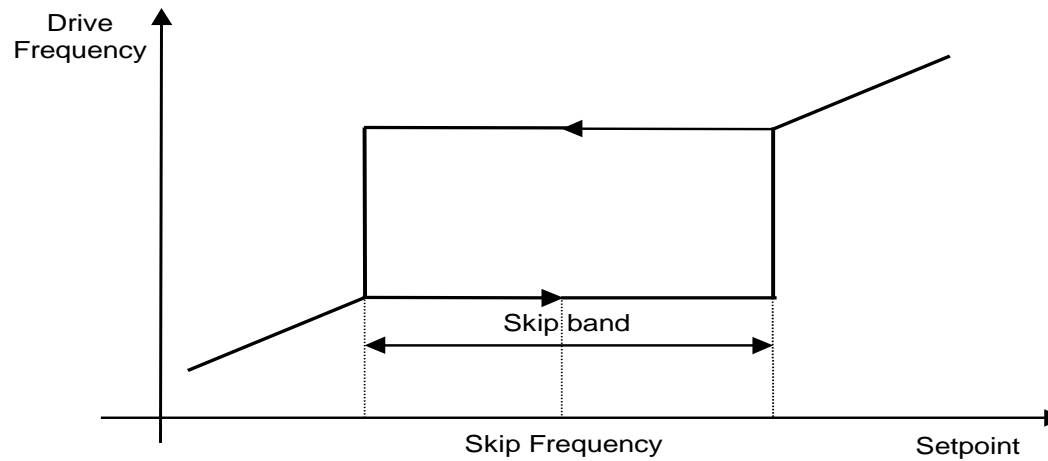

D-80 Parameter Reference

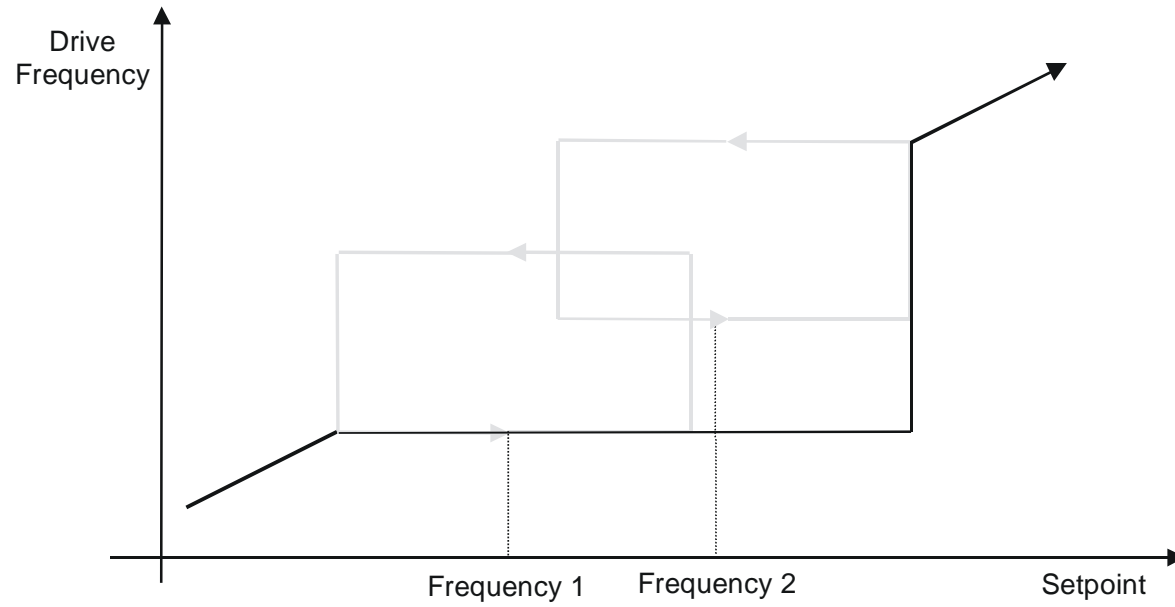

Slew Rate

Parameters::Motor Control::Slew Rate

This function prevents over-current and over-voltage faults occurring due to a rapidly changing setpoint.

PNO	Parameter Descriptions
<u>0360</u>	Slew Rate Enable Enable/Disable slew rate limit
<u>0361</u>	Slew Rate Accel Limit Maximum rate at which the setpoint can be changed away from zero
<u>0362</u>	Slew Rate Decel Limit Maximum rate at which the setpoint can be changed towards zero

Functional Description

The **Slew Rate** limit obtains the setpoint from the output of the application, correctly scaled by the **Reference** feature. The rate of change limits are applied and the setpoint is then passed on for further processing.

When the braking feature determines that the internal dc link voltage is too high it issues a Hold signal. This causes the **Slew Rate** limit function to hold the setpoint at its current value. This typically lasts for only 1ms, time for the excess energy to be dumped into the dynamic braking resistor.

D-82 Parameter Reference

Slip Compensation

Parameters::Motor Control::Slip Compensation

Designed for VOLTS/Hz motor Control Mode.

The slip compensation function allows the Drive to maintain motor speed in the presence of increased load.

PNO	Parameter Descriptions
<u>0354</u>	Slip Compensatn Enable Enable/Disable slip compensation
<u>0356</u>	SLP Motoring Limit Maximum compensated speed in motor control
<u>0357</u>	SLP Regen Limit Maximum compensated speed in regen mode

Functional Description

Based on the rated speed, the no load speed and the rated load of the motor, the **Slip Compensation** feature adjusts the demand frequency to compensate for any speed reduction resulting from the load.

Soft Menus***Parameters::Device Manager::Soft Menus*****PNO Parameter Descriptions****1188 Favourites**

An array of PNOs that identifies the parameters to be shown in the Favourites menu



1311 Setup

An array of PNOs that identifies the parameters to be shown in the Setup menu

1270 Monitor

An array of PNOs that identifies the parameters to be shown in the Monitor menu

Functional Description

The Soft Menus group of parameters are used to populate the associated menus depending on the associated application, (Setup and Monitor) or the requirements of the location, (Favourites). The contents of the Setup and Monitor menu may only be set by the application itself. The contents of the Favourites menu may be set by writing to the parameters in the Favourites array. Alternatively parameters may be added to or removed from the Favourites menu by use of the GKP. Navigate to the parameter of interest and hold the OK key until the attributes screen is shown. If the parameter is not already in the Favourites menu a pressing the Soft Right key adds the parameter to Favourites. This operation is indicated by the icon  + . Similarly, to remove a parameter from Favourites, navigate to the parameter in the Favourites menu then press OK until the parameter attributes are shown. Remove the parameter from Favourites by pressing the Soft Right key. This operation is indicated by the icon  - .

D-84 Parameter Reference

Spd Direct Input

Parameters::Motor Control::Spd Direct Input

Only apply to SVC control mode, IM or PMAC.

PNO Parameter Descriptions

0528 **Direct Input Selection**

The direct input to the speed loop is an analog input which is sampled synchronously with the speed loop. This ensures that the speed loop always has the most up-to-date value of the input, allowing it to respond faster. Either of the two analog inputs can be selected as the direct input. If NONE is selected, the input is set to zero. When not in use, it should be disabled by selecting NONE.

Enumerated Value : Direct IP Select

0 : NONE

1 : ANIN1

2 : ANIN2

0529 **Direct Input Ratio**

The Direct Input is multiplied by this parameter.

0530 **Direct Input Pos Limit**

This limits the upper value of the Direct Input.

0531 **Direct Input Neg Limit**

This limits the lower value of the Direct Input.

Functional Description

The Drive is commanded to run the motor at a certain speed, which is derived from various sources, such as comms, analog inputs, commands from the keypad, etc. Most of these are derived from sources which respond relatively slowly, eg every 1ms. For processes which require a faster response, the direct input is provided. This is an analog input which is sampled synchronously with the speed loop, as described above. It is added on to the other sources of speed command to give a total speed command.

Spd Loop Diagnostics

Parameters::Motor Control::Spd Loop Diagnostics

Refer to the diagram in **Spd Loop Settings** function.

Only apply to SVC control mode, IM or PMAC.

PNO	Parameter Descriptions
<u>0533</u>	Total Spd Demand RPM This diagnostic shows the final values of the speed demand in rpm obtained after summing all sources. This is the value which is presented to the speed loop
<u>0534</u>	Total Spd Demand % This diagnostic shows the final values of the speed demand as a % of 100% Speed in RPM of the Scale Setpoint obtained after summing all sources. This is the value which is presented to the speed loop.
<u>0535</u>	Speed Loop Error This diagnostic shows the difference between the total speed demand and the speed feedback
<u>0536</u>	Speed PI Output This diagnostic shows the torque demand due to the speed loop PI output, not including any feedforward terms.

D-86 Parameter Reference

Spd Loop Settings

Parameters::Motor Control::Spd Loop Settings

This function block controls the speed of the motor by comparing the actual speed to the demanded speed, and applying more or less torque in response to the error.

Only apply to SVC control mode, IM or PMAC.

PNO	Parameter Descriptions
<u>1246</u>	Speed Loop Auto Set Only for PMAC Motor TRUE : Allows to automatically calculate speed loop control parameters : Speed Loop P Gain and Speed Loop I Time . To do a correct estimation, Speed Loop mot Inert should be correctly filled in. FALSE : no automatic calculation
<u>1247</u>	Speed Loop mot Inert Only for PMAC Motor Enter the correct inertia ratio between the load and the motor (For a no load condition, a value of 0.1 should be used). This is used to automatically estimate the correct Speed Loop P Gain and Speed Loop I Time .
<u>1248</u>	Speed Loop Bandwidth Only for PMAC Motor When Speed Loop Auto Set is TRUE, allows to select the speed loop bandwidth level : Low :provides a low speed loop bandwidth Medium : provides a medium speed loop bandwidth High : provides a high speed loop bandwidth
<u>0515</u>	Speed Loop P Gain Sets the proportional gain of the loop. Speed error x proportional gain = torque percent.
<u>0516</u>	Speed Loop I Time This is the integral time constant of the speed loop. A speed error which causes the proportional term to produce a torque demand T, will cause the integral term to also ramp up to a torque demand T after a time equal to Speed Loop I Time .

PNO Parameter Descriptions0517 **Speed Loop Int Defeat**

When TRUE, the integral term does not operate.

0518 **Speed Loop Int Preset**

The integral term will be preset to this value when the drive starts.

0519 **Spd Loop Dmd Filt TC**

The speed demand is filtered to reduce ripple. The filter is first order with time constant equal to the value of this parameter.

0520 **Spd Loop Fbk Filt TC**

The speed feedback is filtered to reduce ripple. The filter is first order with time constant equal to the value of this parameter.

0521 **Spd Loop Aux Torq Dmd**

When the drive is operating in speed control mode, the value of this parameter is added on to the torque demand produced by the speed loop PI. When the drive is operating in torque control mode (i.e. **Set Torq Ctrl Only** is TRUE) the speed loop PI does not operate, and the torque demand becomes the sum of this parameter plus the DIRECT INPUT (if selected).

0523 **Spd Loop Adapt Thres**

If the speed demand is less than the **Spd Loop Adapt Thres**, the speed loop proportional gain is the **Spd Loop Adapt Pgain**.

0524 **Spd Loop Adapt Pgain**

Proportional gain used if speed demand < **Spd Loop Adapt Thres**.

0525 **Spd Demand Pos Lim**

This sets the upper limit of the speed demand.

0526 **Spd Demand Neg Lim**

This sets the lower limit of the speed demand.

0527 **Sel Torq Ctrl Only**

Selects between Speed Control mode and Torque Control mode. When TRUE, (Torque Control mode) the torque demand output from the speed loop feature is the sum of the Direct Input plus the **Spd Loop Torq Dem** parameter.

Functional Description

The speed error (speed demand minus speed feedback) is calculated and processed via a proportional + integral (PI) controller. The output of the PI controller is a torque demand, which is passed directly to the torque control feature.

When the drive is in SENSORLESS VEC mode, the speed feedback is calculated from the voltages and currents flowing in the motor, and the motor model.

D-88 Parameter Reference

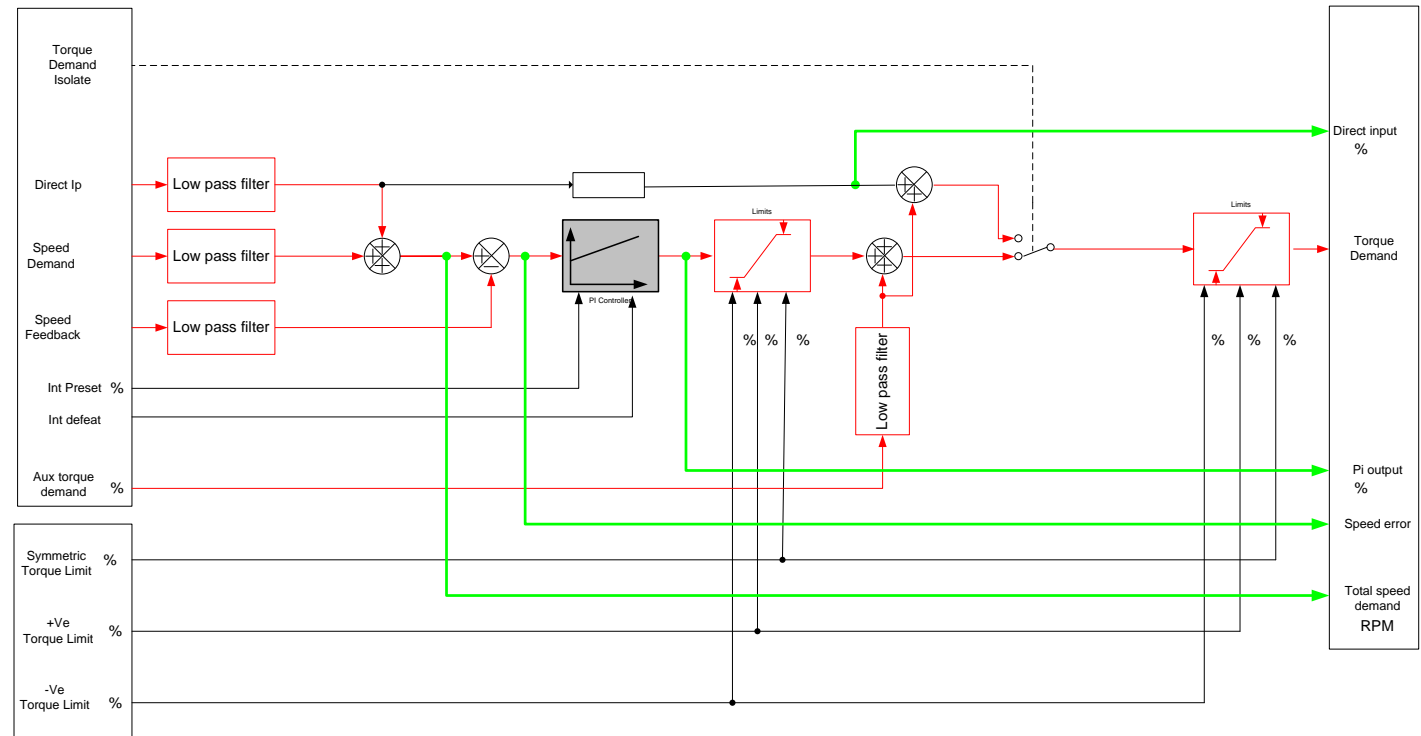

Speed Ref

Parameters::Motor control::Speed Ref

This function holds all the parameters concerning the generation of the setpoint reference (reference ramp, speed trim, setpoint reverse, etc.).

PNO	Parameter Descriptions
<u>1264</u>	Ref Min Speed Clamp Minimum value for Ramp Spd Output
<u>1265</u>	Ref Max Speed Clamp Maximum value for Ramp Spd Output
<u>1266</u>	Ref Speed Trim The trim is added to the ramp output to form the Ramp Spd Output (unconditionally in remote mode). In local mode, it is added is the Ref Trim Local parameter is set to TRUE
<u>1267</u>	Ref trim Local When TRUE, the trim is added to the ramp output in local mode. When FALSE, the trim is not added to the ramp output in local mode.

Functional Description

D-90 Parameter Reference

Stabilisation

Parameters::Motor Control::Stabilisation

Designed for VOLTS/Hz motor Control Mode.

PNO	Parameter Descriptions
-----	------------------------

<u>0364</u>	Stabilisation Enable
-------------	-----------------------------

	Enable/Disable stabilisation
--	------------------------------

Functional Description

Enabling this function reduces the problem of unstable running in induction motors. This can be experienced at approximately half full speed, and under low load conditions.

Stack Inv Time

Parameters::Motor Control::Stack Inv Time

The purpose of the inverse time is to automatically reduce the drive current limit in response to prolonged overload conditions.

For a short time given by **Stack Short Overl'd Sec**, the drive is able to provide the **Stack Short Overl'd %**.

For a long time given by **Stack Long Overl'd Sec**, the drive is able to provide the **Stack Long Overl'd %**.

These 2 protections work in parallel, the output limit current is the maximum value if **Stack Inv Time Active** = False. If **Stack Inv Time Active** = True, the current limit is determined by **Stack Long Overl'd %**.

the current limit is not yet ramped down. If already ramped down, the current limit is due to the long overload.

When the maximum overload value is reached, the inverse time current limit is ramped down. The rate at which the inverse time current limit is ramped to the **Stack Aiming Point %** is defined by **Inverse Time Down Rate**. When the overload condition disappears, the inverse time current limit is ramped up. The rate at which the inverse time current limit is ramped to the maximum value is defined by **Inverse Time Up Rate**.

% Are all referring to drive/stack ratings.

PNO	Parameter Descriptions
0343	100% Stack Current Stack rating in rms amps corresponding to 100% stack current
0344	Stack Long Overl'd % Overload value in % of the stack amps for long overload condition
0345	Stack Long Overl'd Sec Maximum duration under long overload condition (typically 60s)
0346	Stack Short Overl'd % Overload value in % of the stack amps for short overload condition
0347	Stack Short Overl'd Sec Maximum duration under short overload condition (typically 3s)
0348	Stack Aiming Point % Current in % where the power stack can undertake the load current permanently
0349	Stack Inv Time Output % Actual output current limit as a % of the stack current

D-92 Parameter Reference

PNO Parameter Descriptions

0350 Inverse Time Up Rate

Ramp value to ramp up current when overload condition disappears

0351 Inverse Time Down Rate

Ramp value to reach the aiming point under prolonged overload condition

0352 Stack Inv Time Warning

The protection starts to integrate overload conditions

0353 Stack Inv Time Active

The drive protection is limiting the output current

Functional Description

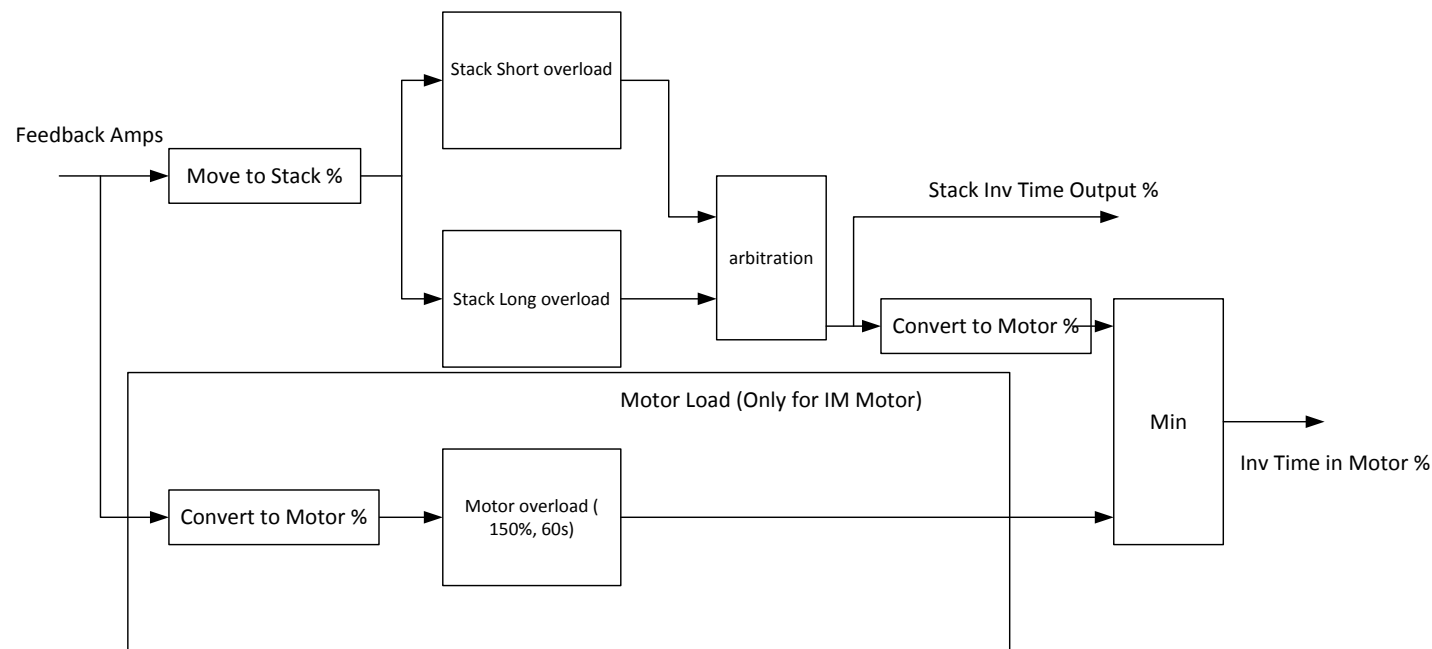

Stack Short Overload : is using 180% of the Heavy Duty rating, for 3s.

Stack Long Overload : is using the overload mode selected in the Duty Selection parameter.

Inv Time in Motor % is used to limit the current. It is one of the inputs of the **Current Limit** Function features

Stall Trip**Parameters::Trips::Stall Trip**

The function protects the motor from damage that may be caused by continuous operation beyond specification.

PNO Parameter Descriptions0906 **Stall Limit Type**

Enumerated Value : Stall Limit Type

TORQUE

CURRENT

TORQUE OR CURRENT

This parameter determines whether the stall trip operates on motor torque, on motor current, on motor torque or motor current.

0907 **Stall Time**

The time after which a stall condition will cause a trip.

0909 **Stall Torque Active**

TRUE if tripped under torque trip operation

0910 **Stall Current Active**

TRUE is tripped under current trip operation

0911 **Stall Speed Feedback**

A copy of the speed Feedback in Hz

Functional Description

If Stall Limit Type is set to TORQUE and the estimated load exceeds the active TORQUE LIMIT for a time greater than **Stall Time**, then the stall trip will become active.

If the Stall Limit Type is set to CURRENT and the measured current exceeds the active Current Limit for a time greater than **Stall Time**, then the stall trip will become active.

D-94 Parameter Reference

Torque Limit

Parameters::Motor Control::Torque Limit

This function allows you to set the maximum level of motor rated torque which is allowed before torque limit action occurs. If the estimated motor torque is greater than the **Actual Pos Torque Limit** value, the motor speed is controlled to maintain the torque at this level. A similar situation occurs if the estimated motor torque is less than the **Actual Neg Torque Limit** value.

The torque limit function has separate positive and negative torque limits. In addition, a symmetric main torque limit is also provided. The lowest positive and negative torque limits (including any current limit or inverse time current limit action) is indicated in the **Actual Pos Torque Limit** and **Actual Neg Torque Limit** diagnostic. These values determine the absolute motor torque limits.

PNO	Parameter Descriptions
<u>0415</u>	Positive Torque Limit This parameter sets the maximum allowed level of positive motor torque.
<u>0416</u>	Negative Torque Limit This parameter sets the maximum allowed level of negative motor torque
<u>0417</u>	Main Torque Limit This parameter sets the symmetric limit on the maximum allowed motor torque.
<u>0418</u>	Quickstop Torque Limit This parameter sets the torque limit used during a Quickstop.
<u>0419</u>	Symmetric Torque Limit When TRUE, the Negative Torque Limit is forced to reflect the Positive Torque Limit parameter.
<u>0420</u>	Actual Pos Torque Limit This diagnostic indicates the final actual positive torque limit including any current limit or inverse time current limit action.
<u>0421</u>	Actual Neg Torque Limit This diagnostic indicates the final actual negative torque limit including any current limit or inverse time current limit action.

Functional Description

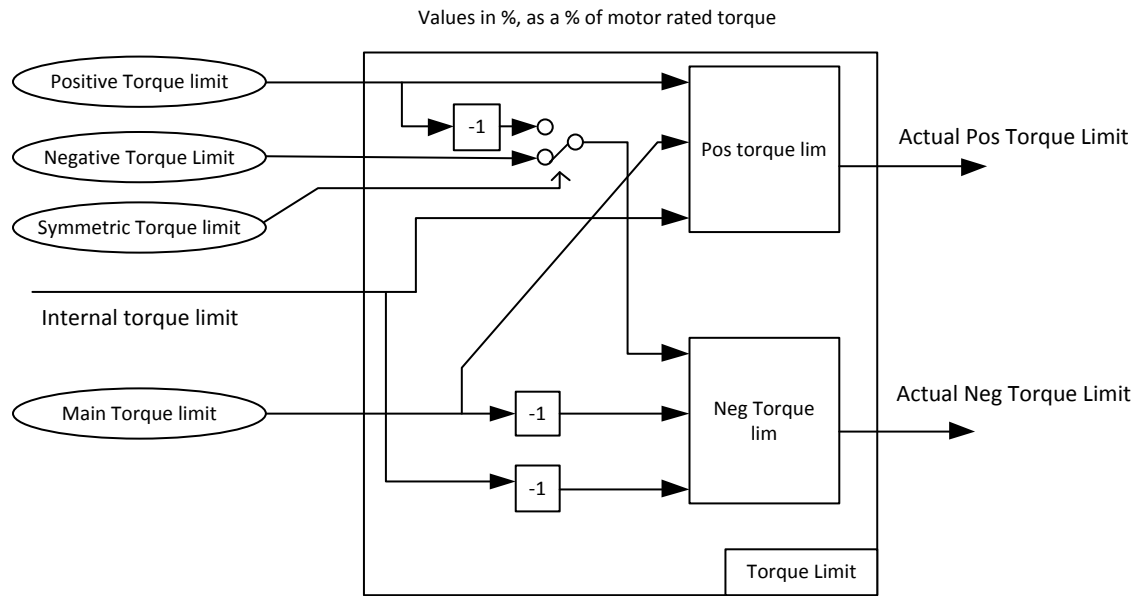

D-96 Parameter Reference

Trips History

Monitor

Parameters::Trips::Trips History

PNO Parameter Descriptions

0895 Recent Trips[10]

The Recent Trips array is a record of the last 10 faults that caused the drive to disable the stack. Each entry has the same format as the First Trip parameter, (see [Trips Status](#)). The most recent fault is the first entry in the array, (Recent Trips[0]).

Functional Description

This function provides a view of the ten most recent trips that caused the Drive to stop. Every time a new trip occurs this is entered as TRIP 1 (NEWEST) and the other recorded trips are moved down. If more than ten trips have occurred since the drive was configured then only the ten most recent trips will be available for inspection.

These parameters are preserved through a power failure.

Trips Status**Parameters::Trips::Trips Status****PNO Parameter Descriptions**0696 **First Trip**

An enumerated value that shows the trip that caused the AC30 to disable the stack. When multiple trips are active at the same time, (for example Over Current followed by Over Temperature), this parameter shows the first trip that the AC30 detected. Refer to Chapter 10 “Trips and Fault Finding”, for details of each trip source.

0697 **Enable 1 - 32**

A 32-bit word that can be used to enable, (or disable), individual trips. Refer to Chapter 10 “Trips and Fault Finding” for details of the value corresponding to each trip.

0763 **Active 1 - 32**

A 32-bit word that indicates which trip sources are active. For example, the HEATSINK OVERTEMP may remain true for some time after the initial fault is reported.

The Active value shows active trip sources even if the corresponding trip is not enabled in “Enabled 1-32”.

Refer to Chapter 10 “Trips and Fault Finding” for details of the value corresponding to each trip.

0829 **Warnings 1 - 32**

A 32-bit word that indicates trip sources that are close to a fault condition. For example, the heat sink fault monitoring firmware reports a HEATSINK OVERTEMP warning when the heat sink temperature gets close to the heat sink fault level.

The Warnings value is not affected by the trip enable mask, “Enabled 1-32”.

Refer to Chapter 10 “Trips and Fault Finding” for details of the value corresponding to each trip.

D-98 Parameter Reference

Voltage Control

Parameters::Motor Control::Voltage Control

Designed for VOLTS/Hz motor Control Mode.

This function allows the motor output volts to be controlled in the presence of dc link voltage variations. This is achieved by controlling the level of PWM modulation as a function of measured dc link volts. The dc link volts may vary either due to supply variations or regenerative braking by the motor.

Three control modes are available, None, Fixed and Automatic.

PNO	Parameter Descriptions
<u>0371</u>	Terminal Voltage Mode Selection of voltage control mode
<u>0374</u>	Motor Base Volts Scale of the output voltage

Web Server

Parameters::Base Comms::Web Server

Advanced Setup::Environment

Advanced Setup::Communications::Base Ethernet

Refer to Chapter 12 “Ethernet”.

D-100 Parameter Reference

Write Process

Advanced Setup::Communications::Option Parameters::Option Comms::Write Process

Refer to the following Technical Manuals:

Product Code	Description	Part Number
7003-PB-00	Profibus DP-V1	HA501837U001
7003-PN-00	PROFINET IO	HA501838U001
7003-DN-00	DeviceNet	HA501840U001
7003-CN-00	ControlNet	HA501936U001
7003-CB-00	CANopen	HA501841U001
7003-IP-00	EtherNet IP	HA501842U001
7003-EC-00	EtherCAT	HA501938U001
7003-RS-00	Modbus RTU	HA501839U001
7003-IM-00	Modbus TCP	HA501937U001
7003-CC-00	CC-LINK	HA501941U001

Parameter Table

This table is a complete list of all the parameters in the AC30V.

PNO: The parameter number, a unique identifier for this parameter.

Name: The parameter's name as it appears on the GKP and web page.

Path(s): The navigation path(s) to this parameter on the GKP and web page.

Type: The data type of the parameter.

Data Type	Description
BOOL	A Boolean quantity representing FALSE or TRUE. (A zero value is FALSE).
SINT	A signed integer with a maximum range of -128 to +127.
INT	A signed integer with a maximum range of -32768 to +32767
DINT	A signed integer with a maximum range of -2147483648 to +2147483647
USINT ⁽¹⁾	An unsigned integer with a maximum range of 0 to 255
UINT	An unsigned integer with a maximum range of 0 to 65535
UDINT	An unsigned integer with a maximum range of 0 to 4294967295
REAL	A 32-bit floating point conforming to IEEE-754
TIME	A duration with a resolution of 1 ms and a maximum range of 0.000s to 4294967.295s, (about 50 days)
DATE	Date with a maximum range of 1 st Jan 1970 to 2037.
TIME_OF_DAY	Time of day
DATE_AND_TIME	Date and time of day with a maximum range of 1 st Jan 1970 to 2037
STRING	String
BYTE	Bit string length 8
WORD ⁽²⁾	Bit string length 16
DWORD ⁽²⁾	Bit string length 32

(1) Some parameters of type USINT use discrete integer values to enumerate given states. For example; PNO 0001, the analog input hardware configuration may be set to 0, 1, 2 or 3 corresponding to the supported ranges. Such parameters have the available selections shown in the Range column.

(2) Some Bit string parameters have the individual bits within the word assigned independently to separate functionality. For example PNO 0005 presents the state of all digital inputs in one 16-bit word. The bits may be individually accessed on the GKP and webpage by expanding the parameter. Each individual feature may be accessed as a Boolean via any fieldbus communications link by referencing the dedicated PNO.

Default: The default value of the parameter.

Range: The minimum and maximum values for this parameter. This column is also used to detail the available selection for enumerated integer types and named bits in bit string data types.

Units: The units text displayed with this parameter value.

D-102 Parameter Reference

WQ: The write qualifier.

ALWAYS	The parameter has no write restrictions
STOPPED	The parameter is only writable when the motor is not being controlled
CONFIG	The parameter may only be written when the drive is in CONFIGURATION mode (NOT READY TO SWITCH ON)
NEVER	The parameter is monitor only

View: Indicates when the parameter is visible on the GKP or the Web page.

Parameters that are not relevant to the current drive's configuration may be hidden regardless of the View level.

OPERATOR	The parameter is always visible.
TECHNICIAN	The parameter is visible when the view level is set to OPERATOR or TECHNICIAN
ENGINEER	The parameter is visible when the view level is set to OPERATOR, TECHNICIAN or ENGINEER

Mbus: The Modbus register number corresponding the this PNO.

Notes:

1. The parameter is automatically saved before power down
2. Input parameter is not saved.
3. Output parameter is saved.
4. Parameter is hidden depending on the drive configuration.
5. Parameter availability depends on the application selected.

Parameter Reference D-103

PNO	Name	Path(s)	Type	Default	Range	Units	WQ	View	Notes	Mbus
0001	Anin 01 Type	Advanced Setup::Inputs and Outputs Parameters::Inputs And Outputs::IO Configure	USINT (enum)	0	0:-10..10V 1:0..10V 2:0..20MA 3:4..20MA		ALWAYS	OPERATOR		00529
0002	Anin 02 Type	Same as PNO 1	USINT (enum)	0	0:-10..10V 1:0..10V		ALWAYS	OPERATOR		00531
0003	Anout 01 Type	Same as PNO 1	USINT (enum)	0	Same as PNO 2		ALWAYS	OPERATOR		00533
0004	Anout 02 Type	Same as PNO 1	USINT (enum)	1	1:0..10V 2:0..20MA 3:4..20MA		ALWAYS	OPERATOR		00535
0005	Digin Value	Advanced Monitor::Inputs and Outputs Parameters::Inputs And Outputs::IO Values	WORD (bitfield)		0:Digin 01 1:Digin 02 2:Digin 03 3:Digin 04 4:Digin 05 5:Digin 06 6:Digin 07 7:STO Inactive 8:Digin 11 9:Digin 12 10:Digin 13 11:Digin 14		NEVER	OPERATOR		00537
0006	Digin Value.Digin 01	Same as PNO 5	BOOL				NEVER	OPERATOR		00539
0007	Digin Value.Digin 02	Same as PNO 5	BOOL				NEVER	OPERATOR		00541
0008	Digin Value.Digin 03	Same as PNO 5	BOOL				NEVER	OPERATOR		00543
0009	Digin Value.Digin 04	Same as PNO 5	BOOL				NEVER	OPERATOR		00545
0010	Digin Value.Digin 05	Same as PNO 5	BOOL				NEVER	OPERATOR		00547
0011	Digin Value.Digin 06	Same as PNO 5	BOOL				NEVER	OPERATOR		00549
0012	Digin Value.Digin 07	Same as PNO 5	BOOL				NEVER	OPERATOR		00551
0013	Digin Value.STO Inactive	Same as PNO 5	BOOL				NEVER	OPERATOR		00553
0014	Digin Value.Digin 11	Same as PNO 5	BOOL				NEVER	OPERATOR		00555
0015	Digin Value.Digin 12	Same as PNO 5	BOOL				NEVER	OPERATOR		00557
0016	Digin Value.Digin 13	Same as PNO 5	BOOL				NEVER	OPERATOR		00559
0017	Digin Value.Digin 14	Same as PNO 5	BOOL				NEVER	OPERATOR		00561
0022	Digout Value	Same as PNO 5	WORD (bitfield)	0000	0:Digout 01 1:Digout 02 2:Digout 03 3:Digout 04 4:Relay 01 5:Relay 02 8:Digout 11 9:Digout 12 10:Digout 13 11:Digout 14 14:Relay 11 15:Relay 12		ALWAYS	OPERATOR	2	00571
0023	Digout Value.Digout 01	Same as PNO 5	BOOL	FALSE			ALWAYS	OPERATOR	2	00573
0024	Digout Value.Digout 02	Same as PNO 5	BOOL	FALSE			ALWAYS	OPERATOR	2	00575
0025	Digout Value.Digout 03	Same as PNO 5	BOOL	FALSE			ALWAYS	OPERATOR	2	00577
0026	Digout Value.Digout 04	Same as PNO 5	BOOL	FALSE			ALWAYS	OPERATOR	2	00579
0027	Digout Value.Relay 01	Same as PNO 5	BOOL	FALSE			ALWAYS	OPERATOR	2	00581
0028	Digout Value.Relay 02	Same as PNO 5	BOOL	FALSE			ALWAYS	OPERATOR	2	00583
0031	Digout Value.Digout 11	Same as PNO 5	BOOL	FALSE			ALWAYS	OPERATOR	2	00589
0032	Digout Value.Digout 12	Same as PNO 5	BOOL	FALSE			ALWAYS	OPERATOR	2	00591
0033	Digout Value.Digout 13	Same as PNO 5	BOOL	FALSE			ALWAYS	OPERATOR	2	00593

D-104 Parameter Reference

PNO	Name	Path(s)	Type	Default	Range	Units	WQ	View	Notes	MBus
0034	Digout Value.Digout 14	Same as PNO 5	BOOL	FALSE			ALWAYS	OPERATOR	2	00595
0037	Digout Value.Relay 11	Same as PNO 5	BOOL	FALSE			ALWAYS	OPERATOR	2	00601
0038	Digout Value.Relay 12	Advanced Monitor::Inputs and Outputs Parameters::Inputs And Outputs::IO Values	BOOL	FALSE			ALWAYS	OPERATOR	2	00603
0039	Anin 01 Value	Same as PNO 38	REAL	x.x	-100.0 to 100.0	%	NEVER	OPERATOR		00605
0040	Anin 01 Break	Parameters::Inputs And Outputs::IO Values	BOOL				NEVER	OPERATOR	4	00607
0041	Anin 02 Value	Same as PNO 38	REAL	x.x	-100.0 to 100.0	%	NEVER	OPERATOR		00609
0042	Anout 01 Value	Same as PNO 38	REAL	0.00	-100.00 to 100.00	%	ALWAYS	OPERATOR	2	00611
0043	Anout 02 Value	Same as PNO 38	REAL	0.00	0.00 to 100.00	%	ALWAYS	OPERATOR	2	00613
0044	Comms Required	Advanced Setup::Communications::Option Parameters::Option Comms::Comms	USINT (enum)	1	1:NONE 4:CANOPEN 7:DEVICENET 9:ETHERNET IP 10:MODBUS RTU 12:PROFIBUS DPV1 13:PROFINET IO		CONFIG	TECHNICIAN		00615
0045	Comms Fitted	Advanced Monitor::Communications::Option Parameters::Option Comms::Comms	USINT (enum)		0:UNKNOWN 1:NONE 2:BACNET IP 3:BACNET MSTP 4:CANOPEN 5:CC LINK 6:CONTROLNET 7:DEVICENET 8:ETHERCAT 9:ETHERNET IP 10:MODBUS RTU 11:MODBUS TCP 12:PROFIBUS DPV1 13:PROFINET IO		NEVER	OPERATOR		00617
0046	Comms State	Parameters::Option Comms::Comms	USINT (enum)		0:SETUP 1:NW INIT 2:WAIT PROCESS 3:IDLE 4:PROCESS ACTIVE 5:ERROR 6:RESERVED 7:EXCEPTION 8:NONE		NEVER	ENGINEER		00619
0047	Comms Supervised	Same as PNO 45	BOOL				NEVER	OPERATOR	4	00621
0048	Comms Trip Enable	Same as PNO 44	BOOL	TRUE			ALWAYS	TECHNICIAN	4	00623
0049	Comms Module Version	Same as PNO 45	DWORD				NEVER	TECHNICIAN		00625
0050	Comms Module Serial	Same as PNO 45	DWORD				NEVER	TECHNICIAN		00627
0051	Comms Diagnostic	Same as PNO 45	USINT (enum)		0:NONE 1:HARDWARE MISMATCH 2:INVALID CONFIGURATION 3:MAPPING FAILED 4:EXCEPTION 5:UNSUPPORTED OPTION		NEVER	OPERATOR		00629
0052	Comms Diagnostic Code	Same as PNO 45	DWORD				NEVER	OPERATOR		00631
0053	Comms Exception	Same as PNO 45	BYTE				NEVER	TECHNICIAN	4	00633
0054	Comms Net Exception	Same as PNO 45	BYTE				NEVER	TECHNICIAN	4	00635
0055	Read Mapping	Advanced Setup::Communications::Option Parameters::Option Comms::Read Process	ARRAY[0..15]				CONFIG	TECHNICIAN		00637
0056	Read Mapping[0]	Same as PNO 55	UINT	0627	0000 to 2039		CONFIG	TECHNICIAN	4	00639
0057	Read Mapping[1]	Same as PNO 55	UINT	0681	0000 to 2039		CONFIG	TECHNICIAN	4	00641
0058	Read Mapping[2]	Same as PNO 55	UINT	0000	0000 to 2039		CONFIG	TECHNICIAN	4	00643

Parameter Reference D-105

PNO	Name	Path(s)	Type	Default	Range	Units	WQ	View	Notes	MBus
0059	Read Mapping[3]	Same as PNO 55	UINT	0000	0000 to 2039		CONFIG	TECHNICIAN	4	00645
0060	Read Mapping[4]	Same as PNO 55	UINT	0000	0000 to 2039		CONFIG	TECHNICIAN	4	00647
0061	Read Mapping[5]	Same as PNO 55	UINT	0000	0000 to 2039		CONFIG	TECHNICIAN	4	00649
0062	Read Mapping[6]	Same as PNO 55	UINT	0000	0000 to 2039		CONFIG	TECHNICIAN	4	00651
0063	Read Mapping[7]	Same as PNO 55	UINT	0000	0000 to 2039		CONFIG	TECHNICIAN	4	00653
0064	Read Mapping[8]	Same as PNO 55	UINT	0000	0000 to 2039		CONFIG	TECHNICIAN	4	00655
0065	Read Mapping[9]	Same as PNO 55	UINT	0000	0000 to 2039		CONFIG	TECHNICIAN	4	00657
0066	Read Mapping[10]	Same as PNO 55	UINT	0000	0000 to 2039		CONFIG	TECHNICIAN	4	00659
0067	Read Mapping[11]	Same as PNO 55	UINT	0000	0000 to 2039		CONFIG	TECHNICIAN	4	00661
0068	Read Mapping[12]	Same as PNO 55	UINT	0000	0000 to 2039		CONFIG	TECHNICIAN	4	00663
0069	Read Mapping[13]	Same as PNO 55	UINT	0000	0000 to 2039		CONFIG	TECHNICIAN	4	00665
0070	Read Mapping[14]	Same as PNO 55	UINT	0000	0000 to 2039		CONFIG	TECHNICIAN	4	00667
0071	Read Mapping[15]	Same as PNO 55	UINT	0000	0000 to 2039		CONFIG	TECHNICIAN	4	00669
0120	Write Mapping	Advanced Setup::Communications::Option Parameters::Option Comms::Write Process	ARRAY[0..15]				CONFIG	TECHNICIAN		00767
0121	Write Mapping[0]	Same as PNO 120	UINT	0661	0000 to 2039		CONFIG	TECHNICIAN	4	00769
0122	Write Mapping[1]	Same as PNO 120	UINT	0395	0000 to 2039		CONFIG	TECHNICIAN	4	00771
0123	Write Mapping[2]	Same as PNO 120	UINT	0000	0000 to 2039		CONFIG	TECHNICIAN	4	00773
0124	Write Mapping[3]	Same as PNO 120	UINT	0000	0000 to 2039		CONFIG	TECHNICIAN	4	00775
0125	Write Mapping[4]	Same as PNO 120	UINT	0000	0000 to 2039		CONFIG	TECHNICIAN	4	00777
0126	Write Mapping[5]	Same as PNO 120	UINT	0000	0000 to 2039		CONFIG	TECHNICIAN	4	00779
0127	Write Mapping[6]	Same as PNO 120	UINT	0000	0000 to 2039		CONFIG	TECHNICIAN	4	00781
0128	Write Mapping[7]	Same as PNO 120	UINT	0000	0000 to 2039		CONFIG	TECHNICIAN	4	00783
0129	Write Mapping[8]	Same as PNO 120	UINT	0000	0000 to 2039		CONFIG	TECHNICIAN	4	00785
0130	Write Mapping[9]	Same as PNO 120	UINT	0000	0000 to 2039		CONFIG	TECHNICIAN	4	00787
0131	Write Mapping[10]	Same as PNO 120	UINT	0000	0000 to 2039		CONFIG	TECHNICIAN	4	00789
0132	Write Mapping[11]	Same as PNO 120	UINT	0000	0000 to 2039		CONFIG	TECHNICIAN	4	00791
0133	Write Mapping[12]	Same as PNO 120	UINT	0000	0000 to 2039		CONFIG	TECHNICIAN	4	00793
0134	Write Mapping[13]	Same as PNO 120	UINT	0000	0000 to 2039		CONFIG	TECHNICIAN	4	00795
0135	Write Mapping[14]	Same as PNO 120	UINT	0000	0000 to 2039		CONFIG	TECHNICIAN	4	00797
0136	Write Mapping[15]	Same as PNO 120	UINT	0000	0000 to 2039		CONFIG	TECHNICIAN	4	00799
0185	Comms Event Code	Parameters::Option Comms::Event	BYTE	00			ALWAYS	ENGINEER	2,4	00897
0186	Comms Event Active	Advanced Monitor::Communications::Option Parameters::Option Comms::Event	BOOL				NEVER	OPERATOR	4	00899
0187	Comms Event Set	Parameters::Option Comms::Event	BOOL	FALSE			ALWAYS	ENGINEER	2,4	00901
0188	Comms Event Clear	Parameters::Option Comms::Event	BOOL	FALSE			ALWAYS	ENGINEER	2,4	00903
0189	Option MAC Address	Advanced Monitor::Communications::Option Parameters::Option Comms::Option Ethernet	STRING				NEVER	TECHNICIAN	4	00905
0195	Option IP Address	Same as PNO 189	DWORD (IP addr)				NEVER	OPERATOR	4	00917
0196	Option Subnet Mask	Same as PNO 189	DWORD (IP addr)				NEVER	OPERATOR	4	00919
0197	Option Gateway	Same as PNO 189	DWORD (IP addr)				NEVER	OPERATOR	4	00921
0198	Option DHCP Enabled	Same as PNO 189	BOOL				NEVER	TECHNICIAN	4	00923
0199	Address Assignment	Advanced Setup::Communications::Option Parameters::Option Comms::Option Ethernet	USINT (enum)	0	0:FIXED 1:EXTERNAL 2:DHCP		CONFIG	TECHNICIAN	4	00925
0200	Fixed IP Address	Same as PNO 199	DWORD (IP addr)	000.000.000.000			CONFIG	TECHNICIAN	4	00927
0201	Fixed Subnet Mask	Same as PNO 199	DWORD (IP addr)	000.000.000.000			CONFIG	TECHNICIAN	4	00929
0202	Fixed Gateway Address	Same as PNO 199	DWORD (IP addr)	000.000.000.000			CONFIG	TECHNICIAN	4	00931
0203	Option Web Enable	Same as PNO 199	BOOL	TRUE			CONFIG	TECHNICIAN	4	00933
0204	Web Parameters Enable	Same as PNO 199	BOOL	TRUE			CONFIG	TECHNICIAN	4	00935

D-106 Parameter Reference

PNO	Name	Path(s)	Type	Default	Range	Units	WQ	View	Notes	Mbus
0205	Option FTP Enable	Same as PNO 199	BOOL	TRUE			CONFIG	ENGINEER	4	00937
0206	Option FTP Admin Mode	Same as PNO 199	BOOL	TRUE			CONFIG	ENGINEER	4	00939
0207	IPConfig Enable	Same as PNO 199	BOOL	TRUE			CONFIG	ENGINEER	4	00941
0208	BACnet IP State	Advanced Monitor::Communications::Option Parameters::Option Comms::BACnet IP	USINT (enum)		Same as PNO 46		NEVER	OPERATOR	4	00943
0209	BACnet IP Device ID	Advanced Setup::Communications::Option Parameters::Option Comms::BACnet IP	UDINT	0	0 to 4194302		CONFIG	TECHNICIAN	4	00945
0210	BACnet IP Timeout	Same as PNO 209	TIME	3.000	0.000 to 65.000	s	CONFIG	TECHNICIAN	4	00947
0211	CANopen State	Advanced Monitor::Communications::Option Parameters::Option Comms::CANopen	USINT (enum)		0:SETUP 1:NW INIT 2:PRE-OPERATIONAL 3:STOP 4:OPERATIONAL 5:BUS OFF 6:RESERVED 7:EXCEPTION 8:NONE		NEVER	OPERATOR	4	00949
0212	CANopen Node Address	Advanced Setup::Communications::Option Parameters::Option Comms::CANopen	USINT	1	1 to 127		CONFIG	TECHNICIAN	4	00951
0213	CANopen Baud Rate	Same as PNO 212	USINT (enum)	9	0:10 KBPS 1:20 KBPS 2:50 KBPS 3:100 KBPS 4:125 KBPS 5:250 KBPS 6:500 KBPS 7:800 KBPS 8:1000 KBPS 9:AUTO		CONFIG	TECHNICIAN	4	00953
0214	ControlNet State	Advanced Monitor::Communications::Option Parameters::Option Comms::ControlNet	USINT (enum)		0:SETUP 1:NW INIT 2:WAITING TO CONNECT 3:CONNECTION IDLE 4:CONNECTION ACTIVE 5:ERROR 6:RESERVED 7:EXCEPTION 8:NONE		NEVER	OPERATOR	4	00955
0215	ControlNet MAC ID	Advanced Setup::Communications::Option Parameters::Option Comms::ControlNet	USINT	0	0 to 99		CONFIG	TECHNICIAN	4	00957
0216	CNet Producing Inst	Same as PNO 215	WORD	0064			CONFIG	TECHNICIAN	4	00959
0217	CNet Consuming Inst	Same as PNO 215	WORD	0096			CONFIG	TECHNICIAN	4	00961
0218	DeviceNet State	Advanced Monitor::Communications::Option Parameters::Option Comms::DeviceNet	USINT (enum)		Same as PNO 214		NEVER	OPERATOR	4	00963
0219	DeviceNet MAC ID	Advanced Setup::Communications::Option Parameters::Option Comms::DeviceNet	USINT	0	0 to 63		CONFIG	TECHNICIAN	4	00965
0220	DeviceNet Baud Rate	Same as PNO 219	USINT (enum)	3	0:125 KBPS 1:250 KBPS 2:500 KBPS 3:AUTO		CONFIG	TECHNICIAN	4	00967
0221	DeviceNet Actual Baud	Same as PNO 218	USINT (enum)		Same as PNO 220		NEVER	OPERATOR	4	00969
0222	DNet Producing Inst	Same as PNO 219	WORD	0064			CONFIG	TECHNICIAN	4	00971
0223	DNet Consuming Inst	Same as PNO 219	WORD	0096			CONFIG	TECHNICIAN	4	00973

Parameter Reference D-107

PNO	Name	Path(s)	Type	Default	Range	Units	WQ	View	Notes	MBus
0224	EtherCAT State	Advanced Monitor::Communications::Option Parameters::Option Comms::EtherCAT	USINT (enum)		0:SETUP 1:NW INIT 2:INIT OR PREOP 3:SAFE OPERATIONAL 4:OPERATIONAL 5:ERROR 6:RESERVED 7:EXCEPTION 8:NONE		NEVER	OPERATOR	4	00975
0225	EtherNet IP State	Advanced Monitor::Communications::Option Parameters::Option Comms::EtherNet IP	USINT (enum)		Same as PNO 214		NEVER	OPERATOR	4	00977
0226	ENet Producing Inst	Advanced Setup::Communications::Option Parameters::Option Comms::EtherNet IP	WORD	0064			CONFIG	TECHNICIAN	4	00979
0227	ENet Consuming Inst	Same as PNO 226	WORD	0096			CONFIG	TECHNICIAN	4	00981
0228	Modbus RTU State	Advanced Monitor::Communications::Option Parameters::Option Comms::Modbus RTU	USINT (enum)		Same as PNO 46		NEVER	OPERATOR	4	00983
0229	Modbus Device Address	Advanced Setup::Communications::Option Parameters::Option Comms::Modbus RTU	USINT	1	1 to 247		CONFIG	TECHNICIAN	4	00985
0230	Modbus RTU Baud Rate	Same as PNO 229	USINT (enum)	4	0:1200 BPS 1:2400 BPS 2:4800 BPS 3:9600 BPS 4:19200 BPS 5:38400 BPS 6:57600 BPS 7:76800 BPS 8:115200 BPS		CONFIG	TECHNICIAN	4	00987
0231	Parity And Stop Bits	Same as PNO 229	USINT (enum)	0	0:EVEN, 1 STOP 1:ODD, 1 STOP 2:NONE, 2 STOP 3:NONE, 1 STOP		CONFIG	TECHNICIAN	4	00989
0232	High Word First RTU	Same as PNO 229	BOOL	FALSE			CONFIG	TECHNICIAN	4	00991
0233	Modbus RTU Timeout	Same as PNO 229	TIME	3.000	0.000 to 65.000	s	CONFIG	TECHNICIAN	4	00993
0234	Modbus TCP State	Advanced Monitor::Communications::Option Parameters::Option Comms::Modbus TCP	USINT (enum)		Same as PNO 46		NEVER	OPERATOR	4	00995
0235	High Word First TCP	Advanced Setup::Communications::Option Parameters::Option Comms::Modbus TCP	BOOL	FALSE			CONFIG	TECHNICIAN	4	00997
0236	Modbus TCP Timeout	Same as PNO 235	TIME	3.000	0.000 to 65.000	s	CONFIG	TECHNICIAN	4	00999
0237	Profibus State	Advanced Monitor::Communications::Option Parameters::Option Comms::Profibus	USINT (enum)		Same as PNO 46		NEVER	OPERATOR	4	01001
0238	Profibus Node Address	Advanced Setup::Communications::Option Parameters::Option Comms::Profibus	USINT	0	0 to 126		CONFIG	TECHNICIAN	4	01003
0239	PROFINET State	Advanced Monitor::Communications::Option Parameters::Option Comms::PROFINET IO	USINT (enum)		0:SETUP 1:NW INIT 2:WAITING TO CONNECT 3:STOP MODE 4:CONNECTED 5:ERROR 6:RESERVED 7:EXCEPTION 8:NONE		NEVER	OPERATOR	4	01005
0240	PROFINET Device Name	Same as PNO 239	STRING				NEVER	OPERATOR	4	01007
0249	Braking Enable	Parameters::Motor Control::Braking	BOOL	TRUE			ALWAYS	TECHNICIAN		01025
0251	Brake Resistance	Parameters::Motor Control::Braking	REAL	100.00	0.01 to 300.00	Ohms	ALWAYS	TECHNICIAN		01029
0252	Brake Rated Power	Parameters::Motor Control::Braking	REAL	0.10	0.10 to 510.00	kW	ALWAYS	TECHNICIAN		01031
0253	Brake Overrating	Parameters::Motor Control::Braking	REAL	25.00	1.00 to 40.00		ALWAYS	ENGINEER		01033
0254	Braking Active	Parameters::Motor Control::Braking	BOOL				NEVER	TECHNICIAN		01035

D-108 Parameter Reference

PNO	Name	Path(s)	Type	Default	Range	Units	WQ	View	Notes	MBus
0255	Autotune Enable	Advanced Setup::Motor Control::Autotune Parameters::Motor Control::Autotune	BOOL	FALSE			STOPPED	TECHNICIAN	2,4	01037
0256	Autotune Mode	Same as PNO 255	USINT (enum)	1	0:STATIONARY 1:ROTATING		STOPPED	TECHNICIAN	4	01039
0257	Autotune Test Disable	Same as PNO 255	WORD (bitfield)	0000	0:Stator Resistance 1:Leakage Inductance 2:Magnetising Current 3:Rotor Time Constant		STOPPED	TECHNICIAN	4	01041
0258	Autotune Test Disable.Stator Resistance	Same as PNO 255	BOOL	FALSE			STOPPED	TECHNICIAN	4	01043
0259	Autotune Test Disable.Leakage Inductance	Same as PNO 255	BOOL	FALSE			STOPPED	TECHNICIAN	4	01045
0260	Autotune Test Disable.Magnetising Current	Same as PNO 255	BOOL	FALSE			STOPPED	TECHNICIAN	4	01047
0261	Autotune Test Disable.Rotor Time Constant	Same as PNO 255	BOOL	FALSE			STOPPED	TECHNICIAN	4	01049
0274	Autotune Ramp Time	Same as PNO 255	TIME	10.000	1.000 to 1000.000	s	STOPPED	TECHNICIAN	4	01075
0305	Current Limit	Advanced Setup::Motor Control::Control and Type Parameters::Motor Control::Current Limit	REAL	150.0	0.0 to 300.0	%	ALWAYS	TECHNICIAN		01137
0307	Regen Limit Enable	Parameters::Motor Control::Current Limit	BOOL	TRUE			ALWAYS	ENGINEER	4	01141
0310	VHz Flying Start Enable	Parameters::Motor Control::Flycatching	BOOL	FALSE			ALWAYS	TECHNICIAN	4	01147
0311	VC Flying Start Enable	Parameters::Motor Control::Flycatching	BOOL	FALSE			ALWAYS	TECHNICIAN	4	01149
0312	Flying Start Mode	Parameters::Motor Control::Flycatching	USINT (enum)	0	0:ALWAYS 1:TRIP OR POWER UP 2:TRIP		ALWAYS	TECHNICIAN	4	01151
0313	Search Mode	Parameters::Motor Control::Flycatching	USINT (enum)	0	0:BIDIRECTIONAL 1:UNIDIRECTION		ALWAYS	TECHNICIAN	4	01153
0314	Search Volts	Parameters::Motor Control::Flycatching	REAL	9.0	0.0 to 100.0	%	ALWAYS	TECHNICIAN	4	01155
0315	Search Boost	Parameters::Motor Control::Flycatching	REAL	40.0	0.0 to 50.0	%	ALWAYS	TECHNICIAN	4	01157
0316	Search Time	Parameters::Motor Control::Flycatching	TIME	3.000	0.100 to 60.000	s	ALWAYS	TECHNICIAN	4	01159
0317	Min Search Speed	Parameters::Motor Control::Flycatching	REAL	5	0 to 500	Hz	ALWAYS	TECHNICIAN	4	01161
0318	Flying Reflux Time	Parameters::Motor Control::Flycatching	TIME	2.000	0.100 to 10.000	s	ALWAYS	TECHNICIAN	4	01163
0324	DC Inj Deflux Time	Parameters::Motor Control::Inj Braking	TIME	0.500	0.100 to 20.000	s	ALWAYS	TECHNICIAN	4	01175
0325	DC Inj Frequency	Parameters::Motor Control::Inj Braking	REAL	9	1 to 500	Hz	ALWAYS	TECHNICIAN	4	01177
0326	DC Inj Current Limit	Parameters::Motor Control::Inj Braking	REAL	100.0	50.0 to 150.0	%	ALWAYS	TECHNICIAN	4	01179
0327	DC Pulse Time	Parameters::Motor Control::Inj Braking	TIME	2.000	0.000 to 100.000	s	ALWAYS	TECHNICIAN	4	01181
0328	Final DC Pulse Time	Parameters::Motor Control::Inj Braking	TIME	1.000	0.000 to 10.000	s	ALWAYS	TECHNICIAN	4	01183
0329	DC Current Level	Parameters::Motor Control::Inj Braking	REAL	3.0	0.0 to 25.0	%	ALWAYS	TECHNICIAN	4	01185
0330	DC Inj Timeout	Parameters::Motor Control::Inj Braking	TIME	90.000	0.000 to 600.000	s	ALWAYS	TECHNICIAN	4	01187
0331	DC Inj Base Volts	Parameters::Motor Control::Inj Braking	REAL	100.00	0.00 to 115.47	%	ALWAYS	TECHNICIAN	4	01189
0332	100% Mot Current	Parameters::Motor Control::Motor Load	REAL	x.x	0.0 to 10000.0		NEVER	TECHNICIAN		01191
0333	Mot Inv Time Overl'd	Parameters::Motor Control::Motor Load	REAL	x.	0 to 500	%	NEVER	TECHNICIAN	4	01193
0334	Mot Inv Time Delay	Parameters::Motor Control::Motor Load	TIME		0.000 to 100000.000	s	NEVER	TECHNICIAN	4	01195
0335	Mot Inv Time Warning	Parameters::Motor Control::Motor Load	BOOL				NEVER	TECHNICIAN	4	01197
0336	Mot Inv Time Active	Parameters::Motor Control::Motor Load	BOOL				NEVER	TECHNICIAN	4	01199
0337	Mot Inv Time Output %	Parameters::Motor Control::Motor Load	REAL	x.x	0.0 to 500.0	%	NEVER	TECHNICIAN	4	01201
0338	Mot I2T TC	Parameters::Motor Control::Motor Load	TIME		0.000 to 1000000.000	s	NEVER	TECHNICIAN	4	01203
0339	Actual Mot I2T Output	Parameters::Motor Control::Motor Load	REAL	x.x	0.0 to 500.0	%	NEVER	TECHNICIAN	4	01205
0340	Mot I2T Active	Parameters::Motor Control::Motor Load	BOOL				NEVER	OPERATOR	4	01207
0341	Mot I2T Warning	Parameters::Motor Control::Motor Load	BOOL				NEVER	TECHNICIAN	4	01209
0342	Mot I2T Enable	Parameters::Motor Control::Motor Load	BOOL				NEVER	TECHNICIAN	4	01211
0343	100% Stk Current	Parameters::Motor Control::Stack Inv Time	REAL	x.x	0.0 to 10000.0	A	NEVER	TECHNICIAN		01213
0344	Long Overload Level	Parameters::Motor Control::Stack Inv Time	REAL	x.	0 to 200	%	NEVER	TECHNICIAN		01215
0345	Long Overload Time	Parameters::Motor Control::Stack Inv Time	TIME		0.000 to 100000.000	s	NEVER	TECHNICIAN		01217
0346	Short Overload Level	Parameters::Motor Control::Stack Inv Time	REAL	x.	0 to 200	%	NEVER	TECHNICIAN		01219
0347	Short Overload Time	Parameters::Motor Control::Stack Inv Time	TIME		0.000 to 10000.000	s	NEVER	TECHNICIAN		01221
0348	Inv Time Aiming Point	Parameters::Motor Control::Stack Inv Time	REAL	x.	0 to 200	%	NEVER	TECHNICIAN		01223
0349	Inv Time Output	Parameters::Motor Control::Stack Inv Time	REAL	x.	0 to 500	%	NEVER	TECHNICIAN		01225
0350	Inv Time Up Rate	Parameters::Motor Control::Stack Inv Time	TIME	5.000	0.000 to 120.000	s	STOPPED	ENGINEER		01227
0351	Inv Time Down Rate	Parameters::Motor Control::Stack Inv Time	TIME	5.000	0.000 to 120.000	s	STOPPED	ENGINEER		01229

Parameter Reference D-109

PNO	Name	Path(s)	Type	Default	Range	Units	WQ	View	Notes	Mbus
0352	Inv Time Warning	Parameters::Motor Control::Stack Inv Time	BOOL				NEVER	TECHNICIAN		01231
0353	Inv Time Active	Parameters::Motor Control::Stack Inv Time	BOOL				NEVER	TECHNICIAN		01233
0354	Slip Compensatn Enable	Parameters::Motor Control::Slip Compensation	BOOL	FALSE			ALWAYS	TECHNICIAN	4	01235
0356	SLP Motoring Limit	Parameters::Motor Control::Slip Compensation	REAL	150	0 to 600	RPM	ALWAYS	TECHNICIAN	4	01239
0357	SLP Regen Limit	Parameters::Motor Control::Slip Compensation	REAL	150	0 to 600	RPM	ALWAYS	TECHNICIAN	4	01241
0360	Slew Rate Enable	Parameters::Motor Control::Slew Rate	BOOL	TRUE			ALWAYS	TECHNICIAN		01247
0361	Slew Rate Accel Limit	Parameters::Motor Control::Slew Rate	REAL	500	1 to 1200	Hz/s	ALWAYS	TECHNICIAN		01249
0362	Slew Rate Decel Limit	Parameters::Motor Control::Slew Rate	REAL	500	1 to 1200	Hz/s	ALWAYS	TECHNICIAN		01251
0364	Stabilisation Enable	Parameters::Motor Control::Stabilisation	BOOL	TRUE			ALWAYS	TECHNICIAN	4	01255
0371	Terminal Voltage Mode	Parameters::Motor Control::Voltage Control	USINT (enum)	0	0:NONE 1:FIXED 2:AUTOMATIC		ALWAYS	TECHNICIAN	4	01269
0374	Motor Base Volts	Parameters::Motor Control::Voltage Control	REAL	100.00	0.00 to 115.47	%	ALWAYS	TECHNICIAN	4	01275
0380	Power kW	Advanced Monitor::Energy Meter Parameters::Motor Control::Energy Meter	REAL	x.xx	0.00 to 1000000.00	kW	NEVER	TECHNICIAN		01287
0381	Power HP	Same as PNO 380	REAL	x.xx	0.00 to 1000000.00	HP	NEVER	TECHNICIAN		01289
0382	Reactive Power	Same as PNO 380	REAL	x.xx	0.00 to 1000000.00	kVA _r	NEVER	TECHNICIAN		01291
0383	Energy kWh	Same as PNO 380	REAL	x.xx	0.00 to 10000000.00	kWh	NEVER	TECHNICIAN	1	01293
0385	Power Factor Est	Same as PNO 380	REAL	x.xx	0.00 to 1.00		NEVER	TECHNICIAN		01297
0386	Power Factor Angle Est	Parameters::Motor Control::Energy Meter	REAL	x.xx	0.00 to 90.00	deg	NEVER	TECHNICIAN		01299
0389	Reset Energy Meter	Parameters::Motor Control::Energy Meter	BOOL	FALSE			ALWAYS	TECHNICIAN	2	01305
0390	Duty Selection	Advanced Setup::Motor Control::Control and Type Parameters::Motor Control::Feedbacks	USINT (enum)	1	0:HEAVY DUTY 1:NORMAL DUTY		STOPPED	TECHNICIAN		01307
0392	DC Link Voltage	Advanced Monitor::Motor and Drive Parameters::Motor Control::Feedbacks	REAL	x.	0 to 1000	V	NEVER	TECHNICIAN		01311
0393	Actual Speed RPM	Same as PNO 392	REAL	x.xx	-30000.00 to 30000.00	RPM	NEVER	TECHNICIAN		01313
0394	Actual Speed Hz	Same as PNO 392	REAL	x.xx	-1500.00 to 1500.00	Hz	NEVER	TECHNICIAN		01315
0395	Actual Speed Percent	Control Screen Advanced Monitor::Motor and Drive Parameters::Motor Control::Feedbacks	REAL	x.xx	-200.00 to 200.00	%	NEVER	OPERATOR		01317
0396	DC Link Volt Filtered	Same as PNO 392	REAL	x.	0 to 1000	V	NEVER	TECHNICIAN		01319
0397	id	Parameters::Motor Control::Feedbacks	REAL	x.x	-500.0 to 500.0	%	NEVER	ENGINEER		01321
0398	iq	Parameters::Motor Control::Feedbacks	REAL	x.x	-500.0 to 500.0	%	NEVER	ENGINEER		01323
0399	Actual Torque	Same as PNO 392	REAL	x.x	-500.0 to 500.0	%	NEVER	TECHNICIAN		01325
0400	Actual Field Current	Same as PNO 392	REAL	x.x	-200.0 to 200.0	%	NEVER	TECHNICIAN		01327
0401	Motor Current Percent	Same as PNO 392	REAL	x.x	0.0 to 500.0	%	NEVER	TECHNICIAN		01329
0402	Motor Current	Same as PNO 392	REAL	x.x	0.0 to 2000.0	A	NEVER	TECHNICIAN		01331
0403	100% Stack Current A	Parameters::Motor Control::Feedbacks	REAL	x.x	0.0 to 500.0	A	NEVER	TECHNICIAN		01333
0404	Stack Current (%)	Parameters::Motor Control::Feedbacks	REAL	x.	0 to 500	%	NEVER	TECHNICIAN	3	01335
0405	Motor Terminal Volts	Same as PNO 392	REAL	x.	0 to 1000	V	NEVER	TECHNICIAN		01337
0406	CM Temperature	Same as PNO 392	REAL	x.x	-25.0 to 200.0	C	NEVER	ENGINEER		01339
0407	Heatsink Temperature	Same as PNO 392	REAL	x.x	-25.0 to 200.0	C	NEVER	ENGINEER		01341
0408	Elec Rotor Speed	Parameters::Motor Control::Feedbacks	REAL	x.x	-1500.0 to 1500.0	Hz	NEVER	OPERATOR		01343
0409	Heatsink OT Trip	Parameters::Motor Control::Feedbacks	REAL	x.x	0.0 to 200.0	C	NEVER	OPERATOR		01345
0410	Heatsink OT Warning	Parameters::Motor Control::Feedbacks	REAL	x.x	0.0 to 200.0	C	NEVER	OPERATOR		01347
0411	Heatsink Hot Warning	Parameters::Motor Control::Feedbacks	REAL	x.x	0.0 to 200.0	C	NEVER	OPERATOR		01349
0412	Stack Frequency	Parameters::Motor Control::Pattern Generator	REAL	4.00	2.00 to 16.00	kHz	ALWAYS	ENGINEER		01351
0413	Random Pattern IM	Parameters::Motor Control::Pattern Generator	BOOL	TRUE			STOPPED	ENGINEER	4	01353
0414	Deflux Delay	Parameters::Motor Control::Pattern Generator	TIME	1.000	0.000 to 10.000	s	STOPPED	ENGINEER		01355
0415	Positive Torque Lim	Parameters::Motor Control::Torque Limit	REAL	150.0	-300.0 to 300.0	%	ALWAYS	TECHNICIAN		01357
0416	Negative Torque Lim	Parameters::Motor Control::Torque Limit	REAL	-150.0	-300.0 to 300.0	%	ALWAYS	TECHNICIAN		01359
0417	Main Torque Lim	Advanced Setup::Motor Control::Control and Type Parameters::Motor Control::Torque Limit	REAL	150.0	0.0 to 300.0	%	ALWAYS	TECHNICIAN		01361
0418	Fast Stop Torque Lim	Parameters::Motor Control::Torque Limit	REAL	150.0	0.0 to 300.0	%	ALWAYS	TECHNICIAN		01363
0419	Symmetric Torque Lim	Parameters::Motor Control::Torque Limit	BOOL	FALSE			ALWAYS	TECHNICIAN		01365

D-110 Parameter Reference

PNO	Name	Path(s)	Type	Default	Range	Units	WQ	View	Notes	MBus
0420	Actual Pos Torque Lim	Advanced Monitor::Motor and Drive Parameters::Motor Control::Torque Limit	REAL	x.x	-500.0 to 500.0	%	NEVER	TECHNICIAN		01367
0421	Actual Neg Torque Lim	Same as PNO 420	REAL	x.x	-500.0 to 500.0	%	NEVER	TECHNICIAN		01369
0422	VHz Shape	Advanced Setup::Motor Control::Control and Type Parameters::Motor Control::Fluxing VHz	USINT (enum)	0	0:LINEAR LAW 1:FAN LAW 2:USER DEFINED		STOPPED	TECHNICIAN	4	01371
0423	VHz User Freq	Parameters::Motor Control::Fluxing VHz	ARRAY[0..10]				STOPPED	ENGINEER		01373
0424	VHz User Freq[0]	Parameters::Motor Control::Fluxing VHz	REAL	0.0	0.0 to 100.0	%	STOPPED	ENGINEER	4	01375
0425	VHz User Freq[1]	Parameters::Motor Control::Fluxing VHz	REAL	10.0	0.0 to 100.0	%	STOPPED	ENGINEER	4	01377
0426	VHz User Freq[2]	Parameters::Motor Control::Fluxing VHz	REAL	20.0	0.0 to 100.0	%	STOPPED	ENGINEER	4	01379
0427	VHz User Freq[3]	Parameters::Motor Control::Fluxing VHz	REAL	30.0	0.0 to 100.0	%	STOPPED	ENGINEER	4	01381
0428	VHz User Freq[4]	Parameters::Motor Control::Fluxing VHz	REAL	40.0	0.0 to 100.0	%	STOPPED	ENGINEER	4	01383
0429	VHz User Freq[5]	Parameters::Motor Control::Fluxing VHz	REAL	50.0	0.0 to 100.0	%	STOPPED	ENGINEER	4	01385
0430	VHz User Freq[6]	Parameters::Motor Control::Fluxing VHz	REAL	60.0	0.0 to 100.0	%	STOPPED	ENGINEER	4	01387
0431	VHz User Freq[7]	Parameters::Motor Control::Fluxing VHz	REAL	70.0	0.0 to 100.0	%	STOPPED	ENGINEER	4	01389
0432	VHz User Freq[8]	Parameters::Motor Control::Fluxing VHz	REAL	80.0	0.0 to 100.0	%	STOPPED	ENGINEER	4	01391
0433	VHz User Freq[9]	Parameters::Motor Control::Fluxing VHz	REAL	90.0	0.0 to 100.0	%	STOPPED	ENGINEER	4	01393
0434	VHz User Freq[10]	Parameters::Motor Control::Fluxing VHz	REAL	100.0	0.0 to 100.0	%	STOPPED	ENGINEER	4	01395
0435	VHz User Volts	Parameters::Motor Control::Fluxing VHz	ARRAY[0..10]				STOPPED	ENGINEER		01397
0436	VHz User Volts[0]	Parameters::Motor Control::Fluxing VHz	REAL	0.0	0.0 to 100.0	%	STOPPED	ENGINEER	4	01399
0437	VHz User Volts[1]	Parameters::Motor Control::Fluxing VHz	REAL	10.0	0.0 to 100.0	%	STOPPED	ENGINEER	4	01401
0438	VHz User Volts[2]	Parameters::Motor Control::Fluxing VHz	REAL	20.0	0.0 to 100.0	%	STOPPED	ENGINEER	4	01403
0439	VHz User Volts[3]	Parameters::Motor Control::Fluxing VHz	REAL	30.0	0.0 to 100.0	%	STOPPED	ENGINEER	4	01405
0440	VHz User Volts[4]	Parameters::Motor Control::Fluxing VHz	REAL	40.0	0.0 to 100.0	%	STOPPED	ENGINEER	4	01407
0441	VHz User Volts[5]	Parameters::Motor Control::Fluxing VHz	REAL	50.0	0.0 to 100.0	%	STOPPED	ENGINEER	4	01409
0442	VHz User Volts[6]	Parameters::Motor Control::Fluxing VHz	REAL	60.0	0.0 to 100.0	%	STOPPED	ENGINEER	4	01411
0443	VHz User Volts[7]	Parameters::Motor Control::Fluxing VHz	REAL	70.0	0.0 to 100.0	%	STOPPED	ENGINEER	4	01413
0444	VHz User Volts[8]	Parameters::Motor Control::Fluxing VHz	REAL	80.0	0.0 to 100.0	%	STOPPED	ENGINEER	4	01415
0445	VHz User Volts[9]	Parameters::Motor Control::Fluxing VHz	REAL	90.0	0.0 to 100.0	%	STOPPED	ENGINEER	4	01417
0446	VHz User Volts[10]	Parameters::Motor Control::Fluxing VHz	REAL	100.0	0.0 to 100.0	%	STOPPED	ENGINEER	4	01419
0447	Fixed Boost	Same as PNO 422	REAL	0.0	0.0 to 5.0	%	ALWAYS	TECHNICIAN	4	01421
0448	Auto Boost	Parameters::Motor Control::Fluxing VHz	REAL	0.0	0.0 to 25.0	%	ALWAYS	TECHNICIAN	4	01423
0450	Acceleration Boost	Parameters::Motor Control::Fluxing VHz	REAL	0.0	0.0 to 25.0	%	ALWAYS	TECHNICIAN	4	01427
0451	Energy Saving Enable	Parameters::Motor Control::Fluxing VHz	BOOL	FALSE			ALWAYS	TECHNICIAN	4	01429
0455	Rated Motor Current	Advanced Setup::Motor Control::Motor Nameplate Parameters::Motor Control::Motor Nameplate	REAL	1.00	0.00 to 10000.00	A	STOPPED	TECHNICIAN	4	01437
0456	Base Voltage	Same as PNO 455	REAL	400.00	0.00 to 1000.00	V	STOPPED	TECHNICIAN	4	01439
0457	Base Frequency	Same as PNO 455	REAL	50.00	0.00 to 1000.00	Hz	STOPPED	TECHNICIAN	4	01441
0458	Motor Poles	Same as PNO 455	INT	4	2 to 1000		STOPPED	TECHNICIAN	4	01443
0459	Nameplate Speed	Same as PNO 455	REAL	1420.00	0.00 to 30000.00	RPM	STOPPED	TECHNICIAN	4	01445
0460	Motor Power	Same as PNO 455	REAL	2.20	0.00 to 3000.00	kW	STOPPED	TECHNICIAN	4	01447
0461	Power Factor	Same as PNO 455	REAL	0.79	0.00 to 1.00		STOPPED	TECHNICIAN	4	01449
0464	100% Speed in RPM	Advanced Setup::Motor Control::Control and Type Parameters::Motor Control::Scale Setpoint	REAL	1500.0	0.0 to 20000.0	RPM	ALWAYS	TECHNICIAN		01455
0467	PMAC SVC Auto Values	Parameters::Motor Control::PMAC SVC	BOOL	TRUE			ALWAYS	TECHNICIAN	4	01461
0468	PMAC SVC LPF Speed Hz	Parameters::Motor Control::PMAC SVC	REAL	60.00	0.00 to 10000.00	Hz	ALWAYS	TECHNICIAN	4	01463
0469	PMAC SVC P Gain	Parameters::Motor Control::PMAC SVC	REAL	1.00	0.00 to 10000.00		ALWAYS	TECHNICIAN	4	01465
0470	PMAC SVC I Gain Hz	Parameters::Motor Control::PMAC SVC	REAL	20.00	0.00 to 10000.00	Hz	ALWAYS	TECHNICIAN	4	01467
0476	PMAC SVC Open Loop Strt	Parameters::Motor Control::PMAC SVC	BOOL	TRUE			ALWAYS	TECHNICIAN	4	01479
0477	PMAC SVC Start Time	Parameters::Motor Control::PMAC SVC	TIME	0.500	0.000 to 1000.000	s	ALWAYS	TECHNICIAN	4	01481
0478	PMAC SVC Start Cur	Parameters::Motor Control::PMAC SVC	REAL	10.0	0.0 to 200.0	%	ALWAYS	TECHNICIAN	4	01483
0479	PMAC SVC Start Speed	Parameters::Motor Control::PMAC SVC	REAL	5	0 to 200	%	ALWAYS	TECHNICIAN	4	01485
0484	Seq Stop Method VHz	Advanced Setup::Motor Control::Control and Type Parameters::Motor Control::Ramp	USINT (enum)	1	0:DISABLED VOLTAGE 1:RAMP 2:STOP RAMP 3:DC INJECTION		ALWAYS	TECHNICIAN	4	01495

Parameter Reference D-111

PNO	Name	Path(s)	Type	Default	Range	Units	WQ	View	Notes	MBus
0485	Ramp Type	Parameters::Motor Control::Ramp	USINT (enum)	0	0:LINEAR 1:S RAMP		ALWAYS	TECHNICIAN		01497
0486	Acceleration Time	Same as PNO 484	TIME	10.000	0.000 to 3000.000	s	ALWAYS	TECHNICIAN		01499
0487	Deceleration Time	Same as PNO 484	TIME	10.000	0.000 to 3000.000	s	ALWAYS	TECHNICIAN		01501
0488	Symmetric Mode	Parameters::Motor Control::Ramp	BOOL	FALSE			ALWAYS	TECHNICIAN		01503
0489	Symmetric Time	Parameters::Motor Control::Ramp	TIME	10.000	0.000 to 3000.000	s	ALWAYS	TECHNICIAN		01505
0490	Sramp Continuous	Parameters::Motor Control::Ramp	BOOL	FALSE			ALWAYS	TECHNICIAN		01507
0491	Sramp Acceleration	Parameters::Motor Control::Ramp	REAL	10.0	0.0 to 100.0	%/s ²	ALWAYS	OPERATOR		01509
0492	Sramp Deceleration	Parameters::Motor Control::Ramp	REAL	10.0	0.0 to 100.0	%/s ²	ALWAYS	TECHNICIAN		01511
0493	Sramp Jerk 1	Parameters::Motor Control::Ramp	REAL	10.0	0.0 to 100.0	%/s ³	ALWAYS	TECHNICIAN		01513
0494	Sramp Jerk 2	Parameters::Motor Control::Ramp	REAL	10.0	0.0 to 100.0	%/s ³	ALWAYS	TECHNICIAN		01515
0495	Sramp Jerk 3	Parameters::Motor Control::Ramp	REAL	10.0	0.0 to 100.0	%/s ³	ALWAYS	TECHNICIAN		01517
0496	Sramp Jerk 4	Parameters::Motor Control::Ramp	REAL	10.0	0.0 to 100.0	%/s ³	ALWAYS	TECHNICIAN		01519
0497	Ramp Hold	Parameters::Motor Control::Ramp	BOOL	FALSE			ALWAYS	TECHNICIAN		01521
0498	Ramping Active	Parameters::Motor Control::Ramp	BOOL				NEVER	TECHNICIAN		01523
0499	Ramp Spd Setpoint Input	Parameters::Motor Control::Ramp	REAL	x.x	-200.0 to 200.0	%	NEVER	TECHNICIAN		01525
0500	Ramp Speed Output	Parameters::Motor Control::Ramp	REAL	x.x	-200.0 to 200.0	%	NEVER	TECHNICIAN		01527
0501	Jog Setpoint	Parameters::Motor Control::Ramp	REAL	10.0	0.0 to 100.0	%	ALWAYS	TECHNICIAN		01529
0502	Jog Acceleration Time	Parameters::Motor Control::Ramp	TIME	1.000	0.000 to 3000.000	s	ALWAYS	TECHNICIAN		01531
0503	Jog Deceleration Time	Parameters::Motor Control::Ramp	TIME	1.000	0.000 to 3000.000	s	ALWAYS	TECHNICIAN		01533
0504	Stop Ramp Time	Same as PNO 484	TIME	10.000	0.000 to 600.000	s	ALWAYS	TECHNICIAN		01535
0505	Zero Speed Threshold	Parameters::Motor Control::Ramp	REAL	0.1	0.0 to 100.0	%	ALWAYS	TECHNICIAN		01537
0506	Zero Speed Stop Delay	Parameters::Motor Control::Ramp	TIME	0.500	0.000 to 30.000	s	ALWAYS	TECHNICIAN		01539
0507	Quickstop Time Limit	Parameters::Motor Control::Ramp	TIME	30.000	0.000 to 3000.000	s	ALWAYS	TECHNICIAN		01541
0508	Quickstop Ramp Time	Parameters::Motor Control::Ramp	TIME	0.100	0.000 to 600.000	s	ALWAYS	TECHNICIAN		01543
0509	Final Stop Rate	Parameters::Motor Control::Ramp	REAL	1200	1 to 4800	Hz/s	ALWAYS	TECHNICIAN		01545
0511	Motor Type	Advanced Setup::Motor Control::Control and Type Parameters::Motor Control::Control Mode	USINT (enum)	0	0:INDUCTION MOTOR 1:PMAC MOTOR		STOPPED	TECHNICIAN		01549
0512	Control Strategy	Same as PNO 511	USINT (enum)	0	0:VOLTS - HERTZ CONTROL 1:VECTOR CONTROL		STOPPED	TECHNICIAN	4	01551
0515	Speed Loop Pgain	Parameters::Motor Control::Spd Loop Settings	REAL	20.00	0.00 to 3000.00		ALWAYS	TECHNICIAN	4	01557
0516	Speed Loop I Time	Parameters::Motor Control::Spd Loop Settings	TIME	0.100	0.001 to 1.500	s	ALWAYS	TECHNICIAN	4	01559
0517	Speed Loop Int Defeat	Parameters::Motor Control::Spd Loop Settings	BOOL	FALSE			ALWAYS	TECHNICIAN	4	01561
0518	Speed Loop Int Preset	Parameters::Motor Control::Spd Loop Settings	REAL	0	-500 to 500		ALWAYS	TECHNICIAN	4	01563
0519	Spd Loop Dmd Filt TC	Parameters::Motor Control::Spd Loop Settings	REAL	0.0	0.0 to 15.0	ms	ALWAYS	TECHNICIAN	4	01565
0520	Spd Loop Fbk Filt TC	Parameters::Motor Control::Spd Loop Settings	REAL	1.0	0.0 to 15.0	ms	ALWAYS	TECHNICIAN	4	01567
0521	Spd Loop Aux Torq Dmd	Parameters::Motor Control::Spd Loop Settings	REAL	0.00	-300.00 to 300.00	%	ALWAYS	TECHNICIAN	4	01569
0523	Spd Loop Adapt Thres	Parameters::Motor Control::Spd Loop Settings	REAL	0.00	0.00 to 10.00	%	ALWAYS	TECHNICIAN	4	01573
0524	Spd Loop Adapt Pgain	Parameters::Motor Control::Spd Loop Settings	REAL	20.00	0.00 to 300.00		ALWAYS	TECHNICIAN	4	01575
0525	Spd Demand Pos Lim	Parameters::Motor Control::Spd Loop Settings	REAL	110.00	-110.00 to 110.00	%	ALWAYS	TECHNICIAN	4	01577
0526	Spd Demand Neg Lim	Parameters::Motor Control::Spd Loop Settings	REAL	-110.00	-110.00 to 110.00	%	ALWAYS	TECHNICIAN	4	01579
0527	Sel Torq Ctrl Only	Parameters::Motor Control::Spd Loop Settings	BOOL	FALSE			ALWAYS	TECHNICIAN	4	01581
0528	Direct Input Select	Parameters::Motor Control::Spd Direct Input	USINT (enum)	0	0:NONE 1:ANIN1 2:ANIN2		ALWAYS	TECHNICIAN	4	01583
0529	Direct Input Ratio	Parameters::Motor Control::Spd Direct Input	REAL	1.0000	-10.0000 to 10.0000		ALWAYS	TECHNICIAN	4	01585
0530	Direct Input Pos Lim	Parameters::Motor Control::Spd Direct Input	REAL	110.00	-110.00 to 110.00	%	ALWAYS	TECHNICIAN	4	01587
0531	Direct Input Neg Lim	Parameters::Motor Control::Spd Direct Input	REAL	-110.00	-110.00 to 110.00	%	ALWAYS	TECHNICIAN	4	01589
0533	Total Spd Demand RPM	Parameters::Motor Control::Spd Loop Diagnostics	REAL	x.xx	-30000.00 to 30000.00	RPM	NEVER	TECHNICIAN	4	01593
0534	Total Spd Demand %	Parameters::Motor Control::Spd Loop Diagnostics	REAL	x.xx	-200.00 to 200.00	%	NEVER	TECHNICIAN	4	01595
0535	Speed Loop Error	Parameters::Motor Control::Spd Loop Diagnostics	REAL	x.xx	-400.00 to 400.00	%	NEVER	TECHNICIAN	4	01597
0536	Speed PI Output	Parameters::Motor Control::Spd Loop Diagnostics	REAL	x.xx	-500.00 to 500.00	%	NEVER	TECHNICIAN	4	01599
0555	PMAC Max Speed	Advanced Setup::Motor Control::Motor Data PMAC Parameters::Motor Control::PMAC Motor Data	REAL	3000	0 to 30000	RPM	ALWAYS	TECHNICIAN	4	01637
0556	PMAC Max Current	Same as PNO 555	REAL	4.50	0.00 to 5000.00	A	ALWAYS	TECHNICIAN	4	01639
0557	PMAC Rated Current	Same as PNO 555	REAL	4.50	0.00 to 5000.00	A	ALWAYS	TECHNICIAN	4	01641

D-112 Parameter Reference

PNO	Name	Path(s)	Type	Default	Range	Units	WQ	View	Notes	Mbus
0558	PMAC Rated Torque	Same as PNO 555	REAL	4.50	0.00 to 30000.00	Nm	ALWAYS	TECHNICIAN	4	01643
0559	PMAC Motor Poles	Same as PNO 555	UINT	10	0 to 400		ALWAYS	TECHNICIAN	4	01645
0560	PMAC Back Emf Const KE	Same as PNO 555	REAL	60.0	0.0 to 30000.0	V	ALWAYS	TECHNICIAN	4	01647
0561	PMAC Winding Resistance	Same as PNO 555	REAL	6.580	0.000 to 50.000	Ohms	ALWAYS	TECHNICIAN	4	01649
0562	PMAC Winding Inductance	Same as PNO 555	REAL	20.00	0.00 to 1000.00	mH	ALWAYS	TECHNICIAN	4	01651
0563	PMAC Torque Const KT	Same as PNO 555	REAL	1.00	0.00 to 10000.00	Nm/A	ALWAYS	TECHNICIAN	4	01653
0564	PMAC Motor Inertia	Same as PNO 555	REAL	0.00100	0.00000 to 100.00000	kgm ²	ALWAYS	TECHNICIAN	4	01655
0565	PMAC Therm Time Const	Same as PNO 555	TIME	62.000	0.000 to 10000.000	s	ALWAYS	TECHNICIAN	4	01657
0568	Magnetising Current	Advanced Setup::Motor Control::Induction Motor Data Parameters::Motor Control::Induction Motor Data	REAL	1.00	0.00 to 10000.00	A	ALWAYS	TECHNICIAN	4	01663
0569	Rotor Time Constant	Same as PNO 568	TIME	0.100	0.005 to 100.000	s	ALWAYS	ENGINEER	4	01665
0570	Leakage Inductance	Same as PNO 568	REAL	1.000	0.000 to 1000.000	mH	ALWAYS	ENGINEER	4	01667
0571	Stator Resistance	Same as PNO 568	REAL	0.00	0.00 to 100.00	Ohms	ALWAYS	ENGINEER	4	01669
0572	Mutual Inductance	Same as PNO 568	REAL	100.00	0.00 to 10000.00	mH	ALWAYS	ENGINEER	4	01671
0591	Local	Parameters::Motor Control::Sequencing	BOOL	FALSE			ALWAYS	TECHNICIAN	1	01709
0592	Local Reference	Control Screen Parameters::Motor Control::Sequencing	REAL	0.00	0.00 to 100.00	%	ALWAYS	OPERATOR	4	01711
0610	App Control Word	Parameters::Motor Control::Sequencing	WORD (bitfield)	0000	0:SWITCH ON 1:ENABLE VOLTAGE 2:NOT QUICKSTOP 3:ENABLE OPERATION 7:RESET FAULT 12:USE JOG REFERENCE 13:REVERSE DIRECTION 14:AUTO INITIALISE 15:EVENT TRIGGERED OP		ALWAYS	ENGINEER	2	01747
0611	App Control Word.SWITCH ON	Parameters::Motor Control::Sequencing	BOOL	FALSE			ALWAYS	ENGINEER	2	01749
0612	App Control Word.ENABLE VOLTAGE	Parameters::Motor Control::Sequencing	BOOL	FALSE			ALWAYS	ENGINEER	2	01751
0613	App Control Word.NOT QUICKSTOP	Parameters::Motor Control::Sequencing	BOOL	FALSE			ALWAYS	ENGINEER	2	01753
0614	App Control Word.ENABLE OPERATION	Parameters::Motor Control::Sequencing	BOOL	FALSE			ALWAYS	ENGINEER	2	01755
0618	App Control Word.RESET FAULT	Parameters::Motor Control::Sequencing	BOOL	FALSE			ALWAYS	ENGINEER	2	01763
0623	App Control Word.USE JOG REFERENCE	Parameters::Motor Control::Sequencing	BOOL	FALSE			ALWAYS	ENGINEER	2	01773
0624	App Control Word.REVERSE DIRECTION	Parameters::Motor Control::Sequencing	BOOL	FALSE			ALWAYS	ENGINEER	2	01775
0625	App Control Word.AUTO INITIALISE	Parameters::Motor Control::Sequencing	BOOL	FALSE			ALWAYS	ENGINEER	2	01777
0626	App Control Word.EVENT TRIGGERED OP	Parameters::Motor Control::Sequencing	BOOL	FALSE			ALWAYS	ENGINEER	2	01779
0627	Comms Control Word	Parameters::Motor Control::Sequencing	WORD (bitfield)	0000	0:SWITCH ON 1:ENABLE VOLTAGE 2:NOT QUICKSTOP 3:ENABLE OPERATION 7:RESET FAULT 10:USE COMMS CONTROL 11:USE COMMS REFERENCE 12:USE JOG REFERENCE 13:REVERSE DIRECTION 14:AUTO INITIALISE 15:EVENT TRIGGERED OP		ALWAYS	TECHNICIAN	2	01781
0628	Comms Control Word.SWITCH ON	Parameters::Motor Control::Sequencing	BOOL	FALSE			ALWAYS	TECHNICIAN	2	01783
0629	Comms Control Word.ENABLE VOLTAGE	Parameters::Motor Control::Sequencing	BOOL	FALSE			ALWAYS	TECHNICIAN	2	01785
0630	Comms Control Word.NOT QUICKSTOP	Parameters::Motor Control::Sequencing	BOOL	FALSE			ALWAYS	TECHNICIAN	2	01787
0631	Comms Control Word.ENABLE OPERATION	Parameters::Motor Control::Sequencing	BOOL	FALSE			ALWAYS	TECHNICIAN	2	01789
0635	Comms Control Word.RESET FAULT	Parameters::Motor Control::Sequencing	BOOL	FALSE			ALWAYS	TECHNICIAN	2	01797
0638	Comms Control Word.USE COMMS CONTROL	Parameters::Motor Control::Sequencing	BOOL	FALSE			ALWAYS	TECHNICIAN	2	01803
0639	Comms Control Word.USE COMMS REFERENCE	Parameters::Motor Control::Sequencing	BOOL	FALSE			ALWAYS	TECHNICIAN	2	01805
0640	Comms Control Word.USE JOG REFERENCE	Parameters::Motor Control::Sequencing	BOOL	FALSE			ALWAYS	TECHNICIAN	2	01807
0641	Comms Control Word.REVERSE DIRECTION	Parameters::Motor Control::Sequencing	BOOL	FALSE			ALWAYS	TECHNICIAN	2	01809

Parameter Reference D-113

PNO	Name	Path(s)	Type	Default	Range	Units	WQ	View	Notes	MBus
0642	Comms Control Word.AUTO INITIALISE	Parameters::Motor Control::Sequencing	BOOL	FALSE			ALWAYS	TECHNICIAN	2	01811
0643	Comms Control Word.EVENT TRIGGERED OP	Parameters::Motor Control::Sequencing	BOOL	FALSE			ALWAYS	TECHNICIAN	2	01813
0644	Control Word	Parameters::Motor Control::Sequencing	WORD (bitfield)		0:SWITCH ON 1:ENABLE VOLTAGE 2:NOT QUICKSTOP 3:ENABLE OPERATION 7:RESET FAULT 10:USE COMMS CONTROL 11:USE COMMS REFERENCE 12:USE JOG REFERENCE 13:REVERSE DIRECTION 14:AUTO INITIALISE 15:EVENT TRIGGERED OP		NEVER	TECHNICIAN		01815
0645	Control Word.SWITCH ON	Parameters::Motor Control::Sequencing	BOOL				NEVER	TECHNICIAN		01817
0646	Control Word.ENABLE VOLTAGE	Parameters::Motor Control::Sequencing	BOOL				NEVER	TECHNICIAN		01819
0647	Control Word.NOT QUICKSTOP	Parameters::Motor Control::Sequencing	BOOL				NEVER	TECHNICIAN		01821
0648	Control Word.ENABLE OPERATION	Parameters::Motor Control::Sequencing	BOOL				NEVER	TECHNICIAN		01823
0652	Control Word.RESET FAULT	Parameters::Motor Control::Sequencing	BOOL				NEVER	TECHNICIAN		01831
0655	Control Word.USE COMMS CONTROL	Parameters::Motor Control::Sequencing	BOOL				NEVER	TECHNICIAN		01837
0656	Control Word.USE COMMS REFERENCE	Parameters::Motor Control::Sequencing	BOOL				NEVER	TECHNICIAN		01839
0657	Control Word.USE JOG REFERENCE	Parameters::Motor Control::Sequencing	BOOL				NEVER	TECHNICIAN		01841
0658	Control Word.REVERSE DIRECTION	Parameters::Motor Control::Sequencing	BOOL				NEVER	TECHNICIAN		01843
0659	Control Word.AUTO INITIALISE	Parameters::Motor Control::Sequencing	BOOL				NEVER	TECHNICIAN		01845
0660	Control Word.EVENT TRIGGERED OP	Parameters::Motor Control::Sequencing	BOOL				NEVER	TECHNICIAN		01847
0661	Status Word	Parameters::Motor Control::Sequencing	WORD (bitfield)		0:READY TO SWITCH ON 1:SWITCHED ON 2:OPERATION ENABLED 3:FAULTED 4:VOLTAGE ENABLED 5:QUICKSTOP INACTIVE 6:SWITCH ON DISABLED 9:CONTROL FROM COMMS 12:JOG OPERATION 13:REVERSE OPERATION 14:REFERENCE FROM COMMS 15:STOPPING		NEVER	TECHNICIAN		01849
0662	Status Word.READY TO SWITCH ON	Parameters::Motor Control::Sequencing	BOOL				NEVER	TECHNICIAN		01851
0663	Status Word.SWITCHED ON	Parameters::Motor Control::Sequencing	BOOL				NEVER	TECHNICIAN		01853
0664	Status Word.OPERATION ENABLED	Parameters::Motor Control::Sequencing	BOOL				NEVER	TECHNICIAN		01855
0665	Status Word.FAULTED	Parameters::Motor Control::Sequencing	BOOL				NEVER	TECHNICIAN		01857
0666	Status Word.VOLTAGE ENABLED	Parameters::Motor Control::Sequencing	BOOL				NEVER	TECHNICIAN		01859
0667	Status Word.QUICKSTOP INACTIVE	Parameters::Motor Control::Sequencing	BOOL				NEVER	TECHNICIAN		01861
0668	Status Word.SWITCH ON DISABLED	Parameters::Motor Control::Sequencing	BOOL				NEVER	TECHNICIAN		01863
0671	Status Word.CONTROL FROM COMMS	Parameters::Motor Control::Sequencing	BOOL				NEVER	TECHNICIAN		01869
0674	Status Word.JOG OPERATION	Parameters::Motor Control::Sequencing	BOOL				NEVER	TECHNICIAN		01875
0675	Status Word.REVERSE OPERATION	Parameters::Motor Control::Sequencing	BOOL				NEVER	TECHNICIAN		01877
0676	Status Word.REFERENCE FROM COMMS	Parameters::Motor Control::Sequencing	BOOL				NEVER	TECHNICIAN		01879
0677	Status Word.STOPPING	Parameters::Motor Control::Sequencing	BOOL				NEVER	TECHNICIAN		01881
0678	Sequencing State	Parameters::Motor Control::Sequencing	USINT (enum)		0:NOT READY TO SWITCH ON 1:SWITCH ON DISABLED 2:READY TO SWITCH ON 3:SWITCHED ON 4:OPERATION ENABLED 5:QUICKSTOP ACTIVE 6:FAULT REACTION ACTIVE 7:FAULTED		NEVER	TECHNICIAN		01883

D-114 Parameter Reference

PNO	Name	Path(s)	Type	Default	Range	Units	WQ	View	Notes	Mbus
0679	Switch On Timeout	Parameters::Motor Control::Sequencing	TIME	0.000	0.000 to 100.000	s	ALWAYS	TECHNICIAN		01885
0680	App Reference	Parameters::Motor Control::Sequencing	REAL	0.00	-110.00 to 110.00	%	ALWAYS	TECHNICIAN		01887
0681	Comms Reference	Parameters::Motor Control::Sequencing	REAL	0.00	-110.00 to 110.00	%	ALWAYS	TECHNICIAN		01889
0682	Reference	Parameters::Motor Control::Sequencing	REAL	x.xx	-110.00 to 110.00	%	NEVER	OPERATOR		01891
0689	PMAC Flycatching Enable	Parameters::Motor Control::PMAC Flycatching	BOOL	FALSE			ALWAYS	TECHNICIAN	4	01905
0690	PMAC Fly Search Model	Parameters::Motor Control::PMAC Flycatching	USINT (enum)	0	Same as PNO 312		ALWAYS	TECHNICIAN	4	01907
0691	PMAC Fly Search Time	Parameters::Motor Control::PMAC Flycatching	TIME	0.200	0.100 to 60.000	s	ALWAYS	TECHNICIAN	4	01909
0692	PMAC Fly Load Level	Parameters::Motor Control::PMAC Flycatching	REAL	5.0	-50.0 to 50.0	%	ALWAYS	TECHNICIAN	4	01911
0693	PMAC Fly Active	Parameters::Motor Control::PMAC Flycatching	BOOL				NEVER	TECHNICIAN	4	01913
0694	PMAC Fly Setpoint	Parameters::Motor Control::PMAC Flycatching	REAL	x.	-1000 to 1000	Hz	NEVER	TECHNICIAN	4	01915
0696	First Trip	Advanced Monitor::Trips Parameters::Trips::Trips Status	USINT (enum)		0:NONE 1:OVER VOLTAGE 2:UNDER VOLTAGE 3:OVER CURRENT 4:STACK FAULT 5:STACK OVER CURRENT 6:CURRENT LIMIT 7:MOTOR STALL 8:INVERSE TIME 9:MOTOR I2T 10:LOW SPEED I 11:HEATSINK OVERTEMP 12:AMBIENT OVERTEMP 13:MOTOR OVERTEMP 14:EXTERNAL TRIP 15:BRAKE SHORT CCT 16:BRAKE RESISTOR 17:BRAKE SWITCH 18:LOCAL CONTROL 19:COMMS BREAK 20:LINE CONTACTOR 21:PHASE FAIL 22:VDC RIPPLE 23:BASE MODBUS BREAK 24:24V OVERLOAD 25:PMAC SPEED ERROR 26:OVERSPEED 27:STO ACTIVE 28:INTERNAL FAULT		NEVER	OPERATOR		01919

Parameter Reference D-115

PNO	Name	Path(s)	Type	Default	Range	Units	WQ	View	Notes	Mbus
0697	Enable 1 - 32	Parameters::Trips::Trips Status	DWORD (bitfield)	0000FF7F	5:CURRENT LIMIT 6:MOTOR STALL 7:INVERSE TIME 8:MOTOR I2T 9:LOW SPEED I 11:AMBIENT OVERTEMP 12:MOTOR OVERTEMP 13:EXTERNAL TRIP 14:BRAKE SHORT CCT 15:BRAKE RESISTOR 16:BRAKE SWITCH 17:LOCAL CONTROL 18:COMMS BREAK 19:LINE CONTACTOR 20:PHASE FAIL 21:VDC RIPPLE 22:BASE MODBUS BREAK 23:24V OVERLOAD 24:PMAC SPEED ERROR 25:OVERSPEED		ALWAYS	TECHNICIAN		01921
0703	Enable 1 - 32.CURRENT LIMIT	Parameters::Trips::Trips Status	BOOL	TRUE			ALWAYS	TECHNICIAN		01933
0704	Enable 1 - 32.MOTOR STALL	Parameters::Trips::Trips Status	BOOL	TRUE			ALWAYS	TECHNICIAN		01935
0705	Enable 1 - 32.INVERSE TIME	Parameters::Trips::Trips Status	BOOL	FALSE			ALWAYS	TECHNICIAN		01937
0706	Enable 1 - 32.MOTOR I2T	Parameters::Trips::Trips Status	BOOL	TRUE			ALWAYS	TECHNICIAN		01939
0707	Enable 1 - 32.LOW SPEED I	Parameters::Trips::Trips Status	BOOL	TRUE			ALWAYS	TECHNICIAN		01941
0709	Enable 1 - 32.AMBIENT OVERTEMP	Parameters::Trips::Trips Status	BOOL	TRUE			ALWAYS	TECHNICIAN		01945
0710	Enable 1 - 32.MOTOR OVERTEMP	Parameters::Trips::Trips Status	BOOL	TRUE			ALWAYS	TECHNICIAN		01947
0711	Enable 1 - 32.EXTERNAL TRIP	Parameters::Trips::Trips Status	BOOL	TRUE			ALWAYS	TECHNICIAN		01949
0712	Enable 1 - 32.BRAKE SHORT CCT	Parameters::Trips::Trips Status	BOOL	TRUE			ALWAYS	TECHNICIAN		01951
0713	Enable 1 - 32.BRAKE RESISTOR	Parameters::Trips::Trips Status	BOOL	TRUE			ALWAYS	TECHNICIAN		01953
0714	Enable 1 - 32.BRAKE SWITCH	Parameters::Trips::Trips Status	BOOL	TRUE			ALWAYS	TECHNICIAN		01955
0715	Enable 1 - 32.LOCAL CONTROL	Parameters::Trips::Trips Status	BOOL	TRUE			ALWAYS	TECHNICIAN		01957
0716	Enable 1 - 32.COMMS BREAK	Parameters::Trips::Trips Status	BOOL	TRUE			ALWAYS	TECHNICIAN		01959
0717	Enable 1 - 32.LINE CONTACTOR	Parameters::Trips::Trips Status	BOOL	TRUE			ALWAYS	TECHNICIAN		01961
0718	Enable 1 - 32.PHASE FAIL	Parameters::Trips::Trips Status	BOOL	TRUE			ALWAYS	TECHNICIAN		01963
0719	Enable 1 - 32.VDC RIPPLE	Parameters::Trips::Trips Status	BOOL	TRUE			ALWAYS	TECHNICIAN		01965
0720	Enable 1 - 32.BASE MODBUS BREAK	Parameters::Trips::Trips Status	BOOL	TRUE			ALWAYS	TECHNICIAN		01967
0721	Enable 1 - 32.24V OVERLOAD	Parameters::Trips::Trips Status	BOOL	TRUE			ALWAYS	TECHNICIAN		01969
0722	Enable 1 - 32.PMAC SPEED ERROR	Parameters::Trips::Trips Status	BOOL	TRUE			ALWAYS	TECHNICIAN		01971
0723	Enable 1 - 32.OVERSPEED	Parameters::Trips::Trips Status	BOOL	TRUE			ALWAYS	TECHNICIAN		01973

D-116 Parameter Reference

PNO	Name	Path(s)	Type	Default	Range	Units	WQ	View	Notes	Mbus
0763	Active 1 - 32	Advanced Monitor::Trips Parameters::Trips::Trips Status	DWORD (bitfield)		0:OVER VOLTAGE 1:UNDER VOLTAGE 2:OVER CURRENT 3:STACK FAULT 4:STACK OVER CURRENT 5:CURRENT LIMIT 6:MOTOR STALL 7:INVERSE TIME 8:MOTOR I2T 9:LOW SPEED I 10:HEATSINK OVERTEMP 11:AMBIENT OVERTEMP 12:MOTOR OVERTEMP 13:EXTERNAL TRIP 14:BRAKE SHORT CCT 15:BRAKE RESISTOR 16:BRAKE SWITCH 17:LOCAL CONTROL 18:COMMS BREAK 19:LINE CONTACTOR 20:PHASE FAIL 21:VDC RIPPLE 22:BASE MODBUS BREAK 23:24V OVERLOAD 24:PMAC SPEED ERROR 25:OVERSPEED 26:STO ACTIVE 27:INTERNAL FAULT		NEVER	OPERATOR		02053
0764	Active 1 - 32.OVER VOLTAGE	Same as PNO 763	BOOL				NEVER	OPERATOR		02055
0765	Active 1 - 32.UNDER VOLTAGE	Same as PNO 763	BOOL				NEVER	OPERATOR		02057
0766	Active 1 - 32.OVER CURRENT	Same as PNO 763	BOOL				NEVER	OPERATOR		02059
0767	Active 1 - 32.STACK FAULT	Same as PNO 763	BOOL				NEVER	OPERATOR		02061
0768	Active 1 - 32.STACK OVER CURRENT	Same as PNO 763	BOOL				NEVER	OPERATOR		02063
0769	Active 1 - 32.CURRENT LIMIT	Same as PNO 763	BOOL				NEVER	OPERATOR		02065
0770	Active 1 - 32.MOTOR STALL	Same as PNO 763	BOOL				NEVER	OPERATOR		02067
0771	Active 1 - 32.INVERSE TIME	Same as PNO 763	BOOL				NEVER	OPERATOR		02069
0772	Active 1 - 32.MOTOR I2T	Same as PNO 763	BOOL				NEVER	OPERATOR		02071
0773	Active 1 - 32.LOW SPEED I	Same as PNO 763	BOOL				NEVER	OPERATOR		02073
0774	Active 1 - 32.HEATSINK OVERTEMP	Same as PNO 763	BOOL				NEVER	OPERATOR		02075
0775	Active 1 - 32.AMBIENT OVERTEMP	Same as PNO 763	BOOL				NEVER	OPERATOR		02077
0776	Active 1 - 32.MOTOR OVERTEMP	Same as PNO 763	BOOL				NEVER	OPERATOR		02079
0777	Active 1 - 32.EXTERNAL TRIP	Same as PNO 763	BOOL				NEVER	OPERATOR		02081
0778	Active 1 - 32.BRAKE SHORT CCT	Same as PNO 763	BOOL				NEVER	OPERATOR		02083
0779	Active 1 - 32.BRAKE RESISTOR	Same as PNO 763	BOOL				NEVER	OPERATOR		02085
0780	Active 1 - 32.BRAKE SWITCH	Same as PNO 763	BOOL				NEVER	OPERATOR		02087
0781	Active 1 - 32.LOCAL CONTROL	Same as PNO 763	BOOL				NEVER	OPERATOR		02089
0782	Active 1 - 32.COMMS BREAK	Same as PNO 763	BOOL				NEVER	OPERATOR		02091
0783	Active 1 - 32.LINE CONTACTOR	Same as PNO 763	BOOL				NEVER	OPERATOR		02093
0784	Active 1 - 32.PHASE FAIL	Same as PNO 763	BOOL				NEVER	OPERATOR		02095
0785	Active 1 - 32.VDC RIPPLE	Same as PNO 763	BOOL				NEVER	OPERATOR		02097
0786	Active 1 - 32.BASE MODBUS BREAK	Same as PNO 763	BOOL				NEVER	OPERATOR		02099
0787	Active 1 - 32.24V OVERLOAD	Same as PNO 763	BOOL				NEVER	OPERATOR		02101
0788	Active 1 - 32.PMAC SPEED ERROR	Same as PNO 763	BOOL				NEVER	OPERATOR		02103
0789	Active 1 - 32.OVERSPEED	Same as PNO 763	BOOL				NEVER	OPERATOR		02105
0790	Active 1 - 32.STO ACTIVE	Same as PNO 763	BOOL				NEVER	OPERATOR		02107
0791	Active 1 - 32.INTERNAL FAULT	Same as PNO 763	BOOL				NEVER	OPERATOR		02109

Parameter Reference D-117

PNO	Name	Path(s)	Type	Default	Range	Units	WQ	View	Notes	MBus
0829	Warnings 1 - 32	Advanced Monitor::Trips Parameters::Trips::Trips Status	DWORD (bitfield)		0:OVER VOLTAGE 1:UNDER VOLTAGE 2:OVER CURRENT 3:STACK FAULT 4:STACK OVER CURRENT 5:CURRENT LIMIT 6:MOTOR STALL 7:INVERSE TIME 8:MOTOR I2T 9:LOW SPEED I 10:HEATSINK OVERTEMP 11:AMBIENT OVERTEMP 12:MOTOR OVERTEMP 13:EXTERNAL TRIP 14:BRAKE SHORT CCT 15:BRAKE RESISTOR 16:BRAKE SWITCH 17:LOCAL CONTROL 18:COMMS BREAK 19:LINE CONTACTOR 20:PHASE FAIL 21:VDC RIPPLE 22:BASE MODBUS BREAK 23:24V OVERLOAD 24:PMAC SPEED ERROR 25:OVERSPEED 26:STO ACTIVE 27:INTERNAL FAULT		NEVER	OPERATOR		02185
0830	Warnings 1 - 32.OVER VOLTAGE	Same as PNO 829	BOOL				NEVER	OPERATOR		02187
0831	Warnings 1 - 32.UNDER VOLTAGE	Same as PNO 829	BOOL				NEVER	OPERATOR		02189
0832	Warnings 1 - 32.OVER CURRENT	Same as PNO 829	BOOL				NEVER	OPERATOR		02191
0833	Warnings 1 - 32.STACK FAULT	Same as PNO 829	BOOL				NEVER	OPERATOR		02193
0834	Warnings 1 - 32.STACK OVER CURRENT	Same as PNO 829	BOOL				NEVER	OPERATOR		02195
0835	Warnings 1 - 32.CURRENT LIMIT	Same as PNO 829	BOOL				NEVER	OPERATOR		02197
0836	Warnings 1 - 32.MOTOR STALL	Same as PNO 829	BOOL				NEVER	OPERATOR		02199
0837	Warnings 1 - 32.INVERSE TIME	Same as PNO 829	BOOL				NEVER	OPERATOR		02201
0838	Warnings 1 - 32.MOTOR I2T	Same as PNO 829	BOOL				NEVER	OPERATOR		02203
0839	Warnings 1 - 32.LOW SPEED I	Same as PNO 829	BOOL				NEVER	OPERATOR		02205
0840	Warnings 1 - 32.HEATSINK OVERTEMP	Same as PNO 829	BOOL				NEVER	OPERATOR		02207
0841	Warnings 1 - 32.AMBIENT OVERTEMP	Same as PNO 829	BOOL				NEVER	OPERATOR		02209
0842	Warnings 1 - 32.MOTOR OVERTEMP	Same as PNO 829	BOOL				NEVER	OPERATOR		02211
0843	Warnings 1 - 32.EXTERNAL TRIP	Same as PNO 829	BOOL				NEVER	OPERATOR		02213
0844	Warnings 1 - 32.BRAKE SHORT CCT	Same as PNO 829	BOOL				NEVER	OPERATOR		02215
0845	Warnings 1 - 32.BRAKE RESISTOR	Same as PNO 829	BOOL				NEVER	OPERATOR		02217
0846	Warnings 1 - 32.BRAKE SWITCH	Same as PNO 829	BOOL				NEVER	OPERATOR		02219
0847	Warnings 1 - 32.LOCAL CONTROL	Same as PNO 829	BOOL				NEVER	OPERATOR		02221
0848	Warnings 1 - 32.COMMS BREAK	Same as PNO 829	BOOL				NEVER	OPERATOR		02223
0849	Warnings 1 - 32.LINE CONTACTOR	Same as PNO 829	BOOL				NEVER	OPERATOR		02225
0850	Warnings 1 - 32.PHASE FAIL	Same as PNO 829	BOOL				NEVER	OPERATOR		02227
0851	Warnings 1 - 32.VDC RIPPLE	Same as PNO 829	BOOL				NEVER	OPERATOR		02229
0852	Warnings 1 - 32.BASE MODBUS BREAK	Same as PNO 829	BOOL				NEVER	OPERATOR		02231
0853	Warnings 1 - 32.24V OVERLOAD	Same as PNO 829	BOOL				NEVER	OPERATOR		02233
0854	Warnings 1 - 32.PMAC SPEED ERROR	Same as PNO 829	BOOL				NEVER	OPERATOR		02235
0855	Warnings 1 - 32.OVERSPEED	Same as PNO 829	BOOL				NEVER	OPERATOR		02237
0856	Warnings 1 - 32.STO ACTIVE	Same as PNO 829	BOOL				NEVER	OPERATOR		02239
0857	Warnings 1 - 32.INTERNAL FAULT	Same as PNO 829	BOOL				NEVER	OPERATOR		02241
0895	Recent Trips	Parameters::Trips::Trips History	ARRAY[0..9]				NEVER	OPERATOR		02317

D-118 Parameter Reference

PNO	Name	Path(s)	Type	Default	Range	Units	WQ	View	Notes	Mbus
0896	Recent Trips[0]	Parameters::Trips::Trips History	USINT (enum)		Same as PNO 696		NEVER	OPERATOR	1	02319
0897	Recent Trips[1]	Parameters::Trips::Trips History	USINT (enum)		Same as PNO 696		NEVER	OPERATOR	1	02321
0898	Recent Trips[2]	Parameters::Trips::Trips History	USINT (enum)		Same as PNO 696		NEVER	OPERATOR	1	02323
0899	Recent Trips[3]	Parameters::Trips::Trips History	USINT (enum)		Same as PNO 696		NEVER	OPERATOR	1	02325
0900	Recent Trips[4]	Parameters::Trips::Trips History	USINT (enum)		Same as PNO 696		NEVER	OPERATOR	1	02327
0901	Recent Trips[5]	Parameters::Trips::Trips History	USINT (enum)		Same as PNO 696		NEVER	OPERATOR	1	02329
0902	Recent Trips[6]	Parameters::Trips::Trips History	USINT (enum)		Same as PNO 696		NEVER	OPERATOR	1	02331
0903	Recent Trips[7]	Parameters::Trips::Trips History	USINT (enum)		Same as PNO 696		NEVER	OPERATOR	1	02333
0904	Recent Trips[8]	Parameters::Trips::Trips History	USINT (enum)		Same as PNO 696		NEVER	OPERATOR	1	02335
0905	Recent Trips[9]	Parameters::Trips::Trips History	USINT (enum)		Same as PNO 696		NEVER	OPERATOR	1	02337
0906	Stall Limit Type	Parameters::Trips::Stall Trip	USINT (enum)	2	0:TORQUE 1:CURRENT 2:TORQUE OR CURRENT		ALWAYS	TECHNICIAN		02339
0907	Stall Time	Parameters::Trips::Stall Trip	TIME	120.000	0.100 to 2000.000	s	ALWAYS	TECHNICIAN		02341
0909	Stall Torque Active	Parameters::Trips::Stall Trip	BOOL				NEVER	TECHNICIAN		02345
0910	Stall Current Active	Parameters::Trips::Stall Trip	BOOL				NEVER	TECHNICIAN		02347
0911	Stall Speed Feedback	Parameters::Trips::Stall Trip	REAL	x.	-200 to 200	%	NEVER	ENGINEER		02349
0912	VDC Ripple Filter TC	Parameters::Trips::VDC Ripple	TIME	1.000	0.100 to 100.000	s	ALWAYS	ENGINEER		02351
0913	Max VDC Ripple	Parameters::Trips::VDC Ripple	REAL	x.	0 to 500	V	NEVER	ENGINEER		02353
0914	VDC Ripple Trip Delay	Parameters::Trips::VDC Ripple	TIME		0.000 to 300.000	s	NEVER	ENGINEER		02355
0915	VDC Ripple Trip Hyst	Parameters::Trips::VDC Ripple	REAL	10	0 to 50	V	ALWAYS	ENGINEER		02357
0916	VDC Ripple Sample	Parameters::Trips::VDC Ripple	TIME	0.009	0.001 to 0.100	s	ALWAYS	ENGINEER		02359
0917	VDC Ripple Level	Parameters::Trips::VDC Ripple	REAL	x.	0 to 500	V	NEVER	ENGINEER		02361
0918	Filtered VDC Ripple	Parameters::Trips::VDC Ripple	REAL	x.	0 to 500	V	NEVER	ENGINEER		02363
0919	Ethernet State	Advanced Monitor::Communications::Base Ethernet Parameters::Base Comms::Ethernet	USINT (enum)		0:INITIALISING 1:NO LINK 2:RESOLVING IP 3:RESOLVING DHCP 4:RESOLVING AUTO 5:RESOLVED IP 6:STOPPING DHCP 7:DUPLICATE IP 8:FAULT		NEVER	OPERATOR		02365
0920	MAC Address	Same as PNO 919	STRING				NEVER	OPERATOR		02367
0926	IP Address	Same as PNO 919	DWORD (IP addr)				NEVER	OPERATOR		02379
0927	Subnet Mask	Same as PNO 919	DWORD (IP addr)				NEVER	OPERATOR		02381
0928	Gateway Address	Same as PNO 919	DWORD (IP addr)				NEVER	OPERATOR		02383
0929	DHCP	Advanced Setup::Communications::Base Ethernet Parameters::Base Comms::Ethernet	BOOL	TRUE			ALWAYS	TECHNICIAN		02385
0930	Auto IP	Same as PNO 929	BOOL	TRUE			ALWAYS	TECHNICIAN		02387
0931	Last Auto IP Address	Parameters::Base Comms::Ethernet	DWORD (IP addr)				NEVER	ENGINEER	1	02389
0932	DHCP To Auto IP	Same as PNO 929	TIME	45.000	30.000 to 300.000	s	ALWAYS	TECHNICIAN	4	02391
0933	User IP Address	Same as PNO 929	DWORD (IP addr)	000.000.000.000			ALWAYS	TECHNICIAN	4	02393
0934	User Subnet Mask	Same as PNO 929	DWORD (IP addr)	000.000.000.000			ALWAYS	TECHNICIAN	4	02395
0935	User Gateway Address	Same as PNO 929	DWORD (IP addr)	000.000.000.000			ALWAYS	TECHNICIAN	4	02397
0937	Ethernet Diagnostic	Parameters::Base Comms::Ethernet	DWORD				NEVER	ENGINEER		02401
0938	Free Packets	Parameters::Base Comms::Ethernet	UDINT		0 to 100		NEVER	ENGINEER		02403
0939	Maximum Connections	Advanced Setup::Communications::Base Modbus Parameters::Base Comms::Modbus	USINT	0	0 to 3		ALWAYS	TECHNICIAN		02405

Parameter Reference D-119

PNO	Name	Path(s)	Type	Default	Range	Units	WQ	View	Notes	Mbus
0940	High Word First	Same as PNO 939	BOOL	FALSE			ALWAYS	TECHNICIAN		02407
0941	Modbus Timeout	Same as PNO 939	TIME	3.000	0.000 to 65.000	s	ALWAYS	TECHNICIAN		02409
0942	Modbus Trip Enable	Same as PNO 939	BOOL	TRUE			ALWAYS	TECHNICIAN		02411
0943	Process Active	Advanced Monitor::Communications::Base Modbus Parameters::Base Comms::Modbus	BOOL				NEVER	OPERATOR		02413
0944	Web Access	Advanced Setup::Communications::Base Ethernet Advanced Setup::Environment Parameters::Base Comms::Web Server	USINT (enum)	1	0:DISABLED 1:LIMITED 2:FULL		ALWAYS	TECHNICIAN		02415
0945	Web View Level	Parameters::Base Comms::Web Server	USINT (enum)	1	0:OPERATOR 1:TECHNICIAN 2:ENGINEER		ALWAYS	OPERATOR		02417
0946	Web Password	Parameters::Base Comms::Web Server	STRING				ALWAYS	ENGINEER		02419
0961	Drive Name	Advanced Setup::Environment Parameters::Device Manager::Drive info	STRING				ALWAYS	TECHNICIAN		02449
0977	Control Module Serial	Parameters::Device Manager::Drive info	STRING				CONFIG	OPERATOR	2	02481
0982	Startup Page	Parameters::Keypad::Graphical Keypad	USINT (enum)	0	0:DEFAULT 1:LOCAL 2:FAVOURITES 3:MONITOR		ALWAYS	TECHNICIAN		02491
0983	Display Timeout	Parameters::Keypad::Graphical Keypad	TIME	0.000	0.000 to 86400.000	s	ALWAYS	TECHNICIAN		02493
0988	Target State	Parameters::Device Manager::Device State	USINT (enum)	3	3:PREOPERATIONAL 7:OPERATIONAL		ALWAYS	OPERATOR	2	02503
0989	Actual State	Parameters::Device Manager::Device State	USINT (enum)		0:INITIALISING 1:INITIALISED 2:PREPARING PREOP 3:PREOPERATIONAL 4:PREPARING OP 5:FAILED TO READY 6:READY FOR OP 7:OPERATIONAL 8:FAULTED 9:FATAL ERROR RECOVER		NEVER	OPERATOR		02505
0990	Application FE State	Parameters::Device Manager::Device State	USINT (enum)		Same as PNO 989		NEVER	OPERATOR		02507
0991	Base IO FE State	Parameters::Device Manager::Device State	USINT (enum)		Same as PNO 989		NEVER	OPERATOR		02509
0992	Basic Drive FE State	Parameters::Device Manager::Device State	USINT (enum)		Same as PNO 989		NEVER	OPERATOR		02511
0993	Ethernet FE State	Parameters::Device Manager::Device State	USINT (enum)		Same as PNO 989		NEVER	OPERATOR		02513
0994	Keypad FE State	Parameters::Device Manager::Device State	USINT (enum)		Same as PNO 989		NEVER	OPERATOR		02515
0995	Comms Option FE State	Parameters::Device Manager::Device State	USINT (enum)		Same as PNO 989		NEVER	OPERATOR		02517
0996	IO Option FE State	Parameters::Device Manager::Device State	USINT (enum)		Same as PNO 989		NEVER	OPERATOR		02519
0997	Config Fault Area	Parameters::Device Manager::Device State	USINT (enum)		0:NONE 1:POWER STACK 2:OPTION IO 3:OPTION COMMS 4:APPLICATION 5:MOTOR CONTROL 6:KEYPAD 7:BASE COMMS 8:BASE IO		NEVER	OPERATOR		02521
0998	RTA Code	Advanced Monitor::Trips Parameters::Device Manager::Device State	UINT		0 to 65535		NEVER	OPERATOR	4	02523
0999	RTA Data	Same as PNO 998	DWORD				NEVER	OPERATOR	4	02525
1001	Save All Parameters	Parameters::Device Manager::Device Commands	BOOL	FALSE			ALWAYS	OPERATOR	2	02529
1002	Update Firmware	Update Firmware Parameters::Device Manager::Device Commands	BOOL	FALSE			STOPPED	OPERATOR	2,4	02531
1004	Thermistor Trip Level	Parameters::Option IO::General Purpose IO	REAL	1000	0 to 4500	Ohms	ALWAYS	TECHNICIAN	4	02535

D-120 Parameter Reference

PNO	Name	Path(s)	Type	Default	Range	Units	WQ	View	Notes	MBus
1005	Language	Advanced Setup::Environment Parameters::Device Manager::Setup Wizard	USINT (enum)	0	0:ENGLISH 1:FRANCAIS 2:DEUTSCH 3:ESPAÑOL 4:ITALIANO		ALWAYS	TECHNICIAN		02537
1006	Run Setup?	Parameters::Device Manager::Setup Wizard	USINT (enum)	1	0:NO 1:YES		CONFIG	TECHNICIAN		02539
1033	Card State	Parameters::Device Manager::SD Card	USINT (enum)		0:NO CARD 1:INITIALISING 2:READY 3:CARD FAULT		NEVER	OPERATOR	3	02593
1034	Card Name	Parameters::Device Manager::SD Card	STRING				NEVER	OPERATOR	3	02595
1038	Firmware	Parameters::Device Manager::SD Card	BOOL				NEVER	OPERATOR	3	02603
1039	Application	Parameters::Device Manager::SD Card	BOOL				NEVER	OPERATOR	3	02605
1040	Project Name	Parameters::Application::App Info	STRING				NEVER	TECHNICIAN		02607
1047	Last Modification	Parameters::Application::App Info	DT		1970/01/01 to 2106/02/07		NEVER	TECHNICIAN		02621
1048	IDE Version	Parameters::Application::App Info	STRING				NEVER	TECHNICIAN		02623
1054	Project Author	Parameters::Application::App Info	STRING				NEVER	TECHNICIAN		02635
1061	Project Version	Parameters::Application::App Info	STRING				NEVER	TECHNICIAN		02649
1068	Project Description	Parameters::Application::App Info	STRING				NEVER	TECHNICIAN		02663
1097	Password in Favourite	Parameters::Keypad::Graphical Keypad	BOOL	FALSE			ALWAYS	TECHNICIAN		02721
1098	Password in Local	Parameters::Keypad::Graphical Keypad	BOOL	FALSE			ALWAYS	TECHNICIAN		02723
1100	Firmware Version	Parameters::Device Manager::Drive info	STRING				NEVER	OPERATOR		02727
1109	Stack Pcode	Parameters::Device Manager::Drive info	STRING				CONFIG	OPERATOR	2	02745
1116	Control Module Pcode	Parameters::Device Manager::Drive info	STRING				CONFIG	OPERATOR	2	02759
1121	Comms Option Pcode	Parameters::Device Manager::Drive info	STRING				CONFIG	OPERATOR	2,4	02769
1125	IO Option Pcode	Parameters::Device Manager::Drive info	STRING				CONFIG	OPERATOR	2,4	02777
1129	Comms Option Serial	Parameters::Device Manager::Drive info	STRING				ALWAYS	OPERATOR	4	02785
1134	IO Option Serial No	Parameters::Device Manager::Drive info	STRING				CONFIG	OPERATOR	2,4	02795
1140	Run Key Action	Control Screen Parameters::Keypad::Local Control	USINT (enum)	0	0:RUN 1:JOG		STOPPED	OPERATOR	4	02807
1141	View Level	Advanced Setup::Environment Parameters::Keypad::Graphical Keypad	USINT (enum)	1	Same as PNO 945		ALWAYS	OPERATOR		02809
1142	GKP Password	Same as PNO 1141	WORD	0000			ALWAYS	TECHNICIAN		02811
1143	Version	Parameters::Keypad::Graphical Keypad	WORD				NEVER	OPERATOR		02813
1178	IO Option Type	Advanced Setup::Inputs and Outputs Parameters::Option IO::IO Option Common	USINT (enum)	0	0:NONE 1:GENERAL PURPOSE 2:THERMISTOR 3:RTC AND THERMISTOR		CONFIG	TECHNICIAN		02883
1179	Actual IO Option	Parameters::Option IO::IO Option Common	USINT (enum)		Same as PNO 1178		NEVER	OPERATOR		02885
1180	IO Option Status	Parameters::Option IO::IO Option Common	USINT (enum)		0:OK 1:OPTION NOT FITTED 2:TYPE MISMATCH 3:TYPE UNKNOWN 4:HARDWARE FAULT		NEVER	OPERATOR		02887
1181	Anin 11 Value	Advanced Monitor::Inputs and Outputs Parameters::Option IO::General Purpose IO	REAL	x.xx	-100.00 to 100.00	%	NEVER	OPERATOR	4	02889
1182	Anin 12 Value	Same as PNO 1181	REAL	x.xx	-100.00 to 100.00	%	NEVER	OPERATOR	4	02891
1183	Anin 13 Value	Same as PNO 1181	REAL	x.xx	-100.00 to 100.00	%	NEVER	OPERATOR	4	02893
1184	Thermistor Type	Advanced Setup::Inputs and Outputs Parameters::Option IO::General Purpose IO	USINT (enum)	1	0:NTC 1:PTC 2:KTY		ALWAYS	OPERATOR	4	02895
1185	Thermistor Resistance	Parameters::Option IO::General Purpose IO	REAL	x.	0 to 4500	Ohms	NEVER	OPERATOR	4	02897
1186	Time and Date	Parameters::Device Manager::Real Time Clock	DT	1970/01/01	1970/01/01 to 2106/02/07		ALWAYS	OPERATOR	2	02899
1187	RTC Trim	Parameters::Option IO::General Purpose IO	SINT	0	-40 to 40		ALWAYS	ENGINEER	2,4	02901
1188	Favourites	Parameters::Device Manager::Soft Menus	ARRAY[0..19]				ALWAYS	OPERATOR		02903

Parameter Reference D-121

PNO	Name	Path(s)	Type	Default	Range	Units	WQ	View	Notes	Mbus
1189	Favourites[0]	Parameters::Device Manager::Soft Menu	UINT	0000	0000 to 2039		ALWAYS	OPERATOR		02905
1190	Favourites[1]	Parameters::Device Manager::Soft Menu	UINT	0000	0000 to 2039		ALWAYS	OPERATOR		02907
1191	Favourites[2]	Parameters::Device Manager::Soft Menu	UINT	0000	0000 to 2039		ALWAYS	OPERATOR		02909
1192	Favourites[3]	Parameters::Device Manager::Soft Menu	UINT	0000	0000 to 2039		ALWAYS	OPERATOR		02911
1193	Favourites[4]	Parameters::Device Manager::Soft Menu	UINT	0000	0000 to 2039		ALWAYS	OPERATOR		02913
1194	Favourites[5]	Parameters::Device Manager::Soft Menu	UINT	0000	0000 to 2039		ALWAYS	OPERATOR		02915
1195	Favourites[6]	Parameters::Device Manager::Soft Menu	UINT	0000	0000 to 2039		ALWAYS	OPERATOR		02917
1196	Favourites[7]	Parameters::Device Manager::Soft Menu	UINT	0000	0000 to 2039		ALWAYS	OPERATOR		02919
1197	Favourites[8]	Parameters::Device Manager::Soft Menu	UINT	0000	0000 to 2039		ALWAYS	OPERATOR		02921
1198	Favourites[9]	Parameters::Device Manager::Soft Menu	UINT	0000	0000 to 2039		ALWAYS	OPERATOR		02923
1199	Favourites[10]	Parameters::Device Manager::Soft Menu	UINT	0000	0000 to 2039		ALWAYS	OPERATOR		02925
1200	Favourites[11]	Parameters::Device Manager::Soft Menu	UINT	0000	0000 to 2039		ALWAYS	OPERATOR		02927
1201	Favourites[12]	Parameters::Device Manager::Soft Menu	UINT	0000	0000 to 2039		ALWAYS	OPERATOR		02929
1202	Favourites[13]	Parameters::Device Manager::Soft Menu	UINT	0000	0000 to 2039		ALWAYS	OPERATOR		02931
1203	Favourites[14]	Parameters::Device Manager::Soft Menu	UINT	0000	0000 to 2039		ALWAYS	OPERATOR		02933
1204	Favourites[15]	Parameters::Device Manager::Soft Menu	UINT	0000	0000 to 2039		ALWAYS	OPERATOR		02935
1205	Favourites[16]	Parameters::Device Manager::Soft Menu	UINT	0000	0000 to 2039		ALWAYS	OPERATOR		02937
1206	Favourites[17]	Parameters::Device Manager::Soft Menu	UINT	0000	0000 to 2039		ALWAYS	OPERATOR		02939
1207	Favourites[18]	Parameters::Device Manager::Soft Menu	UINT	0000	0000 to 2039		ALWAYS	OPERATOR		02941
1208	Favourites[19]	Parameters::Device Manager::Soft Menu	UINT	0000	0000 to 2039		ALWAYS	OPERATOR		02943
1239	Local Run Key Active	Parameters::Keypad::Local Control	BOOL	TRUE			ALWAYS	TECHNICIAN		03005
1240	Local Reverse	Control Screen Parameters::Keypad::Local Control	BOOL	FALSE			ALWAYS	OPERATOR	1,4	03007
1241	Open Connections	Advanced Monitor::Communications::Base Modbus Parameters::Base Comms::Modbus	USINT		0 to 255		NEVER	OPERATOR		03009
1246	Speed Loop Auto Set	Parameters::Motor Control::Spd Loop Settings	BOOL	TRUE			ALWAYS	TECHNICIAN	4	03019
1247	Ratio Load Mot Inert	Parameters::Motor Control::Spd Loop Settings	REAL	1.0	0.1 to 100.0		ALWAYS	TECHNICIAN	4	03021
1248	Speed Loop Bandwidth	Parameters::Motor Control::Spd Loop Settings	USINT (enum)	1	0:LOW 1:MEDIUM 2:HIG		ALWAYS	TECHNICIAN	4	03023
1251	CANopen Actual Baud	Advanced Monitor::Communications::Option Parameters::Option Comms::CANopen	USINT (enum)		Same as PNO 213		NEVER	OPERATOR	4	03029
1253	Local/Rem Key Active	Parameters::Keypad::Local Control	BOOL	TRUE			ALWAYS	TECHNICIAN		03033
1254	IO Option SW Version	Parameters::Device Manager::Drive info	WORD				NEVER	OPERATOR	4	03035
1255	Local Dir Key Active	Parameters::Keypad::Local Control	BOOL	TRUE			ALWAYS	TECHNICIAN		03037
1257	Seq Stop Method SVC	Advanced Setup::Motor Control::Control and Type Parameters::Motor Control::Ramp	USINT (enum)	1	0:DISABLED VOLTAGE 1:RAMP 2:STOP RAMP		ALWAYS	TECHNICIAN	4	03041
1258	Stack Serial No	Parameters::Device Manager::Drive info	STRING				CONFIG	OPERATOR	2	03043
1264	Ref Min Speed Clamp	Parameters::Motor Control::Speed Ref	REAL	-110.00	-110.00 to 0.00	%	ALWAYS	OPERATOR		03055
1265	Ref Max Speed Clamp	Parameters::Motor Control::Speed Ref	REAL	110.00	0.00 to 110.00	%	ALWAYS	OPERATOR		03057
1266	Ref Speed Trim	Parameters::Motor Control::Speed Ref	REAL	0.00	-300.00 to 300.00	%	ALWAYS	OPERATOR		03059
1267	Ref Trim Local	Parameters::Motor Control::Speed Ref	BOOL	FALSE			ALWAYS	OPERATOR		03061
1268	Random Pattern PMAC	Parameters::Motor Control::Pattern Generator	BOOL	FALSE			ALWAYS	ENGINEER	4	03063
1269	DHCP State	Parameters::Base Comms::Ethernet	DWORD				NEVER	ENGINEER		03065
1270	Monitor	Parameters::Device Manager::Soft Menu	ARRAY[0..19]				ALWAYS	OPERATOR		03067
1271	Monitor[0]	Parameters::Device Manager::Soft Menu	UINT	0383	0000 to 2039		ALWAYS	OPERATOR	2	03069
1272	Monitor[1]	Parameters::Device Manager::Soft Menu	UINT	0393	0000 to 2039		ALWAYS	OPERATOR	2	03071
1273	Monitor[2]	Parameters::Device Manager::Soft Menu	UINT	0395	0000 to 2039		ALWAYS	OPERATOR	2	03073
1274	Monitor[3]	Parameters::Device Manager::Soft Menu	UINT	0696	0000 to 2039		ALWAYS	OPERATOR	2	03075
1275	Monitor[4]	Parameters::Device Manager::Soft Menu	UINT	0895	0000 to 2039		ALWAYS	OPERATOR	2	03077
1276	Monitor[5]	Parameters::Device Manager::Soft Menu	UINT	0926	0000 to 2039		ALWAYS	OPERATOR	2	03079
1277	Monitor[6]	Parameters::Device Manager::Soft Menu	UINT	0000	0000 to 2039		ALWAYS	OPERATOR	2	03081
1278	Monitor[7]	Parameters::Device Manager::Soft Menu	UINT	0000	0000 to 2039		ALWAYS	OPERATOR	2	03083
1279	Monitor[8]	Parameters::Device Manager::Soft Menu	UINT	0000	0000 to 2039		ALWAYS	OPERATOR	2	03085
1280	Monitor[9]	Parameters::Device Manager::Soft Menu	UINT	0000	0000 to 2039		ALWAYS	OPERATOR	2	03087

D-122 Parameter Reference

PNO	Name	Path(s)	Type	Default	Range	Units	WQ	View	Notes	MBus
1281	Monitor[10]	Parameters::Device Manager::Soft Menus	UINT	0000	0000 to 2039		ALWAYS	OPERATOR	2	03089
1282	Monitor[11]	Parameters::Device Manager::Soft Menus	UINT	0000	0000 to 2039		ALWAYS	OPERATOR	2	03091
1283	Monitor[12]	Parameters::Device Manager::Soft Menus	UINT	0000	0000 to 2039		ALWAYS	OPERATOR	2	03093
1284	Monitor[13]	Parameters::Device Manager::Soft Menus	UINT	0000	0000 to 2039		ALWAYS	OPERATOR	2	03095
1285	Monitor[14]	Parameters::Device Manager::Soft Menus	UINT	0000	0000 to 2039		ALWAYS	OPERATOR	2	03097
1286	Monitor[15]	Parameters::Device Manager::Soft Menus	UINT	0000	0000 to 2039		ALWAYS	OPERATOR	2	03099
1287	Monitor[16]	Parameters::Device Manager::Soft Menus	UINT	0000	0000 to 2039		ALWAYS	OPERATOR	2	03101
1288	Monitor[17]	Parameters::Device Manager::Soft Menus	UINT	0000	0000 to 2039		ALWAYS	OPERATOR	2	03103
1289	Monitor[18]	Parameters::Device Manager::Soft Menus	UINT	0000	0000 to 2039		ALWAYS	OPERATOR	2	03105
1290	Monitor[19]	Parameters::Device Manager::Soft Menus	UINT	0000	0000 to 2039		ALWAYS	OPERATOR	2	03107
1311	Setup	Parameters::Device Manager::Soft Menus	ARRAY[0..19]				ALWAYS	OPERATOR		03149
1312	Setup[0]	Parameters::Device Manager::Soft Menus	UINT	1141	0000 to 2039		ALWAYS	OPERATOR	2	03151
1313	Setup[1]	Parameters::Device Manager::Soft Menus	UINT	1006	0000 to 2039		ALWAYS	OPERATOR	2	03153
1314	Setup[2]	Parameters::Device Manager::Soft Menus	UINT	0000	0000 to 2039		ALWAYS	OPERATOR	2	03155
1315	Setup[3]	Parameters::Device Manager::Soft Menus	UINT	0000	0000 to 2039		ALWAYS	OPERATOR	2	03157
1316	Setup[4]	Parameters::Device Manager::Soft Menus	UINT	0000	0000 to 2039		ALWAYS	OPERATOR	2	03159
1317	Setup[5]	Parameters::Device Manager::Soft Menus	UINT	0000	0000 to 2039		ALWAYS	OPERATOR	2	03161
1318	Setup[6]	Parameters::Device Manager::Soft Menus	UINT	0000	0000 to 2039		ALWAYS	OPERATOR	2	03163
1319	Setup[7]	Parameters::Device Manager::Soft Menus	UINT	0000	0000 to 2039		ALWAYS	OPERATOR	2	03165
1320	Setup[8]	Parameters::Device Manager::Soft Menus	UINT	0000	0000 to 2039		ALWAYS	OPERATOR	2	03167
1321	Setup[9]	Parameters::Device Manager::Soft Menus	UINT	0000	0000 to 2039		ALWAYS	OPERATOR	2	03169
1322	Setup[10]	Parameters::Device Manager::Soft Menus	UINT	0000	0000 to 2039		ALWAYS	OPERATOR	2	03171
1323	Setup[11]	Parameters::Device Manager::Soft Menus	UINT	0000	0000 to 2039		ALWAYS	OPERATOR	2	03173
1324	Setup[12]	Parameters::Device Manager::Soft Menus	UINT	0000	0000 to 2039		ALWAYS	OPERATOR	2	03175
1325	Setup[13]	Parameters::Device Manager::Soft Menus	UINT	0000	0000 to 2039		ALWAYS	OPERATOR	2	03177
1326	Setup[14]	Parameters::Device Manager::Soft Menus	UINT	0000	0000 to 2039		ALWAYS	OPERATOR	2	03179
1327	Setup[15]	Parameters::Device Manager::Soft Menus	UINT	0000	0000 to 2039		ALWAYS	OPERATOR	2	03181
1328	Setup[16]	Parameters::Device Manager::Soft Menus	UINT	0000	0000 to 2039		ALWAYS	OPERATOR	2	03183
1329	Setup[17]	Parameters::Device Manager::Soft Menus	UINT	0000	0000 to 2039		ALWAYS	OPERATOR	2	03185
1330	Setup[18]	Parameters::Device Manager::Soft Menus	UINT	0000	0000 to 2039		ALWAYS	OPERATOR	2	03187
1331	Setup[19]	Parameters::Device Manager::Soft Menus	UINT	0000	0000 to 2039		ALWAYS	OPERATOR	2	03189
1900	Selected Application		USINT (enum)	0	0:BASIC SPEED CONTROL 1:AUTO/MANUAL CONTROL 2:SPEED RAISE / LOWER 3:SPEED PRESETS 4:PROCESS PID 5:AUXILLARY COMMS		ALWAYS	TECHNICIAN		04341
1901	RL Ramp Time	Advanced Setup::Application::Raise Lower	TIME	10.0	0.0 to 600.0	s	ALWAYS	TECHNICIAN	5	04329
1902	RL Reset Value	Advanced Setup::Application::Raise Lower	REAL	0.0	-500.0 to 500.0	%	ALWAYS	TECHNICIAN	5	04331
1903	RL Maximum Value	Advanced Setup::Application::Raise Lower	REAL	100.0	-500.0 to 500.0	%	ALWAYS	TECHNICIAN	5	04333
1904	RL Minimum Value	Advanced Setup::Application::Raise Lower	REAL	-100.0	-500.0 to 500.0	%	ALWAYS	TECHNICIAN	5	04335
1905	Raise Lower Output	Advanced Monitor::Application::Raise Lower	REAL	0.0	-500.0 to 500.0		NEVER	TECHNICIAN	1,5	04337
1906	Minimum Speed Value	Advanced Setup::Application::Minimum Speed	REAL	-100.0	-100.0 to 100.0	%	ALWAYS	TECHNICIAN	5	04339
1907	Minimum Speed Mode	Advanced Setup::Application::Minimum Speed	USINT (enum)	0	0:PROP WITH MINIMUM 1:LINEAR		ALWAYS	TECHNICIAN	5	04341
1908	Skip Band 1	Advanced Setup::Application::Skip Frequencies	REAL	0.0	0.0 to 1000.0	Hz	ALWAYS	TECHNICIAN	5	04343
1909	Skip Frequency 1	Advanced Setup::Application::Skip Frequencies	REAL	0.0	0.0 to 1000.0	Hz	ALWAYS	TECHNICIAN	5	04345
1910	Skip Band 2	Advanced Setup::Application::Skip Frequencies	REAL	0.0	0.0 to 1000.0	Hz	ALWAYS	TECHNICIAN	5	04347
1911	Skip Frequency 2	Advanced Setup::Application::Skip Frequencies	REAL	0.0	0.0 to 1000.0	Hz	ALWAYS	TECHNICIAN	5	04349
1912	Skip Band 3	Advanced Setup::Application::Skip Frequencies	REAL	0.0	0.0 to 1000.0	Hz	ALWAYS	TECHNICIAN	5	04351
1913	Skip Frequency 3	Advanced Setup::Application::Skip Frequencies	REAL	0.0	0.0 to 1000.0	Hz	ALWAYS	TECHNICIAN	5	04353
1914	Skip Band 4	Advanced Setup::Application::Skip Frequencies	REAL	0.0	0.0 to 1000.0	Hz	ALWAYS	TECHNICIAN	5	04355
1915	Skip Frequency 4	Advanced Setup::Application::Skip Frequencies	REAL	0.0	0.0 to 1000.0	Hz	ALWAYS	TECHNICIAN	5	04357
1916	Preset Speed 0	Advanced Setup::Application::Preset Speeds	REAL	0.0	-100.0 to 100.0	%	ALWAYS	TECHNICIAN	5	04359
1917	Preset Speed 1	Advanced Setup::Application::Preset Speeds	REAL	0.0	-100.0 to 100.0	%	ALWAYS	TECHNICIAN	5	04361
1918	Preset Speed 2	Advanced Setup::Application::Preset Speeds	REAL	0.0	-100.0 to 100.0	%	ALWAYS	TECHNICIAN	5	04363

Parameter Reference D-123

PNO	Name	Path(s)	Type	Default	Range	Units	WQ	View	Notes	MBus
1919	Preset Speed 3	Advanced Setup::Application::Preset Speeds	REAL	0.0	-100.0 to 100.0	%	ALWAYS	TECHNICIAN	5	04365
1920	Preset Speed 4	Advanced Setup::Application::Preset Speeds	REAL	0.0	-100.0 to 100.0	%	ALWAYS	TECHNICIAN	5	04367
1921	Preset Speed 5	Advanced Setup::Application::Preset Speeds	REAL	0.0	-100.0 to 100.0	%	ALWAYS	TECHNICIAN	5	04369
1922	Preset Speed 6	Advanced Setup::Application::Preset Speeds	REAL	0.0	-100.0 to 100.0	%	ALWAYS	TECHNICIAN	5	04371
1923	Preset Speed 7	Advanced Setup::Application::Preset Speeds	REAL	0.0	-100.0 to 100.0	%	ALWAYS	TECHNICIAN	5	04373
1924	Selected Preset	Advanced Monitor::Application::Preset Speeds	USINT		0 to 7		NEVER	TECHNICIAN	5	04375
1925	Preset Speed Output	Advanced Monitor::Application::Preset Speeds	REAL		-100.0 to 100.0	%	NEVER	TECHNICIAN	5	04377
1926	PID Setpoint Negate	Advanced Setup::Application::PID	BOOL	TRUE			ALWAYS	TECHNICIAN	5	04379
1927	PID Feedback Negate	Advanced Setup::Application::PID	BOOL	TRUE			ALWAYS	TECHNICIAN	5	04381
1928	PID Proportional Gain	Advanced Setup::Application::PID	REAL	1.0			ALWAYS	TECHNICIAN	5	04383
1929	PID Integral TC	Advanced Setup::Application::PID	TIME	1.00	0.01 to 100.00	s	ALWAYS	TECHNICIAN	5	04385
1930	PID Derivative TC	Advanced Setup::Application::PID	TIME	0.000	0.000 to 10.000	s	ALWAYS	TECHNICIAN	5	04387
1931	PID Output Filter TC	Advanced Setup::Application::PID	TIME	0.100	0.000 to 10.000	s	ALWAYS	TECHNICIAN	5	04389
1932	PID Output Pos Limit	Advanced Setup::Application::PID	REAL	100.00	0.00 to 105.00	%	ALWAYS	TECHNICIAN	5	04391
1933	PID Output Neg Limit	Advanced Setup::Application::PID	REAL	-100.00	-105.00 to 0.00	%	ALWAYS	TECHNICIAN	5	04393
1934	PID Output Scaling	Advanced Setup::Application::PID	REAL	1.000	-10.000 to 10.000		ALWAYS	TECHNICIAN	5	04395
1935	PID Output	Advanced Monitor::Application::PID	REAL		-105.00 to 105.00	%	NEVER	TECHNICIAN	5	04397
1936	PID Error	Advanced Monitor::Application::PID	REAL		-105.00 to 105.00	%	NEVER	TECHNICIAN	5	04399

D-124 Parameter Reference

Table of Parameters in Alphabetical Order

This table is a list of all the parameters in the AC30V showing the parameter name, number and the section in this appendix in which the parameter is described.

PNO	Parameter Name	Block
0332	100% Mot Current	Motor Load
0464	100% Speed in RPM	Scale Setpoint
0403	100% Stack Current A	Feedbacks
0343	100% Stk Current	Stack Inv Time
0450	Acceleration Boost	Fluxing VHz
0486	Acceleration Time	Ramp
0763	Active 1 - 32	Trips Status
0400	Actual Field Current	Feedbacks
1179	Actual IO Option	IO Option Common
0339	Actual Mot I2T Output	Motor Load
0421	Actual Neg Torque Lim	Torque Limit
0420	Actual Pos Torque Lim	Torque Limit
0394	Actual Speed Hz	Feedbacks
0395	Actual Speed Percent	Feedbacks
0393	Actual Speed RPM	Feedbacks
0989	Actual State	Device State
0399	Actual Torque	Feedbacks
0199	Address Assignment	Option Ethernet
0040	Anin 01 Break	IO Values
0001	Anin 01 Type	IO Configure
0039	Anin 01 Value	IO Values
0002	Anin 02 Type	IO Configure
0041	Anin 02 Value	IO Values
1181	Anin 11 Value	General Purpose IO
1182	Anin 12 Value	General Purpose IO
1183	Anin 13 Value	General Purpose IO
0003	Anout 01 Type	IO Configure
0042	Anout 01 Value	IO Values
0004	Anout 02 Type	IO Configure
0043	Anout 02 Value	IO Values
0610	App Control Word	Sequencing
0680	App Reference	Sequencing
0990	Application FE State	Device State
0448	Auto Boost	Fluxing VHz
0930	Auto IP	Ethernet
0255	Autotune Enable	Autotune
0256	Autotune Mode	Autotune
0274	Autotune Ramp Time	Autotune
0257	Autotune Test Disable	Autotune
0209	BACnet IP Device ID	BACnet IP
0208	BACnet IP State	BACnet IP
0210	BACnet IP Timeout	BACnet IP
0457	Base Frequency	Motor Nameplate
0991	Base IO FE State	Device State
0456	Base Voltage	Motor Nameplate
0992	Basic Drive FE State	Device State
0253	Brake Overrating	Braking

PNO	Parameter Name	Block
0252	Brake Rated Power	Braking
0251	Brake Resistance	Braking
0254	Braking Active	Braking
0249	Braking Enable	Braking
1251	CANopen Actual Baud	CANopen
0213	CANopen Baud Rate	CANopen
0212	CANopen Node Address	CANopen
0211	CANopen State	CANopen
1033	Card State	SD Card
0406	CM Temperature	Feedbacks
0217	CNet Consuming Inst	ControlNet
0216	CNet Producing Inst	ControlNet
0627	Comms Control Word	Sequencing
0051	Comms Diagnostic	Comms
0052	Comms Diagnostic Code	Comms
0186	Comms Event Active	Event
0188	Comms Event Clear	Event
0185	Comms Event Code	Event
0187	Comms Event Set	Event
0053	Comms Exception	Comms
0045	Comms Fitted	Comms
0050	Comms Module Serial	Comms
0049	Comms Module Version	Comms
0054	Comms Net Exception	Comms
0995	Comms Option FE State	Device State
1121	Comms Option Pcode	Drive info
1129	Comms Option Serial	Drive info
0681	Comms Reference	Sequencing
0044	Comms Required	Comms
0046	Comms State	Comms
0047	Comms Supervised	Comms
0048	Comms Trip Enable	Comms
0997	Config Fault Area	Device State
1116	Control Module Pcode	Drive info
0977	Control Module Serial	Drive info
0512	Control Strategy	Control Mode
0644	Control Word	Sequencing
0215	ControlNet MAC ID	ControlNet
0214	ControlNet State	ControlNet
0305	Current Limit	Current Limit
0329	DC Current Level	Inj Braking
0331	DC Inj Base Volts	Inj Braking
0326	DC Inj Current Limit	Inj Braking
0324	DC Inj Deflux Time	Inj Braking
0325	DC Inj Frequency	Inj Braking
0330	DC Inj Timeout	Inj Braking
0396	DC Link Volt Filtered	Feedbacks

PNO	Parameter Name	Block
0392	DC Link Voltage	Feedbacks
0327	DC Pulse Time	Inj Braking
0487	Deceleration Time	Ramp
0414	Deflux Delay	Pattern Generator
0221	DeviceNet Actual Baud	DeviceNet
0220	DeviceNet Baud Rate	DeviceNet
0219	DeviceNet MAC ID	DeviceNet
0218	DeviceNet State	DeviceNet
0929	DHCP	Ethernet
1269	DHCP State	Ethernet
0932	DHCP To Auto IP	Ethernet
0005	Digin Value	IO Values
0022	Digout Value	IO Values
0531	Direct Input Neg Lim	Spd Direct Input
0530	Direct Input Pos Lim	Spd Direct Input
0529	Direct Input Ratio	Spd Direct Input
0528	Direct Input Select	Spd Direct Input
0983	Display Timeout	Graphical Keypad
0223	DNet Consuming Inst	DeviceNet
0222	DNet Producing Inst	DeviceNet
0961	Drive Name	Drive info
0390	Duty Selection	Feedbacks
0408	Elec Rotor Speed	Feedbacks
0697	Enable 1 - 32	Trips Status
0383	Energy kWh	Energy Meter
0451	Energy Saving Enable	Fluxing VHz
0227	ENet Consuming Inst	EtherNet IP
0226	ENet Producing Inst	EtherNet IP
0224	EtherCAT State	EtherCAT
0937	Ethernet Diagnostic	Ethernet
0993	Ethernet FE State	Device State
0225	EtherNet IP State	EtherNet IP
0919	Ethernet State	Ethernet
0418	Fast Stop Torque Lim	Torque Limit
0918	Filtered VDC Ripple	VDC Ripple
0328	Final DC Pulse Time	Inj Braking
0509	Final Stop Rate	Ramp
1100	Firmware Version	Drive info
0696	First Trip	Trips Status
0447	Fixed Boost	Fluxing VHz
0202	Fixed Gateway Address	Option Ethernet
0200	Fixed IP Address	Option Ethernet
0201	Fixed Subnet Mask	Option Ethernet
0318	Flying Reflux Time	Flycatching
0312	Flying Start Mode	Flycatching
0938	Free Packets	Ethernet
0928	Gateway Address	Ethernet

PNO	Parameter Name	Block
1142	GKP Password	Graphical Keypad
0411	Heatsink Hot Warning	Feedbacks
0409	Heatsink OT Trip	Feedbacks
0410	Heatsink OT Warning	Feedbacks
0407	Heatsink Temperature	Feedbacks
0940	High Word First	Modbus
0232	High Word First RTU	Modbus RTU
0235	High Word First TCP	Modbus TCP
0397	id	Feedbacks
1048	IDE Version	App Info
0353	Inv Time Active	Stack Inv Time
0348	Inv Time Aiming Point	Stack Inv Time
0351	Inv Time Down Rate	Stack Inv Time
0349	Inv Time Output	Stack Inv Time
0350	Inv Time Up Rate	Stack Inv Time
0352	Inv Time Warning	Stack Inv Time
0996	IO Option FE State	Device State
1125	IO Option Pcode	Drive info
1134	IO Option Serial No	Drive info
1180	IO Option Status	IO Option Common
1254	IO Option SW Version	Drive info
1178	IO Option Type	IO Option Common
0926	IP Address	Ethernet
0207	IPConfig Enable	Option Ethernet
0398	iq	Feedbacks
0502	Jog Acceleration Time	Ramp
0503	Jog Deceleration Time	Ramp
0501	Jog Setpoint	Ramp
0994	Keypad FE State	Device State
1005	Language	Setup Wizard
0931	Last Auto IP Address	Ethernet
1047	Last Modification	App Info
0570	Leakage Inductance	Induction Motor Data
0591	Local	Sequencing
1255	Local Dir Key Active	Local Control
0592	Local Reference	Sequencing
1240	Local Reverse	Local Control
1239	Local Run Key Active	Local Control
1253	Local/Rem Key Active	Local Control
0344	Long Overload Level	Stack Inv Time
0345	Long Overload Time	Stack Inv Time
0920	MAC Address	Ethernet
0568	Magnetising Current	Induction Motor Data
0417	Main Torque Lim	Torque Limit
0913	Max VDC Ripple	VDC Ripple
0939	Maximum Connections	Modbus
0317	Min Search Speed	Flycatching
0229	Modbus Device Address	Modbus RTU
0230	Modbus RTU Baud Rate	Modbus RTU
0228	Modbus RTU State	Modbus RTU
0233	Modbus RTU Timeout	Modbus RTU
0234	Modbus TCP State	Modbus TCP
0236	Modbus TCP Timeout	Modbus TCP
0941	Modbus Timeout	Modbus
0942	Modbus Trip Enable	Modbus

PNO	Parameter Name	Block
0340	Mot I2T Active	Motor Load
0342	Mot I2T Enable	Motor Load
0338	Mot I2T TC	Motor Load
0341	Mot I2T Warning	Motor Load
0336	Mot Inv Time Active	Motor Load
0334	Mot Inv Time Delay	Motor Load
0337	Mot Inv Time Output %	Motor Load
0333	Mot Inv Time Over'l'd	Motor Load
0335	Mot Inv Time Warning	Motor Load
0374	Motor Base Volts	Voltage Control
0402	Motor Current	Feedbacks
0401	Motor Current Percent	Feedbacks
0458	Motor Poles	Motor Nameplate
0460	Motor Power	Motor Nameplate
0405	Motor Terminal Volts	Feedbacks
0511	Motor Type	Control Mode
0572	Mutual Inductance	Induction Motor Data
0459	Nameplate Speed	Motor Nameplate
0416	Negative Torque Lim	Torque Limit
1241	Open Connections	Modbus
0198	Option DHCP Enabled	Option Ethernet
0206	Option FTP Admin Mode	Option Ethernet
0205	Option FTP Enable	Option Ethernet
0197	Option Gateway	Option Ethernet
0195	Option IP Address	Option Ethernet
0189	Option MAC Address	Option Ethernet
0196	Option Subnet Mask	Option Ethernet
0203	Option Web Enable	Option Ethernet
0231	Parity And Stop Bits	Modbus RTU
1097	Password in Favourite	Graphical Keypad
1098	Password in Local	Graphical Keypad
0560	PMAC Back Emf Const KE	PMAC Motor Data
0693	PMAC Fly Active	PMAC Flycatching
0692	PMAC Fly Load Level	PMAC Flycatching
0690	PMAC Fly Search Model	PMAC Flycatching
0691	PMAC Fly Search Time	PMAC Flycatching
0694	PMAC Fly Setpoint	PMAC Flycatching
0689	PMAC Flycatching Enable	PMAC Flycatching
0556	PMAC Max Current	PMAC Motor Data
0555	PMAC Max Speed	PMAC Motor Data
0564	PMAC Motor Inertia	PMAC Motor Data
0559	PMAC Motor Poles	PMAC Motor Data
0557	PMAC Rated Current	PMAC Motor Data
0558	PMAC Rated Torque	PMAC Motor Data
0467	PMAC SVC Auto Values	PMAC SVC
0470	PMAC SVC I Gain Hz	PMAC SVC
0468	PMAC SVC LPF Speed Hz	PMAC SVC
0476	PMAC SVC Open Loop Strt	PMAC SVC
0469	PMAC SVC P Gain	PMAC SVC
0478	PMAC SVC Start Cur	PMAC SVC
0479	PMAC SVC Start Speed	PMAC SVC
0477	PMAC SVC Start Time	PMAC SVC
0565	PMAC Therm Time Const	PMAC Motor Data
0563	PMAC Torque Const KT	PMAC Motor Data
0562	PMAC Winding Inductance	PMAC Motor Data

PNO	Parameter Name	Block
0561	PMAC Winding Resistance	PMAC Motor Data
0415	Positive Torque Lim	Torque Limit
0461	Power Factor	Motor Nameplate
0386	Power Factor Angle Est	Energy Meter
0385	Power Factor Est	Energy Meter
0381	Power HP	Energy Meter
0380	Power kW	Energy Meter
0943	Process Active	Modbus
0238	Profibus Node Address	Profibus
0237	Profibus State	Profibus
0240	PROFINET Device Name	PROFINET IO
0239	PROFINET State	PROFINET IO
1054	Project Author	App Info
1068	Project Description	App Info
1040	Project Name	App Info
1061	Project Version	App Info
0508	Quickstop Ramp Time	Ramp
0507	Quickstop Time Limit	Ramp
0497	Ramp Hold	Ramp
0499	Ramp Spd Setpoint Input	Ramp
0500	Ramp Speed Output	Ramp
0485	Ramp Type	Ramp
0498	Ramping Active	Ramp
0413	Random Pattern IM	Pattern Generator
1268	Random Pattern PMAC	Pattern Generator
0455	Rated Motor Current	Motor Nameplate
1247	Ratio Load Mot Inert	Spd Loop Settings
0382	Reactive Power	Energy Meter
0055	Read Mapping[16]	Read Process
0895	Recent Trips[10]	Trips History
1265	Ref Max Speed Clamp	Speed Ref
1264	Ref Min Speed Clamp	Speed Ref
1266	Ref Speed Trim	Speed Ref
1267	Ref Trim Local	Speed Ref
0682	Reference	Sequencing
0307	Regen Limit Enable	Current Limit
0389	Reset Energy Meter	Energy Meter
0569	Rotor Time Constant	Induction Motor Data
0998	RTA Code	Device State
0999	RTA Data	Device State
1187	RTC Trim	General Purpose IO
1140	Run Key Action	Local Control
1006	Run Setup?	Setup Wizard
1001	Save All Parameters	Device Commands
0315	Search Boost	Flycatching
0313	Search Mode	Flycatching
0316	Search Time	Flycatching
0314	Search Volts	Flycatching
0527	Sel Torq Ctrl Only	Spd Loop Settings
1257	Seq Stop Method SVC	Ramp
0484	Seq Stop Method VHz	Ramp
0678	Sequencing State	Sequencing
0346	Short Overload Level	Stack Inv Time
0347	Short Overload Time	Stack Inv Time
0361	Slew Rate Accel Limit	Slew Rate

D-126 Parameter Reference

PNO	Parameter Name	Block
0362	Slew Rate Decel Limit	Slew Rate
0360	Slew Rate Enable	Slew Rate
0354	Slip Compensatn Enable	Slip Compensation
0356	SLP Motoring Limit	Slip Compensation
0357	SLP Regen Limit	Slip Compensation
0526	Spd Demand Neg Lim	Spd Loop Settings
0525	Spd Demand Pos Lim	Spd Loop Settings
0524	Spd Loop Adapt Pgain	Spd Loop Settings
0523	Spd Loop Adapt Thres	Spd Loop Settings
0521	Spd Loop Aux Torq Dmd	Spd Loop Settings
0519	Spd Loop Dmd Filt TC	Spd Loop Settings
0520	Spd Loop Fbk Filt TC	Spd Loop Settings
1246	Speed Loop Auto Set	Spd Loop Settings
1248	Speed Loop Bandwidth	Spd Loop Settings
0535	Speed Loop Error	Spd Loop Diagnostics
0516	Speed Loop I Time	Spd Loop Settings
0517	Speed Loop Int Defeat	Spd Loop Settings
0518	Speed Loop Int Preset	Spd Loop Settings
0515	Speed Loop Pgain	Spd Loop Settings
0536	Speed PI Output	Spd Loop Diagnostics
0491	Sramp Acceleration	Ramp
0490	Sramp Continuous	Ramp
0492	Sramp Deceleration	Ramp
0493	Sramp Jerk 1	Ramp
0494	Sramp Jerk 2	Ramp
0495	Sramp Jerk 3	Ramp
0496	Sramp Jerk 4	Ramp

PNO	Parameter Name	Block
0364	Stabilisation Enable	Stabilisation
0404	Stack Current (%)	Feedbacks
0412	Stack Frequency	Pattern Generator
1109	Stack Pcode	Drive info
1258	Stack Serial No	Drive info
0910	Stall Current Active	Stall Trip
0906	Stall Limit Type	Stall Trip
0911	Stall Speed Feedback	Stall Trip
0907	Stall Time	Stall Trip
0909	Stall Torque Active	Stall Trip
0982	Startup Page	Graphical Keypad
0571	Stator Resistance	Induction Motor Data
0661	Status Word	Sequencing
0504	Stop Ramp Time	Ramp
0927	Subnet Mask	Ethernet
0679	Switch On Timeout	Sequencing
0488	Symmetric Mode	Ramp
0489	Symmetric Time	Ramp
0419	Symmetric Torque Lim	Torque Limit
0988	Target State	Device State
0371	Terminal Voltage Mode	Voltage Control
1185	Thermistor Resistance	General Purpose IO
1004	Thermistor Trip Level	General Purpose IO
1184	Thermistor Type	General Purpose IO
1186	Time and Date	Real Time Clock
0534	Total Spd Demand %	Spd Loop Diagnostics
0533	Total Spd Demand RPM	Spd Loop Diagnostics

PNO	Parameter Name	Block
1002	Update Firmware	Device Commands
0935	User Gateway Address	Ethernet
0933	User IP Address	Ethernet
0934	User Subnet Mask	Ethernet
0311	VC Flying Start Enable	Flycatching
0912	VDC Ripple Filter TC	VDC Ripple
0917	VDC Ripple Level	VDC Ripple
0916	VDC Ripple Sample	VDC Ripple
0914	VDC Ripple Trip Delay	VDC Ripple
0915	VDC Ripple Trip Hyst	VDC Ripple
1143	Version	Graphical Keypad
0310	VHz Flying Start Enable	Flycatching
0422	VHz Shape	Fluxing VHz
0423	VHz User Freq[11]	Fluxing VHz
0435	VHz User Volts[11]	Fluxing VHz
1141	View Level	Graphical Keypad
0829	Warnings 1 - 32	Trips Status
0944	Web Access	Web Server
0204	Web Parameters Enable	Option Ethernet
0946	Web Password	Web Server
0945	Web View Level	Web Server
0120	Write Mapping[16]	Write Process
0506	Zero Speed Stop Delay	Ramp
0505	Zero Speed Threshold	Ramp

Appendix E: E Plan Library

E Plan Library

For information on the E Plan library go to www.eplan.co.uk web site.

To obtain layout diagrams from our E Plan Library go to www.parker.com/ssd and then click on “Support” then EPLAN Macro Downloads.

The screenshot shows a web browser window displaying the Parker Hannifin SSD Drives North America website. The browser's address bar shows the URL: <http://www.parker.com/portal/site/PARKER/menuitem.b0559799d3f5c315731910237ad1ca7vgnevtoad=37c1eeeb5ae2109gwCM10000048021deRCRD6vgnevtoad=EN>. The website header includes the Parker logo and navigation links: Home, Suppliers, Investor Relations, and Contact Us. A search bar is also present. The main navigation menu includes: Division Home, Products, Support, Literature, Where to Buy, About Us, and Contact Us. The 'Support' link is circled, and a line points from it to the text above. Below the navigation menu, the 'Support' section is expanded, showing a 'Customer Toolbox' with links for Software Downloads, U.S. Field Sales Territory Map, EPLAN Macro Downloads, Training Classes, and Release Policy and Form. Other sections include 'Catalogs and Literature' and 'Contact Us'. The footer contains copyright information for Parker Hannifin Corp. 2012 and links for Privacy Policies, Safety, ParkerStore™, and Site Map.

E-2 E Plan Library

Which then brings up the E Plan page.

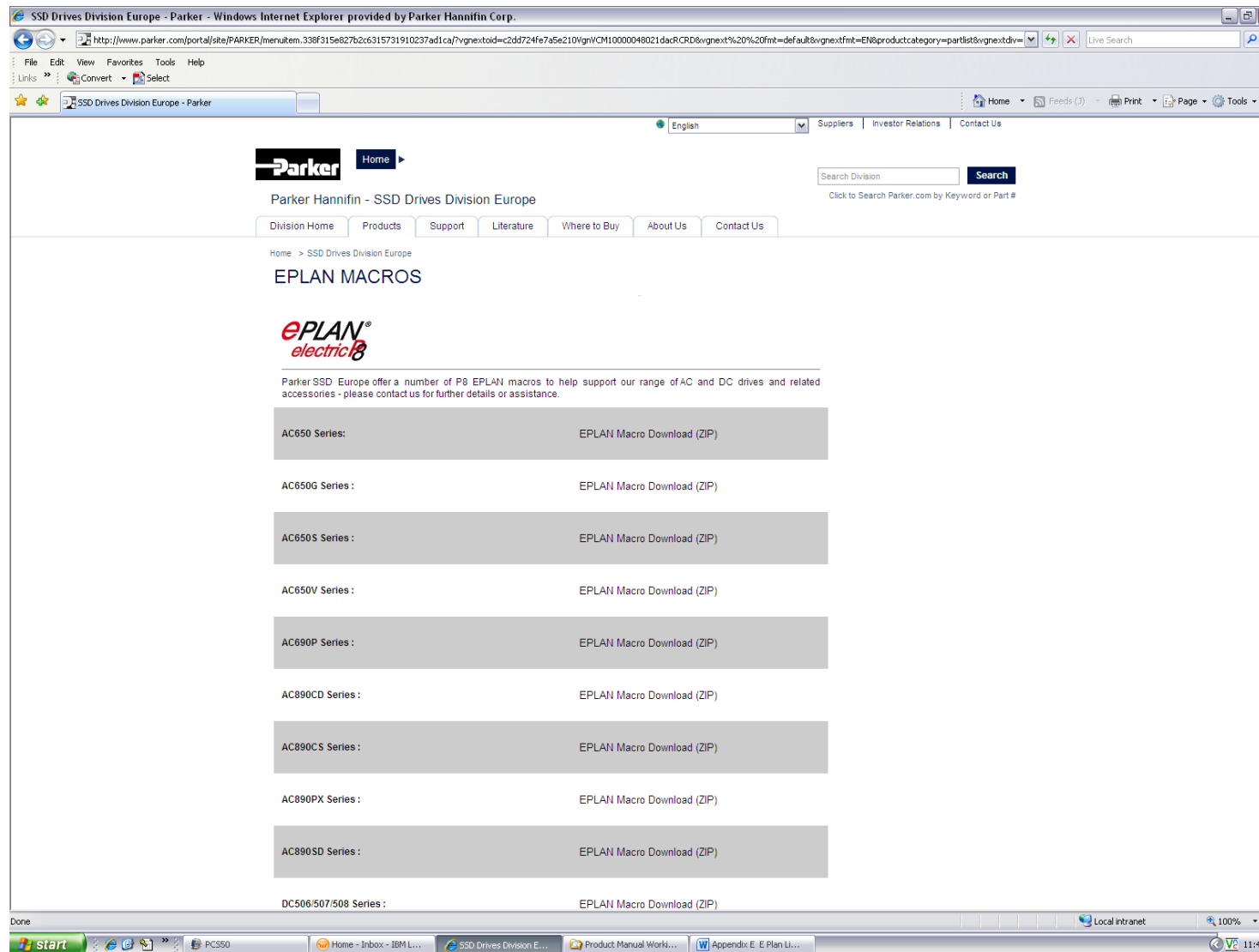

Appendix F: Technical Specifications

Understanding the Product Code

MODEL NUMBER

The unit is fully identified using a four block alphanumeric code which records how the drive was calibrated, and its various settings when dispatched from the factory. This can also be referred to as the Product Code.

Typical example: 31V-4D0004-BF-2S0000 (as shown in the example below).

This shows the product is an AC30V drive Frame D, IP21 standard suitable for fan and pump industry, rated at 400-480 Volts supply, 1.1kW (normal duty), with brake switch fitted, and Category C2 EMC filter, with GKP fitted with standard conformal coating and no special options.

Product Coding Scheme

	Block 1	Block 2	Block 3	Block 4																																																												
	3 1 V	4 D 0004	B F	2 S 0000																																																												
Family	AC30 Versatile Drive																																																															
IP Rating	IP Rating, IP21 SD IP Rating, IP54 SD IP Rating, Cold Plate SD IP Rating, IP21 CD IP Rating, IP54 CD IP Rating, Cold Plate CD																																																															
Industry	Industry, General Industry, Hydraulics Industry, Refrigeration																																																															
Supply voltage:	400V / 480V																																																															
Rating Data:	<table border="1"> <thead> <tr> <th rowspan="2">400V 3 phase supply</th> <th colspan="2">Normal Duty</th> <th colspan="2">Heavy Duty</th> <th rowspan="2">Frame Size</th> </tr> <tr> <th>kW</th> <th>hp</th> <th>kW</th> <th>hp</th> </tr> </thead> <tbody> <tr> <td>1.1</td> <td>1.5</td> <td>0.75</td> <td>1</td> <td>D</td> </tr> <tr> <td>1.5</td> <td>2</td> <td>1.1</td> <td>1.5</td> <td>D</td> </tr> <tr> <td>2.2</td> <td>3</td> <td>1.5</td> <td>2</td> <td>D</td> </tr> <tr> <td>3</td> <td></td> <td>2.2</td> <td>3</td> <td>D</td> </tr> <tr> <td>4</td> <td>5</td> <td>3</td> <td></td> <td>D</td> </tr> <tr> <td>5.5</td> <td>7.5</td> <td>4</td> <td>5</td> <td>D</td> </tr> <tr> <td>7.5</td> <td>10</td> <td>5.5</td> <td>7.5</td> <td>E</td> </tr> <tr> <td>11</td> <td>15</td> <td>7.5</td> <td>10</td> <td>E</td> </tr> <tr> <td>15</td> <td>20</td> <td>11</td> <td>15</td> <td>F</td> </tr> <tr> <td>18</td> <td>25</td> <td>15</td> <td>20</td> <td>F</td> </tr> </tbody> </table>				400V 3 phase supply	Normal Duty		Heavy Duty		Frame Size	kW	hp	kW	hp	1.1	1.5	0.75	1	D	1.5	2	1.1	1.5	D	2.2	3	1.5	2	D	3		2.2	3	D	4	5	3		D	5.5	7.5	4	5	D	7.5	10	5.5	7.5	E	11	15	7.5	10	E	15	20	11	15	F	18	25	15	20	F
400V 3 phase supply	Normal Duty		Heavy Duty			Frame Size																																																										
	kW	hp	kW	hp																																																												
1.1	1.5	0.75	1	D																																																												
1.5	2	1.1	1.5	D																																																												
2.2	3	1.5	2	D																																																												
3		2.2	3	D																																																												
4	5	3		D																																																												
5.5	7.5	4	5	D																																																												
7.5	10	5.5	7.5	E																																																												
11	15	7.5	10	E																																																												
15	20	11	15	F																																																												
18	25	15	20	F																																																												
Brake Switch	Not Fitted Brake switch fitted			N B																																																												
EMC filter	None Category C3 Category C2			N E F																																																												
GKP	Not Fitted Blank Fitted GKP Fitted			0 1 2																																																												
Conformal Coating	Standard 3C3 Enhanced			S E																																																												
Special Option	None			0000																																																												

EARTHING/SAFETY DETAILS	
Earthing	Permanent earthing is mandatory on all units. <ul style="list-style-type: none"> • Use a copper protective earth conductor 10mm² minimum cross-section, or install a second conductor in parallel with the protective conductor to a separate protective earth terminal • The conductor itself must meet local requirements for a protective earth conductor
Input Supply Details (TN) and (IT)	Drives without filters are suitable for earth referenced (TN) or non-earth referenced (IT) supplies. The drive is only suitable for earth referenced supplies (TN) when fitted with an internal filter. External filters are available for use on TN and IT (non-earth referenced) supplies.
Prospective Short Circuit Current (PSCC)	Refer to the appropriate Electrical Ratings table.
Earth Leakage Current	>10mA (all models)

INTERNAL COOLING FANS	
The forced-vent cooling of the drive is achieved by 1, or in some cases 2 fans. The Fan Rating gives the volume of air venting from the drive.	
Product	Fan Ratings
FRAME D	
All models	1 off 27 cfm (45m ³ /hr)
FRAME E	
All models	1 off 33 cfm (56m ³ /hr)
FRAME F	
All models	2 off 27 cfm (45m ³ /hr)

F-4 Technical Specifications

ELECTRICAL RATINGS (400V BUILD VARIANT)						
Power Supply = 380-480V ±10%, 50/60Hz ±5%						
Motor power, output current and input current must not be exceeded under steady state operating conditions.						
Product Code	Motor Power	Output Current (A)	Input Current (A)	Estimated Efficiency	Switching Frequency (kHz) nominal / maximum	Output Current Derate %/kHz
FRAME D : Input currents for kW ratings are at 400V 50Hz ac input and for Hp ratings at 460V 60Hz ac input. Prospective short circuit current 5kA.						
Normal Duty (Output Overload Motoring 110% for 60s)						
31V-4D0004...	1.1kW	3.5	4	95%	4 / 16	2.4%
	1.5Hp	3.0	3.5			
31V-4D0005...	1.5kW	4.5	5.3	96%	4 / 16	3.7%
	2Hp	3.4	4.5			
31V-4D0006...	2.2kW	5.5	7.6	97%	4 / 16	4.5%
	3Hp	4.8	6.4			
31V-4D0008...	3kW	7.5	6.5	97%	4 / 16	4.0%
31V-4D0010...	4kW	10.0	8.0	97%	4 / 16	3.9%
	5Hp	7.6	6.6			
31V-4D0012...	5.5kW	12.0	10.6	97%	4 / 16	3.5%
	7.5Hp	11	9.4			
Heavy Duty (Output Overload Motoring 150% for 60s, 180% for 0.5s short term rating)						
31V-4D0004...	0.75kW	2.5	2.9	95%	4 / 16	1.0%
	1Hp	2.1	2.4			
31V-4D0005...	1.1kW	3.5	4.0	95%	4 / 16	3.1%
	1.5Hp	3.0	3.5			
31V-4D0006...	1.5kW	4.5	5.3	96%	4 / 16	4.3%
	2Hp	3.4	4.5			
31V-4D0008...	2.2kW	5.5	5.2	97%	4 / 16	3.8%
	3Hp	4.8	4.6			
31V-4D0010...	3kW	7.5	6.5	97%	4 / 16	3.8%
31V-4D0012...	4kW	10.0	8.0	97%	4 / 16	3.3%
	5Hp	7.6	6.6			

ELECTRICAL RATINGS (400V BUILD VARIANT)						
Power Supply = 380-480V ±10%, 50/60Hz ±5%						
Motor power, output current and input current must not be exceeded under steady state operating conditions.						
Product Code	Motor Power	Output Current (A)	Input Current (A)	Estimated Efficiency	Switching Frequency (kHz) nominal / maximum	Output Current Derate %/kHz
FRAME E: Input currents for kW ratings are at 400V 50Hz ac input and for Hp ratings at 460V 60Hz ac input. Prospective short circuit current 5kA.						
Normal Duty (Output Overload Motoring 110% for 60s)						
31V-4E0016...	7.5kW	16	14.5	97%	4 / 16	5.5%
	10Hp	14	12.1			
31V-4E0023...	11kW	23	20.4	97%	4 / 16	5.1%
	15Hp	21	18.0			
Heavy Duty (Output Overload Motoring 150% for 30s, 180% for 0.5s short term rating)						
31V-4E0016...	5.5kW	12	10.7	97%	4 / 16	4.9%
	7.5Hp	11	9.5			
31V-4E0023...	7.5kW	16	14.5	97%	4 / 16	4.9%
	10Hp	14	12.7			
FRAME F: Input currents for kW ratings are at 400V 50Hz ac input and for Hp ratings at 460V 60Hz ac input. Prospective short circuit current 5kA.						
Normal Duty (Output Overload Motoring 110% for 60s)						
31V-4F0032...	15kW	32	28.5	97%	4 / 12	6.3%
	20Hp	27	24.5			
31V-4F0038...	18.5kW	38	33.5	97%	4 / 12	6.7%
	25Hp	36	30.2			
Heavy Duty (Output Overload Motoring 150% for 60s, 180% for 0.5s short term rating)						
31V-4F0032...	11kW	23	21.7	97%	4 / 12	6.0%
	15Hp	21	19.1			
31V-4F0038...	15kW	32	28.5	97%	4 / 12	6.1%
	20Hp	27	24.5			

F-6 Technical Specifications

INPUT FUSE RATINGS (EUROPE)					
Product Code	Input Fuse Rating (A)		Product Code	Input Fuse Rating (A)	
	NORMAL DUTY			NORMAL DUTY	
400V BUILD VARIANT 380-480V ±10%, 50/60Hz ±5%*					
Frame D			Frame E		
31V-4D0004...	10A		31V-4E0016...	20A	
31V-4D0005...	10A		31V-4E0023...	25A	
31V-4D0006...	10A		Frame F		
31V-4D0008...	10A		31V-4F0032...	32A	
31V-4D0010...	12A		31V-4F0038...	40A	
31V-4D0012...	16A				

INPUT FUSE RATINGS (NORTH AMERICA AND CANADA)					
Product Code	Input Fuse Rating (A)		Product Code	Input Fuse Rating (A)	
400V BUILD VARIANT 380-480V ±10%, 50/60HZ *					
Frame D			Frame E		
31V-4D0004...	6A	CS470754U006	31V-4E0016...	25A	CS470754U025
31V-4D0005...	10A	CS470754U010	31V-4E0023...	30A	CS470754U030
31V-4D0006...	10A	CS470754U010	Frame F		
31V-4D0008...	12A	CS470754U012	31V-4F0032...	40A	CS470754U040
31V-4D0010...	12A	CS470754U012	31V-4F0038...	50A	CS470754U050
31V-4D0012...	20A	CS470754U020			

FRAME D INTERNAL DYNAMIC BRAKE SWITCH						
Product Code	Motor Power (kW/hp)	Brake Switch Peak Current (A)	Peak Brake Dissipation (kW/hp)	Brake Switch Continuous Current (A)	Continuous Brake Dissipation (kW/hp)	Minimum Brake Resistor Value (Ω)
		20s maximum, 30% duty				
400V Build Variant: 380-480V \pm10%, 50/60Hz \pm5% DC link brake voltage: 765V						
31V-4D0004...	1.1/1.5	1.5A	1.1/1.5	1	0.75/1	520
31V-4D0005...	1.5/2	2.2A	1.7/2.3	1.4	1.1/1.5	355
31V-4D0006...	2.2/3	2.9A	2.3/3	2	1.5/2	260
31V-4D0008...	3/	4.3A	3.3/4.5	2.9	2.2/3	177
31V-4D0010...	4/5	5.9A	4.5/	3.9	3/	130
31V-4D0012...	5.5/7.5	7.8A	6/7.5	5.2	4/5	98

FRAME E INTERNAL DYNAMIC BRAKE SWITCH						
Product Code	Motor Power (kW/hp)	Brake Switch Peak Current (A)	Peak Brake Dissipation (kW/hp)	Brake Switch Continuous Current (A)	Continuous Brake Dissipation (kW/hp)	Minimum Brake Resistor Value (Ω)
		20s maximum, 30% duty				
400V Build Variant: 380-480V \pm10%, 50/60Hz \pm5% DC link brake voltage: 765V						
31V-4E0016...	7.5/10	10.8A	8.25/11.25	7.2	5.5/7.5	71
31V-4E0023...	11/15	14.7A	11.25/15	9.8	7.5/10	52

FRAME F INTERNAL DYNAMIC BRAKE SWITCH						
Product Code	Motor Power (kW/hp)	Brake Switch Peak Current (A)	Peak Brake Dissipation (kW/hp)	Brake Switch Continuous Current (A)	Continuous Brake Dissipation (kW/hp)	Minimum Brake Resistor Value (Ω)
		20s maximum, 30% duty				
400V Build Variant: 380-480V \pm10%, 50/60Hz \pm5% DC link brake voltage: 765V						
31V-4F0032...	15/20	21.5A	16.5/22.5	14.4	11/15	35
31V-4F0038...	18/25	29.4A	22.5/30	19.6	15/20	26

F-8 Technical Specifications

SUPPLY SHORT CIRCUIT RATING

The following drives when fitted with UL Listed fuses are suitable for use on a circuit capable of delivering not more than:

Frame D: 5,000 RMS Symmetrical Amperes, 480V maximum

Frame E: 5,000 RMS Symmetrical Amperes, 480V maximum

Frame F: 5,000 RMS Symmetrical Amperes, 480V maximum

Refer to Appendix C: "Compliance" – Solid –State Short Circuit Protection

When group installed with the specified line reactor frame D, E and F sizes may be used on a supply rating delivering not more than 50,000 RMS Symmetrical amperes, 480V maximum, see table below for further information:

380-480V

Frame Size	Motor Power	Parker Part Number	MTE Part Number	Inductance mH	Rated amps
D	1.1kW / 1.5hp	CO470651	RL-00402	6.5	2
D	1.5kW / 2hp	CO470651	RL-00402	6.5	2
D	2.2kW / 3hp	CO352782	RL-00803	5	8
D	3kW	CO352782	RL-00803	5	8
D	4kW / 5hp	CO470652	RL-00802	3	8
D	5.5kW / 7.5hp	CO352783	RL-01202	2.5	12
E	7.5kW / 10hp	CO352785	RL-01802	2.5	18
E	11kW / 15hp	CO352786	RL-02502	1.2	25
F	15kW / 20hp	CO532901	RL-03502	0.8	35
F	18kW / 25hp	CO352901	RL-03502	0.8	35

ANALOG INPUTS/OUTPUTS <i>AIN1 (X11/01), AIN2 (X11/02)</i> <i>AOUT1 (X11/03), AOUT2 (X11/04)</i> <i>conforming to EN61131-2</i>		
	Inputs	Output
Range	AIN1: Range selected by parameter 0001 from: 0 to 10V, -10V to +10V, 0 to 20mA, 4 to 20mA AIN2: Range selected by parameter 0002 from: 0 to 10V, -10V to +10V Absolute maximum input current 25mA in current mode (AIN1 only) Absolute maximum input voltage $\pm 24V$ dc in voltage mode	AOUT1: Range selected by parameter 0003 from: 0 to 10V, -10V to +10V AOUT2: Range selected by parameter 0004 from: 0 to 10V, 0 to 20mA, 4 to 20mA Maximum rated output current in voltage mode 10mA, with short circuit protection
Impedance	Input impedance: Voltage range = 22k Ω Current range = 120R	Load impedance : Voltage range $\geq 1k\Omega$ Current range $\leq 600\Omega$
Resolution	12 bits (1 in 4096) over full range	11 bits (1 in 2048)
Accuracy	Better than $\pm 1\%$	Better than $\pm 1\%$
Sample / Update Rate	1ms	1ms

REFERENCE OUTPUTS <i>+10VREF (X11/05)</i> <i>-10VREF (X11/06)</i>	
Output Voltage	+10V and -10V
Accuracy	Better than $\pm 0.5\%$
Output Current	$\leq 10mA$
Overload / Short Circuit Protection	Indefinite

F-10 Technical Specifications

DIGITAL INPUTS <i>DIN1 (X13/02) – DIN3 (X13/04)</i> <i>DIO1 (X12/01) – DIO4 (X12/04)</i> conforming to EN61131-2													
Nominal Rated Voltage	24V												
Operating Range	DIN1, DIN2, DIN3, DIO1, DIO2, DIO3, DIO4: 0-5V dc = OFF, 15-24V dc = ON (absolute maximum input voltage $\pm 30V$ dc) <div style="float: right; margin-left: 20px;"> <table style="border-collapse: collapse;"> <tr> <td style="border: none; padding-right: 5px;">24V</td> <td style="border: none;">┌</td> <td style="border: none;">ON</td> </tr> <tr> <td style="border: none; padding-right: 5px;">15V</td> <td style="border: none;">├</td> <td style="border: none;">undefined state</td> </tr> <tr> <td style="border: none; padding-right: 5px;">5V</td> <td style="border: none;">├</td> <td style="border: none;">OFF</td> </tr> <tr> <td style="border: none; padding-right: 5px;">0V</td> <td style="border: none;">└</td> <td style="border: none;"></td> </tr> </table> </div>	24V	┌	ON	15V	├	undefined state	5V	├	OFF	0V	└	
24V	┌	ON											
15V	├	undefined state											
5V	├	OFF											
0V	└												
Input Threshold	Typically 10V												
Input Impedance	3.3k Ω												
Input Current	7.3mA \pm 10% @ 24V												
Sample Interval	1ms												

DIGITAL OUTPUTS <i>DIO1 (X12/01) – DIO4 (X12/04)</i> conforming to EN61131-2	
Nominal Open Circuit Output Voltage	24V (minimum 21V)
Rated Output Current	140mA : The total current available is 140mA, either individually or as the sum of all digital outputs and User +24V Supply.
Overload / Short Circuit Protection	Indefinite

USER 24V SUPPLY (X13/05)	
Nominal Open Circuit Output Voltage	24V (minimum 21V)
Rated Output Current	140mA : The total current available is 140mA, either individually or as the sum of all digital outputs and User +24V Supply.
Overload / Short Circuit Protection	Indefinite

RELAYS	
<p><i>RL1 (X14/01 – X14/02)</i> <i>RL2 (X14/03 – X14/04)</i> <i>These are volt-free relay contacts</i></p>	
Maximum Voltage	250V ac or 30V dc Protection against inductive or capacitive loads must be provided externally.
Maximum Current	3A resistive load

Parker Worldwide

AE – UAE, Dubai

Tel: +971 4 8127100

parker.me@parker.com

AR – Argentina, Buenos Aires

Tel: +54 3327 44 4129

AT – Austria, Wiener Neustadt

Tel: +43 (0)2622 23501-0

parker.austria@parker.com

AT – Eastern Europe, Wiener Neustadt

Tel: +43 (0)2622 23501 900

parker.easteurope@parker.com

parker.easteurope@parker.com

AU – Australia, Castle Hill

Tel: +61 (0)2-9634 7777

AZ – Azerbaijan, Baku

Tel: +994 50 2233 458

parker.azerbaijan@parker.com

BE/LU – Belgium, Nivelles

Tel: +32 (0)67 280 900

parker.belgium@parker.com

BR – Brazil, Cachoeirinha RS

Tel: +55 51 3470 9144

BY – Belarus, Minsk

Tel: +375 17 209 9399

parker.belarus@parker.com

CA – Canada, Milton, Ontario

Tel: +1 905 693 3000

CH – Switzerland, Etoy

Tel: +41 (0)21 821 87 00

parker.switzerland@parker.com

CL – Chile, Santiago

Tel: +56 2 623 1216

CN – China, Shanghai

Tel: +86 21 2899 5000

CZ – Czech Republic, Klecany

Tel: +420 284 083 111

parker.czechrepublic@parker.com

DE – Germany, Kaarst

Tel: +49 (0)2131 4016 0

parker.germany@parker.com

DK – Denmark, Ballerup

Tel: +45 43 56 04 00

parker.denmark@parker.com

ES – Spain, Madrid

Tel: +34 902 330 001

parker.spain@parker.com

FI – Finland, Vantaa

Tel: +358 (0)20 753 2500

parker.finland@parker.com

FR – France, Contamine s/Arve

Tel: +33 (0)4 50 25 80 25

parker.france@parker.com

GR – Greece, Athens

Tel: +30 210 933 6450

parker.greece@parker.com

HK – Hong Kong

Tel: +852 2428 8008

HU – Hungary, Budapest

Tel: +36 1 220 4155

parker.hungary@parker.com

IE – Ireland, Dublin

Tel: +353 (0)1 466 6370

parker.ireland@parker.com

IN – India, Mumbai

Tel: +91 22 6513 7081-85

IT – Italy, Corsico (MI)

Tel: +39 02 45 19 21

parker.italy@parker.com

JP – Japan, Tokyo

Tel: +81 (0)3 6408 3901

KR – South Korea, Seoul

Tel: +82 2 559 0400

KZ – Kazakhstan, Almaty

Tel: +7 7272 505 800

parker.easteurope@parker.com

MX – Mexico, Apodaca

Tel: +52 81 8156 6000

MY – Malaysia, Shah Alam

Tel: +60 3 7849 0800

NL – The Netherlands, Oldenzaal

Tel: +31 (0)541 585 000

parker.nl@parker.com

NO – Norway, Asker

Tel: +47 66 75 34 00

parker.norway@parker.com

NZ – New Zealand, Mt Wellington

Tel: +64 9 574 1744

PL – Poland, Warsaw

Tel: +48 (0)22 573 24 00

parker.poland@parker.com

PT – Portugal, Leca da Palmeira

Tel: +351 22 999 7360

parker.portugal@parker.com

RO – Romania, Bucharest

Tel: +40 21 252 1382

parker.romania@parker.com

RU – Russia, Moscow

Tel: +7 495 645-2156

parker.russia@parker.com

SE – Sweden, Spånga

Tel: +46 (0)8 59 79 50 00

parker.sweden@parker.com

SG – Singapore

Tel: +65 6887 6300

SK – Slovakia, Banská Bystrica

Tel: +421 484 162 252

parker.slovakia@parker.com

SL – Slovenia, Novo Mesto

Tel: +386 7 337 6650

parker.slovenia@parker.com

TH – Thailand, Bangkok

Tel: +662 717 8140

TR – Turkey, Istanbul

Tel: +90 216 4997081

parker.turkey@parker.com

TW – Taiwan, Taipei

Tel: +886 2 2298 8987

UA – Ukraine, Kiev

Tel: +380 44 494 2731

parker.ukraine@parker.com

UK – United Kingdom, Warwick

Tel: +44 (0)1926 317 878

parker.uk@parker.com

US – USA, Cleveland

Tel: +1 216 896 3000

VE – Venezuela, Caracas

Tel: +58 212 238 5422

ZA – South Africa, Kempton Park

Tel: +27 (0)11 961 0700

parker.southafrica@parker.com

European Product Information Centre

Free phone: 00 800 27 27 5374

(from AT, BE, CH, CZ, DE, EE, ES, FI, FR, IE, IL, IS, IT,

LU, MT, NL, NO, PT, SE, SK, UK)

**Parker Hannifin Manufacturing Limited
Automation Group, SSD Drives Europe,**

New Courtwick Lane,
Littlehampton, West Sussex. BN17 7RZ

Office: +44 (0)1903 737000

Fax: +44 (0)1903 737100

www.parker.com/ssd