



# Option Modules

## General Purpose IO Option (GPIO)

HA501836U001 Issue 2  
Technical Manual

aerospace  
climate control  
electromechanical  
filtration  
fluid & gas handling  
hydraulics  
pneumatics  
process control  
sealing & shielding



ENGINEERING YOUR SUCCESS





---

# AC30/AC70 General Purpose I/O Option

## Technical Manual HA501836 Issue 2

Compatible with Version 1.x software

Copyright 2013 Parker Hannifin Manufacturing Limited

All rights strictly reserved. No part of this document may be stored in a retrieval system, or transmitted in any form or by any means to persons not employed by a Parker company without written permission from Parker Hannifin Ltd. Although every effort has been taken to ensure the accuracy of this document it may be necessary, without notice, to make amendments or correct omissions. Parker cannot accept responsibility for damage, injury, or expenses resulting therefrom.

Parker Hannifin Manufacturing Limited is referred to throughout this document as Parker.

### **WARRANTY**

The general terms and conditions of sale of goods and/or services of Parker Hannifin Europe Sarl's, Luxembourg, Switzerland Branch, Etoy, apply to this product unless otherwise agreed. The terms and conditions are available on our website [www.parker.com/termsandconditions/switzerland](http://www.parker.com/termsandconditions/switzerland).



**FAILURE OR IMPROPER SELECTION OR IMPROPER USE OF THE PRODUCTS DESCRIBED HEREIN OR RELATED ITEMS CAN CAUSE DEATH, PERSONAL INJURY AND PROPERTY DAMAGE.**

This document and other information from Parker-Hannifin Corporation, its subsidiaries and authorized distributors provide product or system options for further investigation by users having technical expertise.

The user, through its own analysis and testing, is solely responsible for making the final selection of the system and components and assuring that all performance, endurance, maintenance, safety and warning requirements of the application are met. The user must analyze all aspects of the application, follow applicable industry standards, and follow the information concerning the product in the current product catalog and in any other materials provided from Parker or its subsidiaries or authorized distributors.

To the extent that Parker or its subsidiaries or authorized distributors provide component or system options based upon data or specifications provided by the user, the user is responsible for determining that such data and specifications are suitable and sufficient for all applications and reasonably foreseeable uses of the components or systems.

# Safety Information



## Requirements

**IMPORTANT:** Please read this information *BEFORE* installing the equipment.

### Intended Users

This manual is to be made available to all persons who are required to install, configure or service equipment described herein, or any other associated operation.

The information given is intended to highlight safety issues, EMC considerations, and to enable the user to obtain maximum benefit from the equipment.

Complete the following table for future reference detailing how the unit is to be installed and used.

INSTALLATION DETAILS	
<b>Model Number</b> <i>(see product label)</i>	
<b>Where installed</b> <i>(for your own information)</i>	

### Application Area

The equipment described is intended for industrial motor speed control utilising AC induction or AC synchronous machines

### Personnel

Installation, operation and maintenance of the equipment should be carried out by competent personnel. A competent person is someone who is technically qualified and familiar with all safety information and established safety practices; with the installation process, operation and maintenance of this equipment; and with all the hazards involved.

### Product Warnings

 <b>DANGER</b> Risk of electric shock	 <b>WARNING</b> Hot surfaces	 <b>Caution</b> Refer to documentation	 <b>Earth/Ground</b> Protective Conductor Terminal
--	---	---	---

## CAUTION!

### APPLICATION RISK

- The specifications, processes and circuitry described herein are for guidance only and may need to be adapted to the user's specific application. We cannot guarantee the suitability of the equipment described in this Manual for individual applications.

### RISK ASSESSMENT

Under fault conditions, power loss or unintended operating conditions, the drive may not operate as intended. In particular:

- Stored energy might not discharge to safe levels as quickly as suggested, and can still be present even though the drive appears to be switched off
- The motor's direction of rotation might not be controlled
- The motor speed might not be controlled
- The motor might be energised
- Stored energy
- Supply disconnects
- Sequencing logic
- Unintended operation

## Safety Information



### **DANGER! - Ignoring the following may result in injury**

1. This equipment can endanger life by exposure to rotating machinery and high voltages.
2. The equipment must be permanently earthed due to the high earth leakage current, and the drive motor must be connected to an appropriate safety earth.
3. Ensure all incoming supplies are isolated before working on the equipment. Be aware that there may be more than one supply connection to the drive.
4. There may still be dangerous voltages present at power terminals (motor output, supply input phases, DC bus and the brake, where fitted) when the motor is at standstill or is stopped.
5. For measurements use only a meter to IEC 61010 (CAT III or higher). Always begin using the highest range. CAT I and CAT II meters must not be used on this product.
6. Allow at least 5 minutes for the drive's capacitors to discharge to safe voltage levels (<50V). Use the specified meter capable of measuring up to 1000V dc & ac rms to confirm that less than 50V is present between all power terminals and between power terminals and earth.
7. Unless otherwise stated, this product must NOT be dismantled. In the event of a fault the drive must be returned. Refer to "Routine Maintenance and Repair".

### **WARNING! - Ignoring the following may result in injury or damage to equipment**

#### **SAFETY**

**Where there is conflict between EMC and Safety requirements, personnel safety shall always take precedence.**

- Never perform high voltage resistance checks on the wiring without first disconnecting the drive from the circuit being tested.
- Whilst ensuring ventilation is sufficient, provide guarding and /or additional safety systems to prevent injury or damage to equipment.
- When replacing a drive in an application and before returning to use, it is essential that all user defined parameters for the product's operation are correctly installed.
- All control and signal terminals are SELV, i.e. protected by double insulation. Ensure all external wiring is rated for the highest system voltage.
- Thermal sensors contained within the motor must have at least basic insulation.
- All exposed metalwork in the Inverter is protected by basic insulation and bonded to a safety earth.
- RCDs are not recommended for use with this product but, where their use is mandatory, only Type B RCDs should be used.

#### **EMC**

- In a domestic environment this product may cause radio interference in which case supplementary mitigation measures may be required.
- This equipment contains electrostatic discharge (ESD) sensitive parts. Observe static control precautions when handling, installing and servicing this product.
- This is a product of the restricted sales distribution class according to IEC 61800-3. It is designated as "professional equipment" as defined in EN61000-3-2. Permission of the supply authority shall be obtained before connection to the low voltage supply.

**AC30 General Purpose I/O Option..... 1**

- Introduction ..... 1
- Understanding the Product Code ..... 1
- Installation..... 2
- User Terminals..... 4
- Product Specification ..... 5
- Digital Inputs and Outputs (7004-01-00 only) ..... 6
  - Port Configuration..... 7
  - Programming..... 8
  - Specifications ..... 10
  - Example Applications ..... 11
- Analogue Inputs (7004-01-00 only) ..... 12
  - Programming..... 13
  - Specification ..... 13
  - Example Application ..... 14
- Motor Thermistor (7004-01-00, 7004-02-00 and 7004-03-00)..... 15
  - Programming..... 15
  - Specification ..... 16
  - Example Application ..... 16
- Volt-free Relays (7004-01-00 only)..... 17
  - Programming..... 17
  - Specification ..... 18
  - Example application..... 18
- Real-Time Clock (7004-01-00 and 7004-03-00) ..... 19
  - Programming..... 19
  - Specification ..... 19
- Environmental..... 21
  - Restriction, Evaluation, Authorisation and Restriction of Chemicals (REACH) ..... 21
  - Restriction of Hazardous Substances (RoHS)..... 21
  - Waste Electrical and Electronic Equipment (WEEE) ..... 22





# AC30/AC70 GENERAL PURPOSE I/O OPTION

## Introduction

---

The General Purpose I/O Option Modules, referred to throughout as GPIO, is a range of option modules compatible with the AC30 range of drives. They offer a variety of I/O expansion, according to the full product code.

## Understanding the Product Code

---

The GPIO product codes are 7004-XX-00 and are available with different features:

Product Code	Features available
7004-01-00	4 x Digital Inputs or Outputs 3 x Analogue Inputs 1 x Motor Thermistor Input 2 x Volt-free Relay Outputs Real-Time Clock
7004-02-00	1 x Motor Thermistor Input
7004-03-00	1 x Motor Thermistor Input Real-Time Clock
7004-XX-00	Standard optimized minimal conformal coating



## Installation

1. Refer to the AC30 product manual Chapter 1: Safety before installing or removing a GPIO option.
2. Ensure all power is removed from the drive.
3. Remove the GKP by pulling from the top down, and remove.

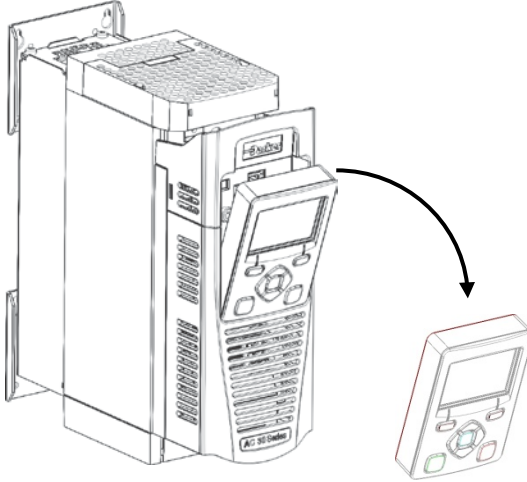

4. After removing the screw, slide the VCM lower cover down slightly and then remove.

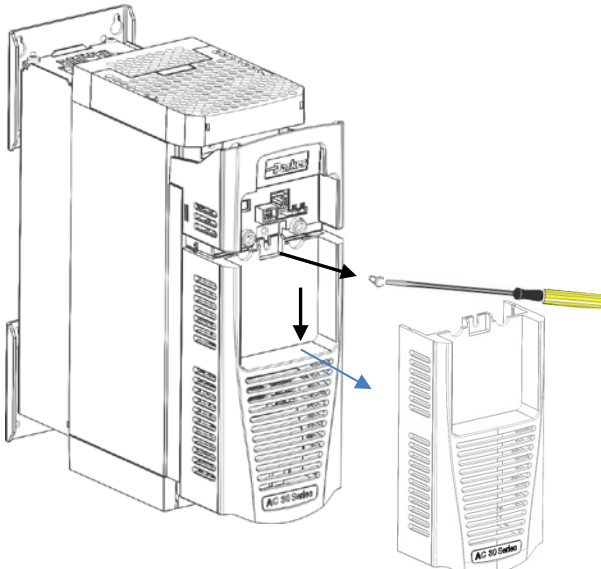

5. Click the Option into place and tighten the retaining screw, as shown.

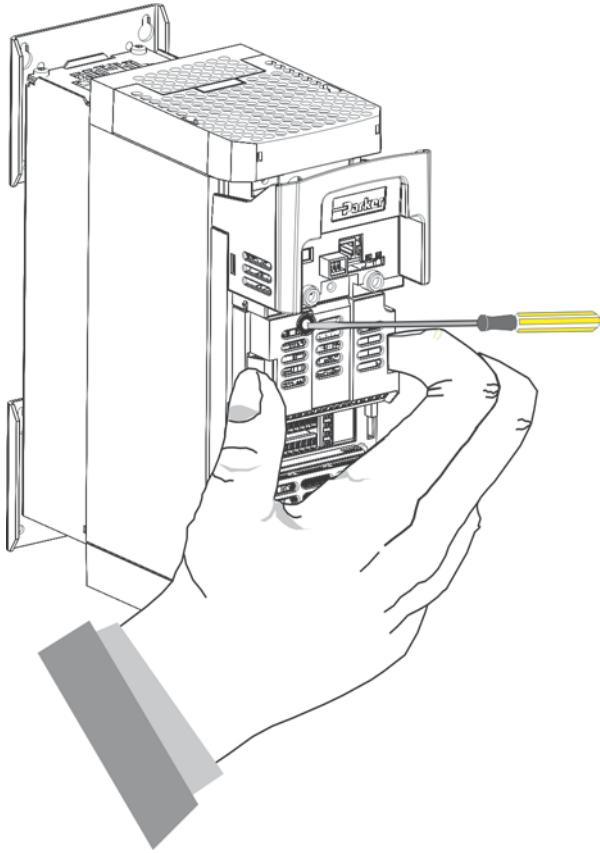

6. Slide and click back the VCM lower cover, tighten the retaining screw and slot back the GKP.

## User Terminals

---

The GPIO range contains blocks of user terminals, as shown below.

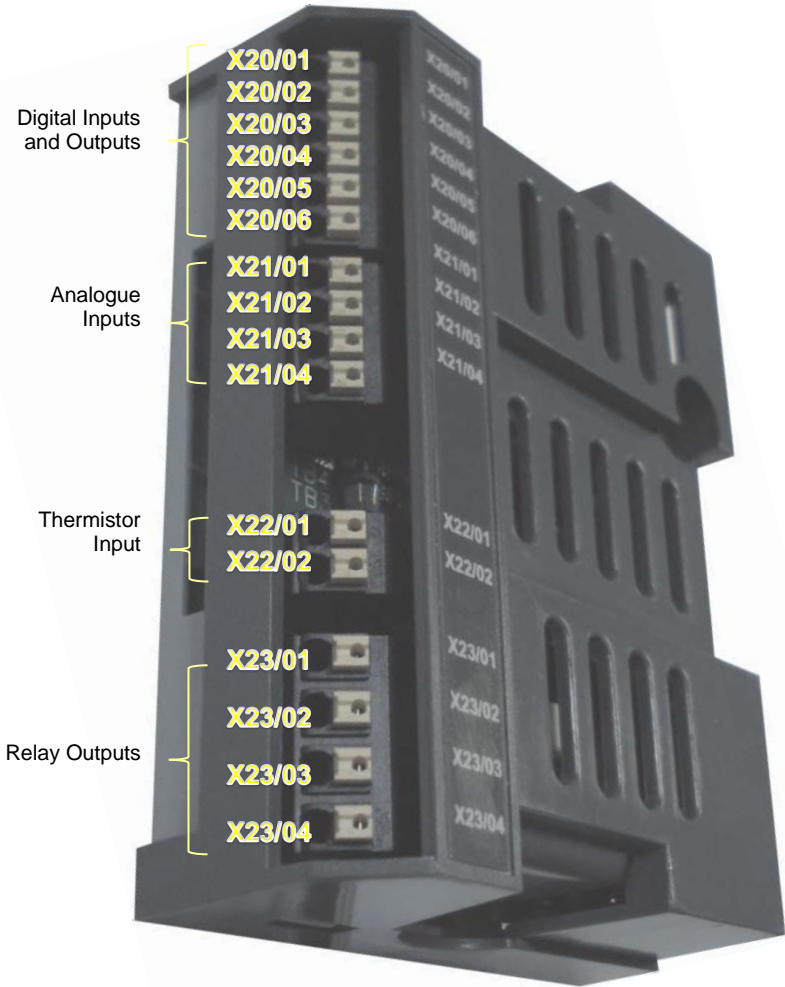

## Product Specification

---

Power consumption (internal)	Sourced from drive's internal supplies. Its purpose is to power the option module, except digital outputs.	Maximum consumption (7004-01-00) = 1W
------------------------------	--	---------------------------------------

Power consumption (external)	Sourced from user supply. Its purpose is to power digital outputs.	Maximum consumption (7004-01-00 only) = 500mA @ 24V
------------------------------	--	---

# 6

## Digital Inputs and Outputs (7004-01-00 only)

The GPIO option 7004-01-00 offers four identical ports on X20 that can be individually configured as digital input or digital output.

Terminal	Name	Range	Description	
X20	01	DIN11 / DOUT11	0 to 24VDC	Digital Input / Output 11 (default = unassigned input). See the notes below.
	02	DIN12 / DOUT12	0 to 24VDC	Digital Input / Output 12 (default = unassigned input). See the notes below.
	03	DIN13 / DOUT13	0 to 24VDC	Digital Input / Output 13 (default = unassigned input). See the notes below.
	04	DIN14 / DOUT14	0 to 24VDC	Digital Input / Output 14 (default = unassigned input). See the notes below.
	05	+24V DC IN	24V ± 10%	24V DC Input. Required to power digital outputs DOUT11 to DOUT14. See the notes below.
	06	DIG 0V	0V	0V reference for 7004-01- XXX Digital Inputs and Outputs. See the notes below.

### Note 1:

If any of X20/01 to X20/04 is to be configured as digital output, then X20/05 must be connected to the positive output from a 24V supply, and X20/06 must be connected to the negative output from the same supply. See the example applications on page 11.

### Note 2:

Digital input and output ports on the 7004-01-00 are fully isolated from the drive electronics. Therefore it is essential that X20/06 is connected to the user's 0V signal reference which should be grounded at an appropriate point in the system.

## Port Configuration

Each port can be configured individually as an input or an output. The following paragraphs describe how to specify the ports' directions.

The diagram below shows the equivalent circuit for port DIN11 / DOUT11. The other 3 ports are identical.

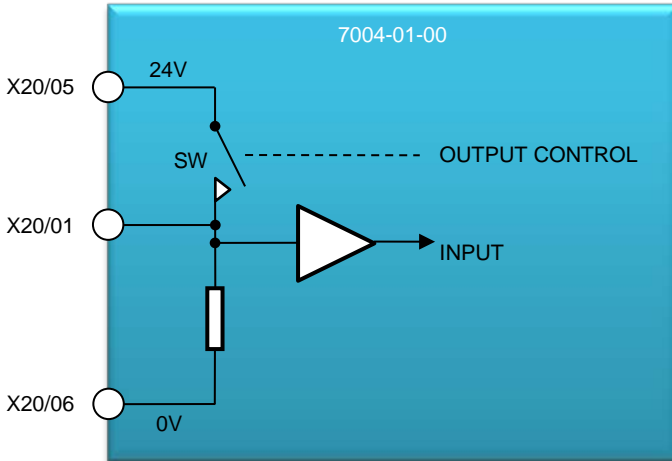

### **Configure a port as output**

The user must provide 24V to X20/05, and 0V to X20/06 from an external power supply.

OUTPUT CONTROL is a signal within the 7004-01-00 that can be configured by the user, and INPUT is a signal within the 7004-01-00 that can be monitored by the user.

If OUTPUT CONTROL is ON, switch SW is closed, and X20/01 outputs a high level (+24V).

If OUTPUT CONTROL is OFF, switch SW is open, and the resistor pulls X20/01 low (0V).

INPUT always reports the logic level at the user terminal.

### **Configure a port as input**

To select a port as an input, OUTPUT CONTROL must be OFF. Then if the user applies 24V to X20/01, INPUT reports a high level. If the user applies 0V, or open circuit to X20/01, INPUT reports a low level.

## Programming

### Output Ports

The four outputs are included in parameter number 0022.

Parameter	Access	Bit	Value	Description
0022	Write or Read	00 to 07	x	These bits control digital outputs on the base I/O.
		08	0	DOUT11 = low level output, or port is configured as input.
			1	DOUT11 = high level output
		09	0	DOUT12 = low level output, or port is configured as input.
			1	DOUT12 = high level output
		10	0	DOUT13 = low level output, or port is configured as input.
			1	DOUT13 = high level output
		11	0	DOUT14 = low level output, or port is configured as input.
			1	DOUT14 = high level output
		12 to 13	x	Unused. Value = don't care
14, 15	x	These control relay outputs on the GPIO. See page 17.		



**Input Ports**

The four inputs are included in parameter 0005.

Parameter	Access	Bit	Value	Description
0005	Read only	00 to 07	x	Used by functions on the base I/O
		08	0	DIN11 is low
			1	DIN11 is high
		09	0	DIN12 is low
			1	DIN12 is high
		10	0	DIN13 is low
			1	DIN13 is high
		11	0	DIN14 is low
			1	DIN14 is high
		12 to 15	0	Not used. Value is always 0

## Specifications

### *Digital Inputs DIN11 to DIN14*

Feature	Value
Normal operating voltage	0 to 24V relative to terminal X20/06
Absolute maximum input voltage	-30V to +30V relative to terminal X20/06
Input threshold	Between 5V and 15V relative to terminal X20/06
Input hysteresis	None
Input current	8mA to 12mA @ 24V DC
Sample rate	1ms
Isolation	DIN11 to DIN14 are optically isolated from drive electronics, but not from other 7004-01-00 Digital Inputs / Outputs. Isolation is functional only, intended to eliminate ground loops. It is not a safety isolation barrier.
Conformance to standard	EN61131-2:2007

### *Digital Outputs DOUT11 to DOUT14*

Feature	Value
Output high voltage	> X20/05 – 2V
Maximum output current (high level)	160mA per output
Output leakage current (Low output level)	<0.1mA
Overload / short circuit protection	Indefinite. Each output is protected by a self-resetting fuse.
Update rate	1ms
Isolation	DOUT11 to DOUT14 are optically isolated from drive electronics, but not from other 7004-01-00 Digital Inputs / Outputs. Isolation is functional only, intended to eliminate ground loops. It is not a safety isolation barrier.
Conformance to standard	EN61131-2:2007
State at power-up	Off (low)

## Example Applications

*Digital Input to DIN11:*

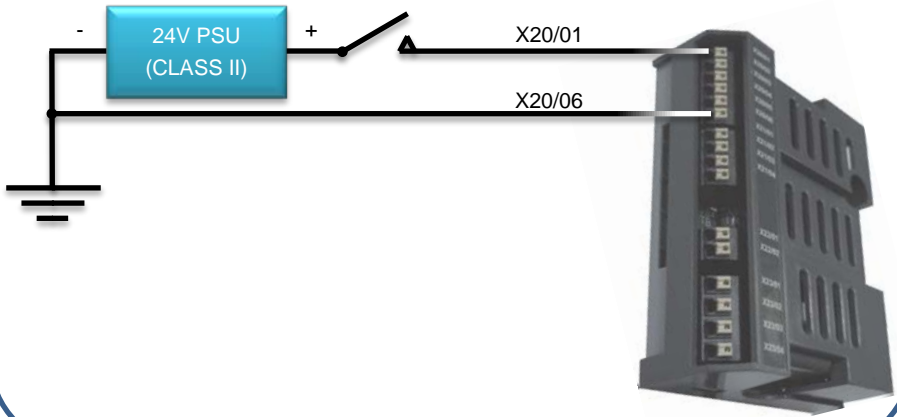

*Digital Output from DOUT11:*

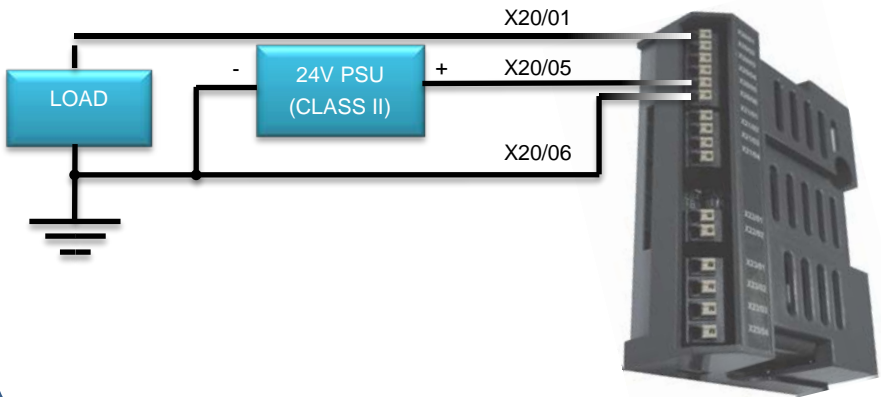

# 12

## Analogue Inputs (7004-01-00 only)

---

The 7004-01-00 offers three identical analogue input ports on terminal X21.

Terminal	Name	Range	Description	
X21	01	AN 0V	0V	Analogue signal reference
	02	ANIN11	-10V to +10V	Analogue input 11 (default = unassigned)
	03	ANIN12	-10V to +10V	Analogue input 12 (default = unassigned)
	04	ANIN13	-10V to +10V	Analogue input 13 (default = unassigned)

Notes:

- These analogue input ports are differential. That means that the signal reference on terminal X21/01 is not directly connected internally to the drive's 0V terminal. It is allowed to float relative to the drive's 0V, within the limits of the common mode voltage range (see specification on page 13). This effectively eliminates ground loops.

Therefore X21/01 must be connected to the user's 0V signal reference which should be grounded at an appropriate point in the system. See the example application on page 14.

- If any analogue inputs ANIN11 to ANIN13 are unused, they should be connected to X21/01 (AN 0V) to prevent invalid values being reported.

## Programming

Parameter	Access	Value	Description
1181	Read only	-100.00% to +100.00%	Value of ANIN11
1182		-100.00% to +100.00%	Value of ANIN12
1183		-100.00% to +100.00%	Value of ANIN13

## Specification

### *Analogue Inputs ANIN11 to ANIN13*

Common mode voltage range	$\pm 10V$ X21/01 relative to drive 0V
Input voltage range	-10V to +10V each analogue input relative to terminal X21/01
Ovrange	>2%
Accuracy	Better than $\pm 1\%$
Absolute maximum input voltage	-20V to +20V relative to terminal X21/01
Input impedance	>50k $\Omega$
Resolution	12 bits + sign
Sample rate	1ms
Conformance to standard	EN61131-2:2007

# 14

## Example Application

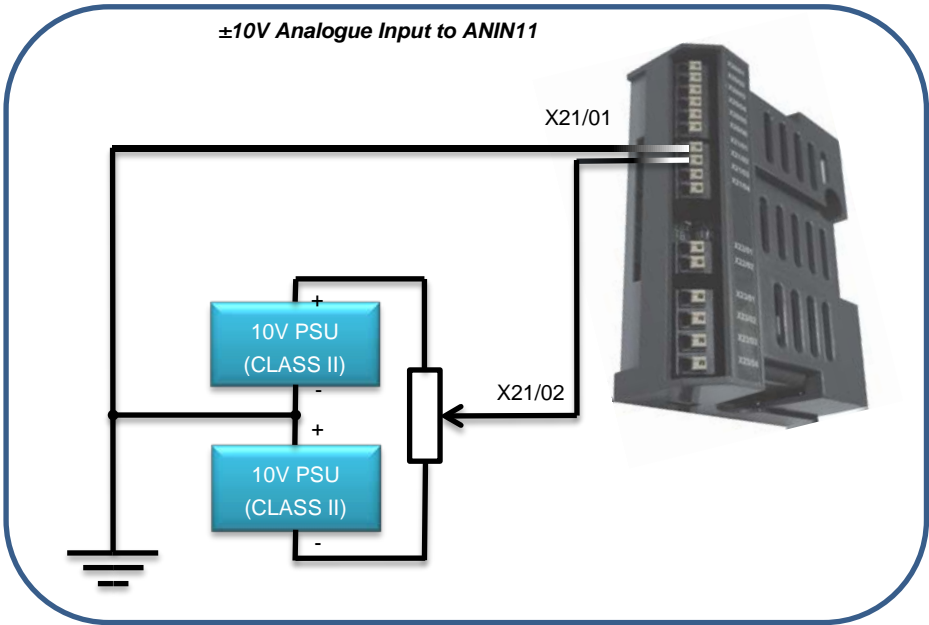

## Motor Thermistor (7004-01-00, 7004-02-00 and 7004-03-00)

The motor thermistor input provides a means of monitoring motor temperature in order to protect the motor from a potentially damaging high temperature.

By default the drive will trip if the motor exceeds a user-defined temperature threshold thereby preventing the motor temperature from rising further.

Terminal		Name	Range	Description
X22	01	TH1	0 to 4.5k $\Omega$	Connect motor thermistor between these two terminals. If thermistor is not required, connect these two terminals together, and ensure PTC thermistor is selected.
	02	TH2		

## Programming

Parameter	Access	Value	Description	
1184	Write or Read	NTC PTC KTY	Thermistor type. Default = PTC	
1004	Write or Read	0 to 4500 $\Omega$	Thermistor trip level. Default = 1000 $\Omega$	
			PTC	Drive trips if thermistor resistance exceeds this trip level.
			NTC	Drive trips if thermistor resistance is less than this trip level.
		KTY	Drive trips if thermistor resistance exceeds this trip level.	
1185	Read only	0 to 4500 $\Omega$	Actual thermistor resistance	

### Specification

Thermistor resistance range	0 to 4.5kΩ
Resistance measurement accuracy	5%
Thermistor compatibility	PTC, NTC, KTY Default = PTC
Measurement supply voltage	1.3V @ 1kΩ
Motor temperature threshold	Resistance threshold set by user. Default = 1kΩ.
Motor temperature reset threshold	Resistance based on temperature threshold. Default = 50% of trip threshold.
Update rate	1 second
Insulation	Reinforced insulation between thermistor terminals and drive electronics.



**Important safety information:**

Insulation and routing of wiring to the GPIO thermistor terminals must be appropriately rated to ensure the correct degree of insulation to other user wiring.

### Example Application

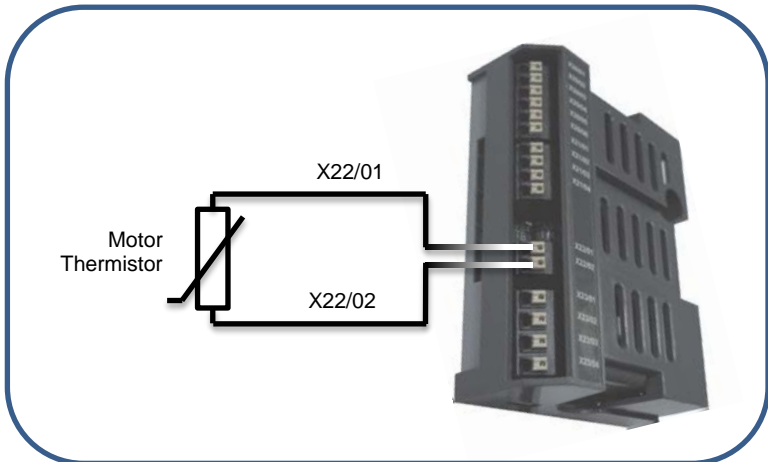



## Volt-free Relays (7004-01-00 only)

The 7004-01-00 option contains two general-purpose relays for use as user outputs.

Terminal	Name	Range	Description
X23	01	RLY11A	Terminal A of relay 11 (default = unassigned)
	02	RLY11B	Terminal B of relay 11 (default = unassigned)
	03	RLY12A	Terminal A of relay 12 (default = unassigned)
	04	RLY12B	Terminal B of relay 12 (default = unassigned)



### Important safety information:

Insulation and routing of wiring to the relay terminals must be appropriately rated to ensure the correct degree of insulation to other user wiring, including the motor thermistor, both inside and outside the drive.

## Programming

Parameter	Access	Bit	Value	Description
00022	Write or Read	0 to 13	x	These bits control other I/O on this board and on the base control board.
		14	0	RLY11 is OFF. Contacts are open.
			1	RLY11 is ON. Contacts are closed.
		15	0	RLY12 is OFF. Contacts are open.
			1	RLY12 is ON. Contacts are closed.

**Specification**

Contact form (each relay)	1 pole normally open
Contact rating	3A @ 250V AC 3A @ 30V DC
Overvoltage category	Category II, TN supply.
Minimum switching capacity	100µA, 100mVDC
Recommended load	Resistive
Contact suppression	None. External components must be added to protect the relay contacts against inductive or capacitive loads.
Expected life	300 x 10 <sup>3</sup> operations (Electrical) 20 x 10 <sup>6</sup> operations (Mechanical)

**Example application**

*Relay Output RLY11 to 230VAC Load:*

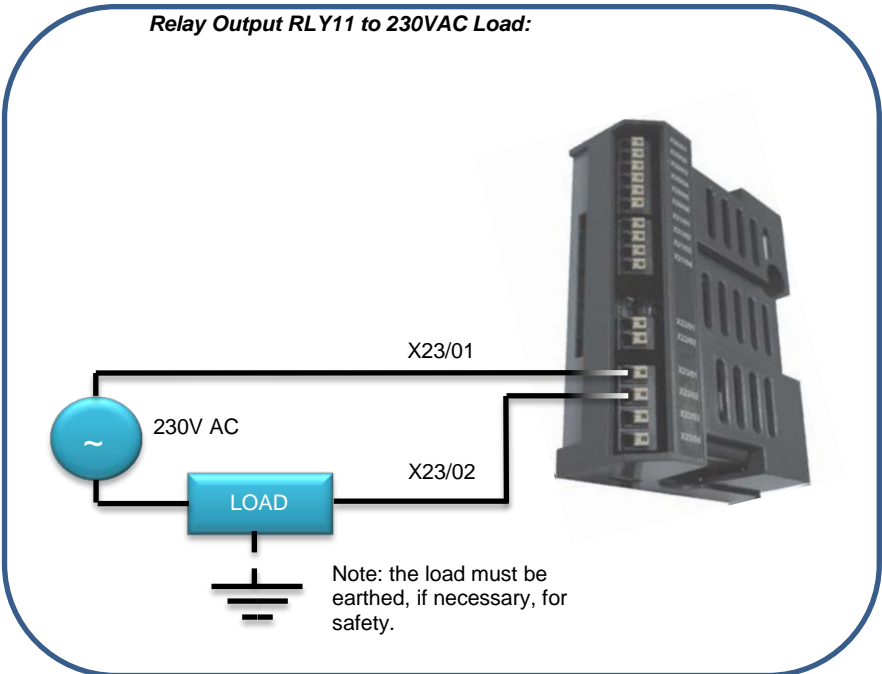

## Real-Time Clock (7004-01-00 and 7004-03-00)

A real-time clock (RTC) is provided in the 7004-01-00 and 7004-03-00 for the user to program the drive to perform functions at specified times.

The RTC is battery-backed, so continues to run when the drive is unpowered. The battery recharges when the drive is powered.

The user can adjust the time and date.

The user can also adjust the RTC rate if it is found to run too fast or too slow over a long period of time. Adjustment is achieved through an RTC trim parameter. A positive value causes the RTC to run faster. A negative value causes the RTC to run slower.

Each increment or decrement in RTC trim value causes the RTC to run faster or slower respectively by 1 part in 1048576, or approximately 1 part per million (ppm). 1ppm is equivalent to approximately 2.5 seconds per month or 31 seconds per year.

### Programming

Parameter	Access	Value	Description
1186	Write or read	See RTC value format.	RTC time and date.
1187	Write or Read	$0 \pm 40$	RTC trim. Allows the user to adjust the RTC clock rate.

### RTC value format

YYYY/MM/DD HH:MM:SS

YYYY = calendar year (Range 1970 to 2106)

MM = calendar month (Range 01 to 12)

DD = day of the month (Range 01 to 31)

HH = hour (Range 0 to 23)

MM = minutes (Range 0 to 59)

SS = seconds (Range 0 to 59)

**Specification**

Time format	See RTC value format above
Initial RTC time on product delivery	Unspecified. User can set time on first power-up
Accuracy (drive powered, RTC trim = 0)	±1 minute / month
Accuracy (drive unpowered, RTC trim = 0)	±5 minutes / month
Battery backup duration. This is the minimum length of time the RTC will continue to run while the drive is unpowered.	6 months
Automatic adjustment for daylight saving	Not supported

## Environmental

---

### **Restriction, Evaluation, Authorisation and Restriction of Chemicals (REACH)**

The Regulation (EC) No 1907/2006 of the European Parliament and of the Council of 18 December 2006 concerning the Registration, Evaluation, Authorization, and Restriction of Chemicals (REACH) entered into force on June 1, 2007. Parker agrees with the purpose of REACH which is to ensure a high level of protection of human health and the environment. Parker is compliant with all applicable requirements of REACH.

The registration requirements do not apply to Parker since it is neither a manufacturer nor an importer of preparations into Europe.

However, product (article) manufacturers or importers into Europe are obligated under Article 33 of REACH to inform recipients of any articles that contain chemicals on the Substances of Very High Concern (SVHC) candidate list above a 0.1% concentration (by weight per article). As of 19<sup>th</sup> December 2011 VSD products manufactured and marketed by Parker do not contain substances on the REACH SVHC candidate list in concentrations greater than 0.1% by weight per article. Parker will continue to monitor the developments of the REACH legislation and will communicate with our customers according to the requirement above.

### **Restriction of Hazardous Substances (RoHS)**

This product is in full compliance with RoHS Directive 2011/65/EU, with respect to the following substances:

- 1) Lead (Pb),
- 2) Mercury (Hg),
- 3) Cadmium (Cd),
- 4) Hexavalent chromium (Cr (VI)),
- 5) Polybrominated biphenyls (PBB),
- 6) Polybrominated diphenyl ethers (PBDE).

## Waste Electrical and Electronic Equipment (WEEE)



Waste Electrical and Electronic Equipment - must not be disposed of with domestic waste.

It must be separately collected according to local legislation and applicable laws.

Product codes 7004-01-00 and 7004-03-00 contain a Nickel-Metal-Hydride (Ni-MH) battery.

Parker Hannifin Company, together with local distributors and in accordance with EU directive 2002/96/EC, undertakes to withdraw and dispose of its products, fully respecting environmental considerations.

For more information about how to recycle your Parker supplied waste equipment, please contact your local Parker Service Centre.

## Packaging

During transport our products are protected by suitable packaging. This is entirely environmentally compatible and should be taken for central disposal as secondary raw material.

# Parker Worldwide

**AE – UAE, Dubai**

Tel: +971 4 8127100  
parker.me@parker.com

**AR – Argentina, Buenos Aires**

Tel: +54 3327 44 4129

**AT – Austria, Wiener Neustadt**

Tel: +43 (0)2622 23501-0  
parker.austria@parker.com

**AT – Eastern Europe, Wiener Neustadt**

Tel: +43 (0)2622 23501 900  
parker.easteurope@parker.com

**AU – Australia, Castle Hill**

Tel: +61 (0)2-9634 7777

**AZ – Azerbaijan, Baku**

Tel: +994 50 2233 458  
parker.azerbaijan@parker.com

**BE/LU – Belgium, Nivelles**

Tel: +32 (0)67 280 900  
parker.belgium@parker.com

**BR – Brazil, Cachoeirinha RS**

Tel: +55 51 3470 9144

**BY – Belarus, Minsk**

Tel: +375 17 209 9399  
parker.belarus@parker.com

**CA – Canada, Milton, Ontario**

Tel: +1 905 693 3000

**CH – Switzerland, Etoy**

Tel: +41 (0)21 821 87 00  
parker.switzerland@parker.com

**CL – Chile, Santiago**

Tel: +56 2 623 1216

**CN – China, Shanghai**

Tel: +86 21 2899 5000

**CZ – Czech Republic, Klecany**

Tel: +420 284 083 111  
parker.czechrepublic@parker.com

**DE – Germany, Kaarst**

Tel: +49 (0)2131 4016 0  
parker.germany@parker.com

**DK – Denmark, Ballerup**

Tel: +45 43 56 04 00  
parker.denmark@parker.com

**ES – Spain, Madrid**

Tel: +34 902 330 001  
parker.spain@parker.com

**FI – Finland, Vantaa**

Tel: +358 (0)20 753 2500  
parker.finland@parker.com

**FR – France, Contamine s/Arve**

Tel: +33 (0)4 50 25 80 25  
parker.france@parker.com

**GR – Greece, Athens**

Tel: +30 210 933 6450  
parker.greece@parker.com

**HK – Hong Kong**

Tel: +852 2428 8008

**HU – Hungary, Budapest**

Tel: +36 1 220 4155  
parker.hungary@parker.com

**IE – Ireland, Dublin**

Tel: +353 (0)1 466 6370  
parker ireland@parker.com

**IN – India, Mumbai**

Tel: +91 22 6513 7081-85

**IT – Italy, Corsico (MI)**

Tel: +39 02 45 19 21  
parker.italy@parker.com

**JP – Japan, Tokyo**

Tel: +81 (0)3 6408 3901

**KR – South Korea, Seoul**

Tel: +82 2 559 0400

**KZ – Kazakhstan, Almaty**

Tel: +7 7272 505 800  
parker.easteurope@parker.com

**MX – Mexico, Apodaca**

Tel: +52 81 8156 6000

**MY – Malaysia, Shah Alam**

Tel: +60 3 7849 0800

**NL – The Netherlands, Oldenzaal**

Tel: +31 (0)541 585 000  
parker.nl@parker.com

**NO – Norway, Asker**

Tel: +47 66 75 34 00  
parker.norway@parker.com

**NZ – New Zealand, Mt Wellington**

Tel: +64 9 574 1744

**PL – Poland, Warsaw**

Tel: +48 (0)22 573 24 00  
parker.poland@parker.com

**PT – Portugal, Leca da Palmeira**

Tel: +351 22 999 7360  
parker.portugal@parker.com

**RO – Romania, Bucharest**

Tel: +40 21 252 1382  
parker.romania@parker.com

**RU – Russia, Moscow**

Tel: +7 495 645-2156  
parker.russia@parker.com

**SE – Sweden, Spånga**

Tel: +46 (0)8 59 79 50 00  
parker.sweden@parker.com

**SG – Singapore**

Tel: +65 6887 6300

**SK – Slovakia, Banská Bystrica**

Tel: +421 484 162 252  
parker.slovakia@parker.com

**SL – Slovenia, Novo Mesto**

Tel: +386 7 337 6650  
parker.slovenia@parker.com

**TH – Thailand, Bangkok**

Tel: +662 717 8140

**TR – Turkey, Istanbul**

Tel: +90 216 4997081  
parker.turkey@parker.com

**TW – Taiwan, Taipei**

Tel: +886 2 2298 8987

**UA – Ukraine, Kiev**

Tel: +380 44 494 2731  
parker.ukraine@parker.com

**UK – United Kingdom, Warwick**

Tel: +44 (0)1926 317 878  
parker.uk@parker.com

**US – USA, Cleveland**

Tel: +1 216 896 3000

**VE – Venezuela, Caracas**

Tel: +58 212 238 5422

**ZA – South Africa, Kempton Park**

Tel: +27 (0)11 961 0700  
parker.southafrica@parker.com

**European Product Information Centre**

**Free phone: 00 800 27 27 5374**

**(from AT, BE, CH, CZ, DE, EE, ES, FI, FR, IE, IL, IS, IT, LU, MT, NL, NO, PT, SE, SK, UK)**

© 2012 Parker Hannifin Corporation. All rights reserved.

**Parker Hannifin Manufacturing Limited,  
Automation Group, SSD Drives Europe,**

New Courtwick Lane, Littlehampton,

West Sussex BN17 7RZ

United Kingdom

Tel: +44(0)1903 737000

Fax: +44(0)1903 737100

www.parker.com/ssd



\* H A 5 0 1 8 3 6 U 0 0 1 0 2 \*