

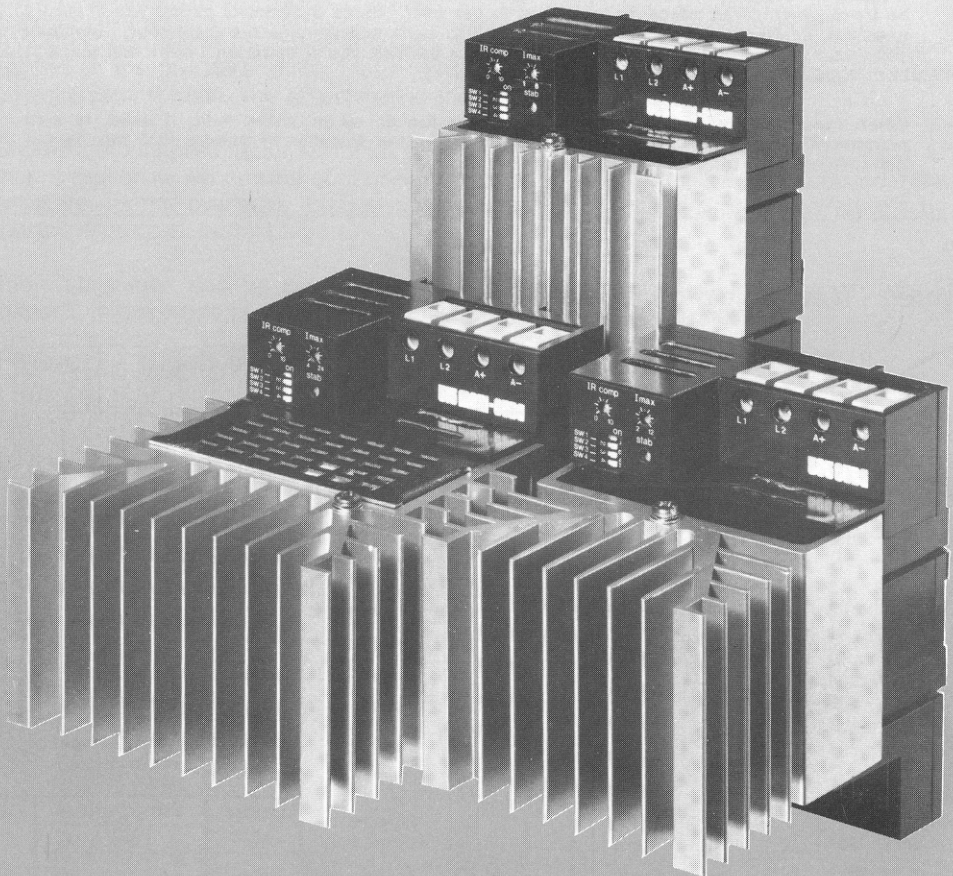

**EUROTHERM  
DRIVES**

# The Cube Family from Eurotherm Drives



**The Complete Family of Small Variable  
Speed DC Drives**

# Controller warranty and service

For further details on Eurotherm Drives controller warranty and repair, refer to the standard conditions of sale as detailed by document IA 058393C.

## WARNINGS

- It is the responsibility of the installer to ensure that the Cube Controller is used as detailed in this manual and that it is safe for operation by the user.
- The Eurotherm Drives Cube Series Controllers are non-isolated products, both the control circuitry and the mains circuitry are at mains potential. Care should be exercised when working on the product to avoid touching bare live parts. External control equipment should be used which gives adequate protection to the user. Since the control circuitry is at mains potential, connecting the signal common (0V) to earth will damage the Controller. Similarly connection of the signal common (0V) to other earthed signal common points will damage both the Cube and the associated equipment.
- When the Cube Series Controller is energised the dc motor shunt field, if used, is also permanently energised. It is the responsibility of the installer to ensure that this is not detrimental to the long term reliability of the dc motor.

Figure1 - Mechanical dimensions and fixings (mm)

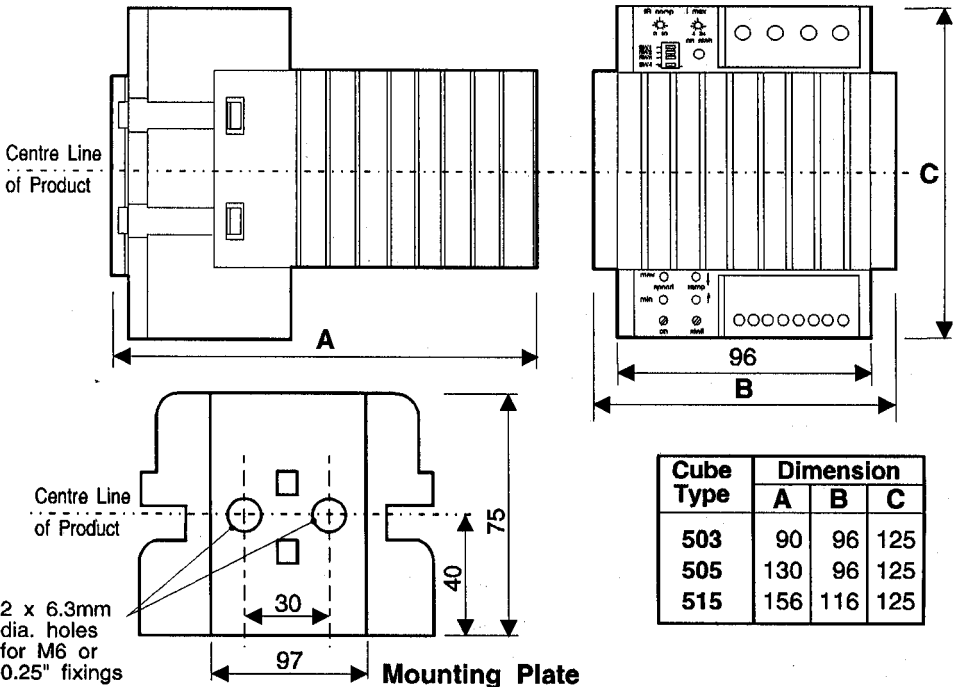

# General description

A 'Cube' is a compact, non-isolated motor speed controller specifically used for dc shunt wound and permanent magnet motors. There are three Cubes currently available, each being capable of controlling motors rated up to:

503 Mini-Cube	1.25hp (0.93kW)
505 Cube	2.5hp (1.86kW)
515 Maxi-Cube	5.0hp (3.72kW)

A Cube controls its associated dc motor by using a linear closed loop feedback signal based on the motor's own dc armature voltage. This enables the Cube to maintain a constant motor speed throughout variable motor loads. An improved speed measurement can be obtained by using a tacho-generator, connected to the motor's shaft, to provide the feedback signal.

A current loop within the speed feedback signal ensures that safe current levels are always applied to the armature of the motor up to the level set by the Cube's maximum current potentiometer ( $I_{max}$ ). This adjustment is linearly calibrated and switchable.

Should the controlled motor stall, (e.g. due to either a faulty field circuit or an excessive load), then a stall timer will remove current from the motor after approximately 15 seconds. Severe armature current overloads, caused by motor induced faults, are protected against by an instantaneous over-current trip.

The Cubes may also be used as linear motor torque controllers by using an adjustable setpoint. In this mode of operation over-speed limiting is a standard feature.

Figure 2 - Block diagram

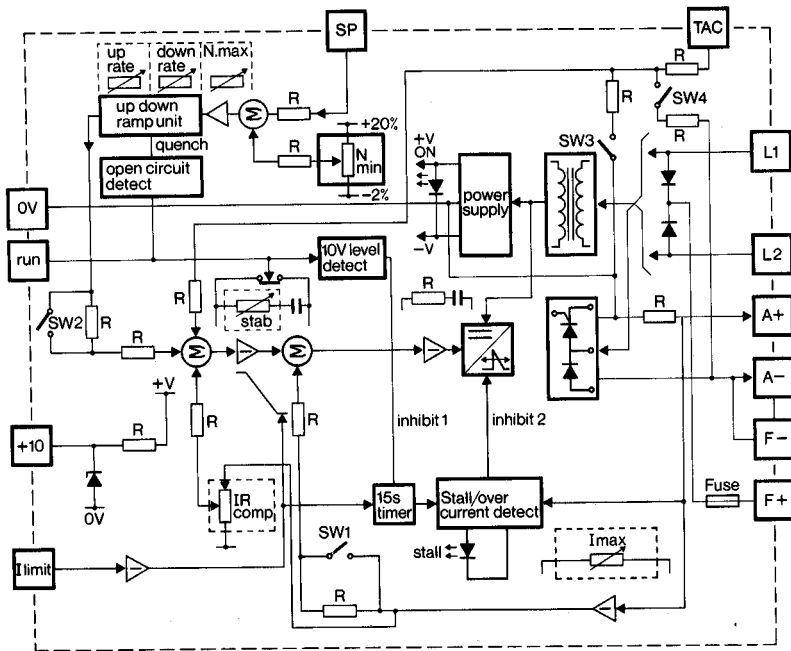

# Notes on wiring

Each member of the *Family of Cubes*, (503, 505 and 515), should be wired according to the basic connection diagram shown in figure 4, with the appropriate variation in wiring for torque control as shown in figure 5.

Ensure that only correctly sized cables are used for connection to the main supply, earth, armature and field circuits (see specification table, inside back cover, for maximum currents). The incoming mains supply should be fused using a high speed semiconductor fuse to protect the wiring from short circuits. This will also provide extra over-current protection for the *Cube*. Eurotherm Drives Ltd. can supply fuse assemblies which can be bulkhead mounted and also act as convenient supply isolators. To order the appropriate fuse assembly, quote the required part number as listed below:

503 Mini: **LA054664U - 10A**    505 Cube: **LA050062U - 20A**    515 Maxi: **LA054173U - 40A**

## Figure 3 - Fuse assembly dimensions

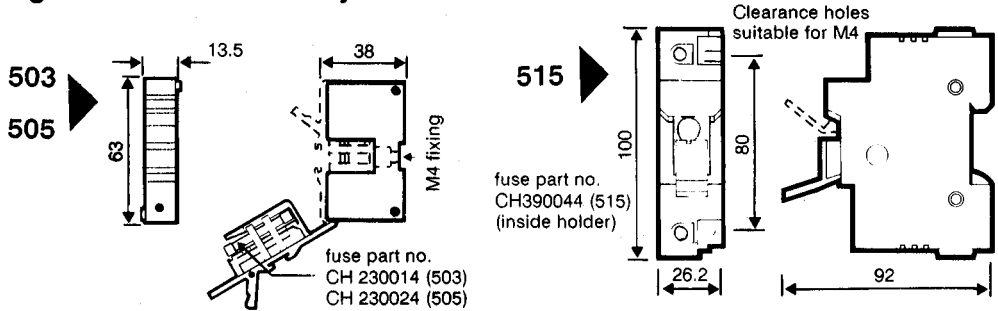

If a tacho-generator (TG) is being used to provide speed feedback signals, then it should be wired as shown by the dotted lines in figure 4. Use screened cable, the screen being attached to earth (the heatsink) at the *Cube* end only. The dc motor speed may be adjusted from zero to full via a 10k single or multi-turn potentiometer.

## Potentiometer reference signals

The speed control potentiometer may be wired using 0.5mm cable if the *Cube* is to be mounted in close proximity.

Should the potentiometer be used for remote speed adjustment where the *Cube* is mounted at a distance in excess of 10 metres, then a screened cable should be used with the braided screen attached to the heatsink earth at the *Cube* end only. Twisted wires may be used for intermediate distances.

## Basic pre-installation checks

Before applying power to the *Cube* for the first time, it is essential to check that the mains supply lies within the correct voltage range as indicated on the rating label of the module. With a correctly rated motor and correct supply, the *Cube* can have power applied and removed with complete safety.

### Note:

It is good practice to apply power the first time with the setpoint set at minimum and the 'run' switch open (see figures 4 & 5). If tacho-generator feedback is being used, it is essential that this practice is followed until the feedback polarity has been correctly established.

# Connection Diagrams

**IMPORTANT**  
*Never connect 0V to either earth or any other low voltage*

**Figure 4 - Basic Speed Controller Connections:**

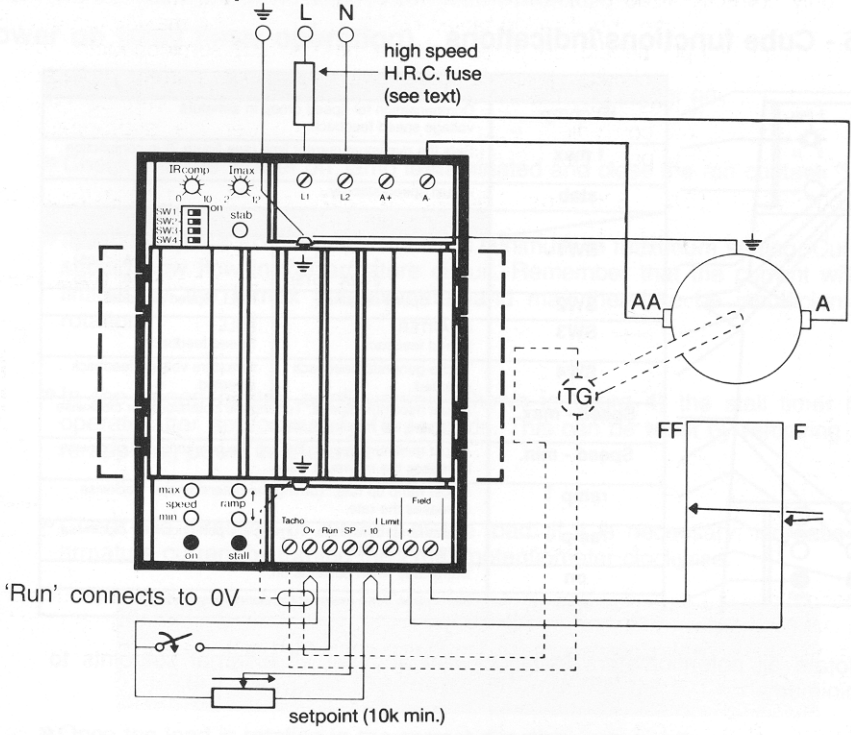

**Figure 5 - Current (Torque) Control Connections:**

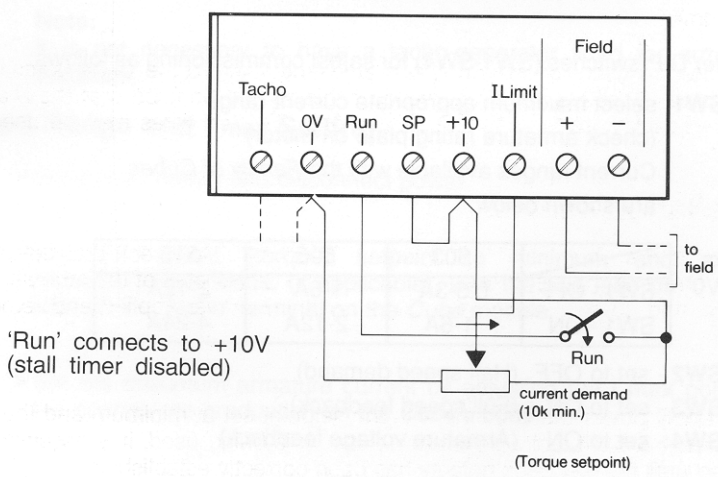

# Installation

**WARNING!**  
Turn the power off first.

## Initial switch selections (power off)

**Figure 6 - Cube functions/indications**

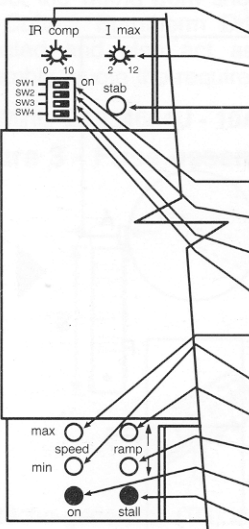

Control	Function	
<b>IR comp</b>	Compensation for speed droop in armature voltage speed feedback.	
<b>I max</b>	Sets the maximum current limit (see figure 7) in conjunction with SW1.	
<b>stab</b>	Adjust speed stability.	
	off	on
<b>SW1</b>	I max    0.5-3A (503) 1-6A (505) 2-12A (515)	I max    1-6A (503) 2-12A (505) 4-24A (515)
<b>SW2</b>	HALF Speed demand.	FULL Speed demand.
<b>SW3</b>	QUARTER Speed feedback.	FULL Speed feedback.
<b>SW4</b>	Tacho-generator feedback selected.	Armature voltage feedback selected.
<b>Speed - max.</b>	Adjust maximum speed. Turning the potentiometer clockwise increases the maximum value.	
<b>Speed - min.</b>	Adjust minimum speed. Turning the potentiometer clockwise increases the minimum value.	
<b>ramp</b> ↑	Adjust ramp up rate. Turning the potentiometer clockwise increases the rate.	
<b>ramp</b> ↓	Adjust ramp down rate. Turning the potentiometer clockwise increases the rate.	
<b>on</b>	Illuminates when power is on.	
<b>stall</b>	Illuminates if the motor stalls during a speed operation.	

- » Rotate all potentiometers anti-clockwise and set all external setpoints to minimum.
- » Set the stability potentiometer midway and open the 'run' contact.
- » Set the power DIP-switches (SW1-SW4) for safest commissioning as follows:

**SW1** select maximum appropriate current range  
(check armature rating plate on motor)  
Current ranges available with the *Family of Cubes*  
are shown below:

**Table 1:**

	503	505	515
SW1 - OFF	0.5-3A	1-6A	2-12A
SW1 - ON	1-6A	2-12A	4-24A

- SW2** - set to OFF (Half speed demand)
- SW3** - set to ON (Full speed feedback)
- SW4** - set to ON (Armature voltage feedback)

- Example
- » Check that the motor and load are safe and free to rotate.
  - » Disconnect tacho-generator connection leads, if any, from the *Cube* and safely connect to an appropriate voltmeter on the  $\pm 200\text{V}$  dc range.

### Power on (stall timer operation)

- » Connect the mains supply to the *Cube* and turn the power on.
- » Check that the 'power on' lamp is illuminated and close the run contact.
- » Increase speed (torque) setpoint from minimum to maximum setting. Current should now flow in the armature circuit. Remember that the current will be limited by the **I max** potentiometer and may therefore be insufficient for rotation.
- » In the speed control configuration (shown in figure 4) the stall timer may operate after approximately 15 seconds. This can be reset by removing and re-applying power to the unit.
- » Check the direction of rotation of the load. If it is necessary, increase the armature current by turning the **I max** potentiometer clockwise.

#### **Warning!**

*Do this with caution, as the maximum current rating of the motor should not be exceeded.*

- » Once the load is rotating in the correct direction, use a voltmeter to check the polarity of the tacho-generator output voltage (if fitted).

#### **Note:**

It is not necessary to have a tacho-generator fitted for armature voltage feedback.

### Speed Range and I max Setting

- » Open 'run' switch and disconnect power.
- » Set the speed (torque) setpoint to minimum and reconnect the tacho-generator leads, (if applicable), with the +ve lead on '0V' and the -ve lead on the 'tacho' terminal on the *Cube* module.
- » Set the maximum armature current by adjusting the **I max** potentiometer to the appropriate graduation on the *Cube's* body.

**Figure 7 - SW1 I<sub>max</sub> selections**

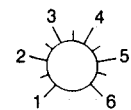
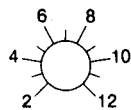
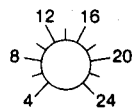
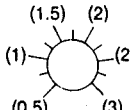
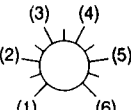
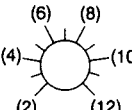
	503	505	515
<b>SW1 on</b>	 <p>I<sub>max</sub> (Amps)</p>	 <p>I<sub>max</sub> (Amps)</p>	 <p>I<sub>max</sub> (Amps)</p>
<b>SW1 off</b>	 <p>I<sub>max</sub> (Amps)</p>	 <p>I<sub>max</sub> (Amps)</p>	 <p>I<sub>max</sub> (Amps)</p>

**Note:**

For torque control applications, an acceptable speed limit is 110%.

» Select either tacho-generator or armature voltage feedback on DIP-switch SW4.

» Use table 2 below to determine the appropriate switch settings for the desired maximum feedback voltage (DIP-switches SW2 and SW3).

**Table 2 - Maximum feedback voltage selection via SW2/SW3:**

Speed selection		Maximum feedback voltage (Speed max. potentiometer)		
SW2	SW3	Min. setting	Mid point	Max. setting
OFF	OFF	15	22.5	30
ON	OFF	30	45	60
OFF	ON	60	90	120
ON	ON	120	180	240

For armature/tacho feedback this will be the maximum voltage at the set speed of the motor.

**Note:**

Do not exceed maximum motor armature voltage ratings.

The motor should now run at approximately the right speed and torque.



## Example

A dc motor has a maximum speed of 1500 rpm with a 180V dc armature. An application for the motor necessitates that its maximum speed be limited to 750 rpm.

1500 rpm = 180V dc armature voltage at 100% of setpoint,  
therefore 750 rpm = 90V dc armature voltage.

From table 2 with the *Cube* **Speed max** potentiometer set at its mid-point position (i.e. 90V), the switch settings should be:

**SW2** - OFF (half speed demand)

**SW3** - ON (full speed feedback)

## Setting Maximum and Minimum Speed Ranges (power on)

When using voltage feedback, speed 'droop' will occur in speed control at higher currents due to the armature resistance losses.

- » Rotate the **IR comp** potentiometer clockwise to remove the speed droop as required. Excessive **IR comp** will cause speed instability.
  
- » Adjust the **ramp** ↑ (up) and **ramp** ↓ (down) speed ramp rates to the required level. Rotating the appropriate potentiometer clockwise will increase the respective ramp rate. Opening the 'run' switch will reset the speed ramps to zero.
  
- » If necessary adjust the stability (**stab**) potentiometer to improve the speed response. Excessive rotation of this potentiometer may cause speed instability. In torque controllers, an extra setpoint can be added to the speed input (SP) to provide external control of the level at which the unit will go into speed operation. If this is not required, link the speed setpoint input to '+10V' as shown in figure 5.

### Warning!

*Continuous operation of the motor at a torque outside the rated speed range will cause the motor to overheat.*

## Factory Presets

The *Cube* may be delivered as part of a motor/gearbox package in which case some of the operating parameters will have been factory set as follows:

<b>Speed max</b>	set as appropriate
<b>I max</b>	set as appropriate
<b>Speed min</b>	set to 5% of maximum speed
<b>Ramp</b> ↑	set slow
<b>Ramp</b> ↓	set slow
<b>Stab</b>	set midway
<b>IR comp</b>	as appropriate

# Fault Finding

Problem	Possible cause	Remedy
CUBE will not power up - no 'on' indication.	Wrong supply voltage.	Check supply range on rating label. It is likely that if too high a voltage has been used, the <i>Cube</i> has been permanently damaged.
	Line fuses blown (if fitted).	Power off, check circuits and replace fuses.
Motor accelerates out of control with tacho-generator feedback and small setpoint.	Tacho polarity.	Power off and reverse tacho connections.
	Tacho linkage.	Check tacho coupling to motor.
	Tacho faulty.	Remove and replace tacho.
Motor rotates in the wrong direction. Speed is controlled though.	Motor connections are wrong for required direction with:	
	1) Armature voltage feedback. 2) Tacho-generator feedback.	Power off and reverse <u>both</u> armature and tacho connections.
Motor will not turn and the stall light comes on after 15 seconds in speed control mode.	Motor shaft locked or jammed.	Power off and check motor and load for stiffness or jamming.
	No field current (not applicable for permanent magnet motors).	Check that dc voltage across field terminals is present. If not, the internal fuse has blown. Otherwise power off and check field circuit for continuity.
	No armature current.	Power off and check armature circuit for continuity.
	Low current limit.	Check current limit with +10V link on <i>Cube</i> .
Motor will not turn.	No run circuit.	Check run contact and wiring.
	No setpoint.	Check connections to and operation of setpoint potentiometer.
Motor will only run at full speed.	Maximum speed setpoint.	Check connections to and operation of setpoint potentiometer.
Motor will not run at correct maximum speed.	Wrong speed range selected on preset switches.	Refer to set-up procedures, page 4.
Stall light comes on after 15 seconds in current control mode.	Incorrect wiring of run contact.	Run contact should be wired between the two terminals marked 'run' and '+10V'.
Stall light comes on immediately after the 'run' contact is closed.	Faulty or incorrect load across the 'A+' and 'A-' terminals.	Check motor armature thoroughly. Cubes should not be used on motors with a low inductance.

# General specifications

Parameter	Symbol	Value	Units
-----------	--------	-------	-------

## Input Supply (see rating label on Cube)

Frequency		50/60±10%	Hz
Voltage	Vs	110/120 ±10% or 220/240 ±10%	V

## Output Ratings

+10V output capability	+10	2 <sup>(4)</sup> (maximum)	mA
Max. dc field current	If	2	A
Rectified field voltage	Vf	0.9 x Vs	V

## Speed Control

Stall detect time		15 minimum 20 typical	s
Type of controller		Variable proportional plus integral	
Feedback method <sup>(1)</sup>		Va                      Tacho	
0-100% load regulation		2 <sup>(2)</sup> (typically)	0.1 (typically)
Max. torque speed range		20:1	100:1 <sup>(5)</sup>
			%

## Current (Torque) Control

Overspeed limiting <sup>(1)</sup>		Standard <sup>(1)</sup>	
Type of controller <sup>(3)</sup>		Fixed proportional plus integral	
Feedback method <sup>(4)</sup>		Non-isolated shunt	
Linearity		2	%

## Adjustment Range

Armature loss comp.	IR comp	0-25% of Va	
Maximum speed <sup>(1)</sup>	N max	±25% <sup>(1)</sup>	
Minimum speed	N min	0-25% of N max	%
Ramp up time	Ramp	1-15 (minimum)	s
Ramp down time	Ramp	1-15 (minimum)	s

## Temperature Ratings

Ambient operating	Ta	0-40	°C
Output derating		-0.04 x Ia above Ta max.	A/°C
+10V temp. coefficient		0.1	%/°C

# Cube specific specifications

Parameter	503 (Mini)	505 (Cube)	515 (Maxi)
-----------	------------	------------	------------

## Output Ratings with typical armature voltage, Va, 80/90V (160/180V)

Max. armature output current <sup>(1)</sup> (Ia, A)	3(3)	6(6)	6(6)	12(12)	12(12)	24(24)
Typical motor horsepower (hp)	0.3(0.6)	0.6(1.25)	0.6(1.25)	1.25(2.5)	1.25(2.5)	2.5(5)
Controller power (kW)	0.25(0.55)	0.55(1.1)	0.55(1.1)	1.1(2.2)	1.1(2.2)	2.2(4.4)
Controller loss (W)	15(15)	20(20)	20(20)	30(30)	30(30)	45(45)
Maximum ac line current (Is, A rms)	6(6)	8.5(8.5)	12(12)	17(17)	24(24)	35(35)
Maximum I <sup>2</sup> t for fusing (A <sup>2</sup> s)	80(80)	80(80)	300(300)	300(300)	800(800)	800(800)
Maximum form factor (Is/Ia)	2(2)	1.4(1.4)	2(2)	1.4(1.4)	2(2)	1.4(1.4)

## Adjustment Ranges

Maximum current <sup>(1)</sup> (I max, A)	0.5-6	1-12	2-24
---	-------	------	------

## Notes:

- (1) Range selected by built in switches.
- (2) With IR comp setting optimised.
- (3) Suitable for armature time constants not less than 5ms.
- (4) All control terminals are at high potential (dc) with respect to earth!
- (5) Consideration must be given to the motor as it may overheat at low speed.

**Eurotherm Drives Ltd., Head Office,**  
New Courtwick Lane,  
LITTLEHAMPTON, West Sussex BN17 7PD.  
Tel. (0903) 721311 Fax. (0903) 723938



**EUROTHERM  
DRIVES**

**Eurotherm Drives Ltd.,**  
4-5 Chetham Court, Winwick Quay,  
Calver Road, WARRINGTON WA2 8RF.  
Tel. (0925) 572111 Fax. (0925) 445567

**Eurotherm Drives Ltd.,**  
Unit No. 59, Stirling Enterprise Park,  
Player Road, STIRLING, Scotland FK7 7RP.  
Tel. (0786) 471674 Fax. (0786) 451095

**Eurotherm Drives Ltd.,**  
Miller House, Corporation Street, RUGBY,  
Warwickshire CV21 2DW.  
Tel. (0788) 562011 Fax. (0788) 550032

**Eurotherm Drives Ltd.,**  
Armstrong House, Armstrong Estate,  
WASHINGTON, Tyne & Wear NE37 1PR.  
Tel. (091) 415 5536 Fax. (091) 415 5538

**Eurotherm Drives Ltd.,**  
Almondsbury Business Centre, Great Park Road,  
ALMONDSBURY, Bristol BS12 4QH.  
Tel. (0454) 616677 Fax. (0454) 615903

---

**Eurotherm Vitesse Variable S.A.,**  
4 Avenue Albert Einstein,  
78190 Trappes, FRANCE.  
Tel. (1)-30503144 Fax. (1)-30661750

**Eurotherm Drives S.p.A.,**  
Via G. Sasso 9, 20030 Lentate Sulsereso,  
Milan, ITALY.  
Tel. 0362-557308 Fax. 0362-557312

**Eurotherm Antriebstechnik GmbH.,**  
Birkenweg 8, D-6146 Alsbach-Haehnlein 1,  
GERMANY.  
Tel. 0625-73005 Fax. 0625-762094

**Eurotherm Drives Inc.,**  
1808 Michael Faraday Court,  
Reston, Virginia, U.S.A.  
Tel. 703-471-4565 Fax. 703-471-0723

ISS.	MODIFICATION	C.P. NO.	DATE	APPROVAL
1	INITIAL ISSUE (HA356404 P)	6229	12/2/91	ARM
2	ERRATA SHEET ADDED	6296	13/5/91	ARM
3	Page 7 reference to figure 4 should read figure 5	7649	29/10/92	ARM
4	updated Telephone/Fax Numbers on area offices.	8551	7.9.93	ARM
5	"WARNING" STATEMENTS ADDED TO INDEX COVER of MANUAL	9579	20/6/99	GDL

FIRST USED ON

MODIFICATION RECORD

CUBE MANUAL



LITTLEHAMPTON  
ENGLAND  
TELEX 87142



DRAWING NUMBER

ZZ 356404 C

SHT. 1

OF 1