



Power factor regulators

computer MAX 6 / computer MAX 12



INSTRUCTION MANUAL

(M98228201-03-17A)



SAFETY PRECAUTIONS

Follow the warnings described in this manual with the symbols shown below.

	<p>DANGER Warns of a risk, which could result in personal injury or material damage.</p>
---	---

	<p>ATTENTION Indicates that special attention should be paid to a specific point.</p>
---	--

If you must handle the unit for its installation, start-up or maintenance, the following should be taken into consideration:

	<p>Incorrect handling or installation of the unit may result in injury to personnel as well as damage to the unit. In particular, handling with voltages applied may result in electric shock, which may cause death or serious injury to personnel. Defective installation or maintenance may also lead to the risk of fire. Read the manual carefully prior to connecting the unit. Follow all installation and maintenance instructions throughout the unit's working life. Pay special attention to the installation standards of the National Electrical Code.</p>
---	---

	<p>Refer to the instruction manual before using the unit In this manual, if the instructions marked with this symbol are not respected or carried out correctly, it can result in injury or damage to the unit and /or installations.</p>
---	--

CIRCUTOR, SA reserves the right to modify features or the product manual without prior notification.

DISCLAIMER

CIRCUTOR, SA reserves the right to make modifications to the device or the unit specifications set out in this instruction manual without prior notice.

CIRCUTOR, SA on its web site, supplies its customers with the latest versions of the device specifications and the most updated manuals.

www.circutor.com



	<p>CIRCUTOR, recommends using the original cables and accessories that are supplied with the device.</p>
---	---

CONTENTS

SAFETY PRECAUTIONS	3
DISCLAIMER	3
CONTENTS	4
REVISION LOG.....	5
SYMBOLS.....	5
1.- VERIFICATION UPON RECEPTION.....	6
2.- INTRODUCTION AND SAFETY RECOMMENDATIONS.....	7
2.1.- SAFETY	7
2.2.- STARTING SCREEN	8
2.3.- DEFINITIONS	8
2.3.1.- FOUR QUADRANT REGULATORS.....	8
2.3.2.- FCP PROGRAM (FAST COMPUTERIZED PROGRAM).....	8
2.3.3.- STAGES AND STEPS	8
2.3.4.- STAGES RATIO PROGRAM.....	8
2.3.5.- PLUG & PLAY	9
3.- PRODUCT DESCRIPTION	10
4.- DEVICE INSTALLATION	11
4.1.- MECHANICAL INSTALLATION	11
4.2.- CONNECTIONS.....	11
4.3.- CABLING CROSS SECTIONS AND PROTECTIONS	12
4.4.- SCHEMATICS.....	13
4.4.1.- COMPUTER MAX 6.....	13
4.4.2.- COMPUTER MAX 12.....	13
5.- OPERATION	15
5.1.- DISPLAY SCREEN	15
5.2.- MEASURED PARAMETERS.....	16
5.3.- ERRORS AND ERROR MESSAGES.....	16
5.4.- ALARM RELAY.....	16
5.5.- REGULATOR STATUS AND KEY FUNCTIONS.....	17
5.5.1.- KEY FUNCTIONS IN NORMAL RUN STATUS.....	17
5.5.2.- KEY FUNCTIONS IN SET-UP STATUS	17
6.- CONFIGURATION	19
6.1.- CONFIGURABLE PARAMETERS	19
6.1.1.- PLUG&PLAY FUNCTION.....	19
6.1.2.- COS Φ TARGET	20
6.1.3.- SMALLER AVAILABLE CAPACITOR STEP	20
6.1.4.- C/K PARAMETER CALCULATION.....	21
6.1.5.- STAGE'S CONFIGURATION OF PF CORRECTION EQUIPMENT (CONFIGURATION PROGRAM)	21
6.1.6.- CONNECTION AND RE-CONNECTION TIME SETTINGS	22
6.1.7.- SELECTION OF THE NUMBER OF STAGES	22
6.1.8.- U, I PHASE ANGLE SETTING.	22
6.1.9.- PROGRAMMING THE CT RATED CURRENT (PRIMARY).	23
6.2.- SET-UP MENU AND PROCEDURE	23
6.2.1.-HOW TO ACCESS THE SET-UP MENU	23
6.2.2.-NAVIGATION SCHEMATIC	24
7.- RUN STATUS.....	25
7.1.- FUNCTIONS OF THE DEVICE IN NORMAL RUN MODE.....	25
7.2.- COMPUTER MAX BEHAVIOUR IN ALARM MODE	26
8.- TECHNICAL FEATURES	27
9.- MAINTENANCE AND TECHNICAL SERVICE.....	29
10.- GUARANTEE.....	29
11.- CE CERTIFICATE	30





REVISION LOG

Table 1: Revision log.

Date	Revision	Description
11/17	M98228201-01-17A	New manual desing

SYMBOLS

Table 2: Symbols.

Symbol	Description
	In compliance with the relevant European directive.
	Safety category of the device : Class II
	Device covered by European directive 2012/19/EC. At the end of its useful life, do not leave the unit in a household waste container. Follow local regulations on electronic equipment recycling.
	DC current
	AC current

Note: The images of the devices are for illustrative purposes only and may differ from the original device.

1.- VERIFICATION UPON RECEPTION

Check the following points when you receive the device:

- a) The device meets the specifications described in your order, (See label at the rear face, **Figure 1**)

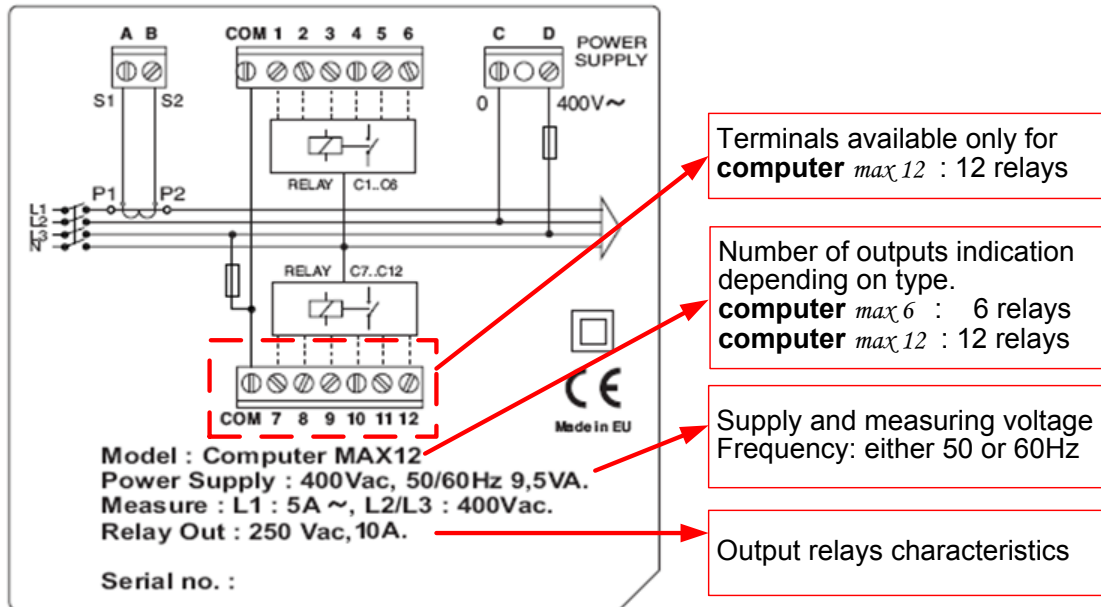



Figure 1: Rear face label.

- b) The device has not suffered any damage during transport.
- c) Perform an external visual inspection of the device prior to switching it on.
- d) Check that the characteristics in the label are suitable for the site where the regulator has to be installed. (Supply voltage and frequency, measuring range, etc.)
- e) Check that it has been delivered with the following:
 - An installation guide.

	<p>If any problem is noticed upon reception, immediately contact the transport company and/or CIRCUTOR's after-sales service.</p>
---	--

2.- INTRODUCTION AND SAFETY RECOMMENDATIONS

CIRCUTOR would like to thank you for showing your trust by choosing one of our **computer MAX** series regulators. These devices are constructed with the latest state-of-the-art technology, including a powerful processor to calculate the optimum algorithms for achieving the best compensation of $\cos\phi$.

The devices comply with the Electrical Safety Standard EN 61010, in accordance with the requirements of the Low Voltage Directive (LVD) 73/23/EC and EMC Directive (2004/108/EC) and, therefore, they are certified to carry the CE mark.



This user manual describes the operation of the **computer MAX** series regulators and shows the user the procedures required to install, commission and operate the devices.

2.1.- SAFETY

	<p>The installation and maintenance of the device must be performed by duly trained and authorised staff and in accordance with the national and international standards. Any inappropriate manipulation or use of this equipment out of the conditions specified by the manufacturer may involve serious dangers to the user.</p> <p>Before performing any maintenance operation on the computer and associated PF compensation equipment, be sure to disconnect the main switch. After disconnecting the switch, wait at least 5 minutes to ensure that the capacitors are totally discharged.</p>
--	---

During the installation, maintenance or commissioning of equipment regulated by a **computer MAX** device, the following safety precautions must be observed:

- ✓ Before connecting the equipment make sure that the earth terminals have been properly connected. A defective earth connection may cause a wrong operation of equipment and involves a danger of electric shock to the user or system operator.
- ✓ Maintenance must be performed taking the necessary precautions to avoid electrocution and electric shock. Ensure that the device has been disconnected and wait the necessary time to ensure that the capacitors are totally discharged before any maintenance action. We recommend the use of safety goggles and gloves when cabinet doors are open and protection covers removed.
- ✓ If a PF compensation device is connected to mains and capacitors are accidentally connected without load, a resonance may occur. In such condition voltage harmonics may be amplified, cause overvoltage and damage the compensation device and other equipment connected to the mains
- ✓ The start-up and interruption procedures indicated in the manual must be followed to avoid damaging the PF equipment and/or other equipment connected to mains.
- ✓ The adjustment or replacement of components or parts of the device must be made with original replacement parts and in accordance with the procedures described in the corresponding instruction manual.

2.2.- STARTING SCREEN



When the **computer MAX** is started (just after supply connection) the screen shows a code indicating the device version. It's important to indicate this code in case of reporting any device fault or error.

2.3.- DEFINITIONS

In this section we shall give several definitions which will be useful to understand several sections of this manual.

2.3.1.- FOUR QUADRANT REGULATORS

This term is used to describe the regulators which are able to perform measure and control, either if the active power flows from the utility to the customer network (the common case of a consuming facility) or if it flows in the reverse sense. The later is the case of facilities containing power generation equipment which export some amount of generated power to the utility.

2.3.2.- FCP PROGRAM (FAST COMPUTERIZED PROGRAM)

The devices having FCP program, control the switching of capacitor stages in order to minimize the number of switching operations to reach the required PF compensation. Moreover, the program assigns the capacitor stages to be connected or disconnected using a FIFO criterion (FIFO= First IN, first OUT), that way the times of use of all stages are equalized.

2.3.3.- STAGES AND STEPS

We must distinguish between these two terms.

In this manual we call stage to each of the capacitor groups that constitute the PF correction device. The capacitor **stages** in PF correction equipment may have all the same power or not, as explained in the following paragraphs.

The term **step** is used to describe the minimum fraction of reactive power in which the PF correction equipment is divided. Usually this is the power of the lower stage.

2.3.4.- STAGES RATIO PROGRAM

Powers of successive capacitor stages in PF correction equipment generally follow certain patterns called stages ratio program or simply "**Program**". The stages program indicates the relationship between the different capacitor stage powers. Most common stages ratio programs are the as follows:

Program 1:1:1 . All capacitor stages have the same rated power (kvar). For instance, a 5-stage device of 100 kvar would be formed by 5 equal stages of 20 kvar and would be described as a device of (5 x 20) kvar.

Program 1:2:2 . All capacitor stages from the second and up have a rated power (kvar) which is twice the rated power of first stage. For instance, a 5-stage device of 180 kvar would be formed by a first stage of 20 kvar and 4 equal stages of 40 kvar, and would be described as a device of (20 + 4 x 40) kvar.

Program 1:2:4 . The rated power of the second stage is twice the rated power of the first stage and the rated power of third stage and up is 4 times the power of the first stage. For instance, a 5-stage device of 300 kvar would be formed by a first stage of 20 kvar, a second stage of 40 kvar and 3 equal stages of 80 kvar, and would be described as a device of $(20 + 40 + 3 \times 80)$ kvar.

Other switching programs. Other switching programs are also commonly available, like 1:2:2:4 or 1:1:2:2, etc. Abbreviated designation form, as can be deduced from previous cases, consists of a sequence of numbers giving the relationship between the different stage powers (kvar), and the first stage power, which value is taken as device (1). The successive stages will be designated by 1, or 2 or 4, etc. meaning that the kvar ratio of such stages with regard to first stage are equal, twice, four times, etc.

2.3.5.- PLUG & PLAY

When a reactive energy regulator is installed, a series of parameters must be configured for its correct operation. Some of these parameters might be hard to know, such as, for example, the voltage phases or the voltage corresponding to the current measured, as well as the current transformer ratio.

The **computer MAX** features a smart automatic process that detects the necessary parameters, such as:

- ✓ **C/K**: calculates the ratio between the current transformer and the power of the smallest step.
- ✓ **Phase**: identifies the phase sequence between voltages and the correspondence with the connected current.

3.- PRODUCT DESCRIPTION

The power factor regulators, of types **computer MAX 6** and **MAX 12** measure the $\cos \varphi$ (sometimes called Displacement Power Factor, DPF) in a supply network and control the connection and disconnection of power capacitors in order to regulate such parameter.

The difference between the two types is the number of output relays, which determines the number of stages that they can control.



Table 3:Models.

Model	Maximum Nr of output relays
computer MAX 6	6 relay outputs
computer MAX 12	12 relay outputs

Among the most important features of this PF regulator series we can stand out the following:

- **FCP regulation system**, which minimizes the number of switching operations.
- Wide choice of switching **programs**: 1:1:1, 1:2:2, 1:2:4 , 1:1:2:2, etc. which allows the split up of the total power into up to 31 steps in **MAX 6** or up to 79 steps in **MAX 12**.
- **Four quadrants control** (see **Figure 2**), display of the connected stages, of $\cos \varphi$ and active and reactive power signs (inductive \sim or capacitive \cap).
- **LCD display** screen with three segments characters plus 20 icons to sign up the different possible working conditions.
- Regulator set-up with only three keys and without disconnecting the device from the supply.
- Multiple supply frequency range, either 50 or 60 Hz
- Main electrical parameters displayed during RUN mode
- Easy panel mounting, without the need of tools.
- Front frame size (144 x 144 mm) according to DIN 43 700 (panel hole 138⁺¹ x 138⁺¹ mm)
- Measurement and power supply in one single input.
- Four quadrant regulation (suitable for installations importing or exporting energy)

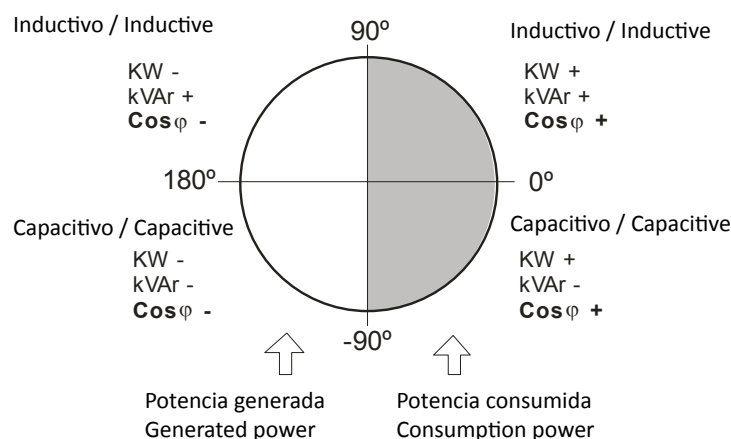



Figure 2:Power signs in four quadrants measurements

4.- DEVICE INSTALLATION

This section contains information instructions and warnings that the user must follow by its own security and to ensure safe operation of the device.

	<p>computer MAX regulators are usually connected to equipment containing capacitors, which remain charged after removing supply voltage. To avoid risk of electric shock, you must wait at least 5 minutes between the disconnection of the equipment and handling of the internal components thereof.</p> <p>Any handling or use of equipment in different way or conditions to that specified by the manufacturer, may compromise the user safety.</p>
---	---

In case that some damage or deterioration signs are detected in the device or a wrong operation is observed, disconnect the supply voltage and contact **CIRCUTOR** authorized technical service.

To safely use the **computer MAX 6** and **computer MAX 12** it is important that people installing it or handling it follow the usual safety precautions stated in the LV or MV Electrical Code Rules of each Country as well as the different warnings stated in this instruction manual.

4.1.- MECHANICAL INSTALLATION

Mechanically, the device is intended to be mounted attached to the front door of the cabinet. The fitting hole must be according to DIN 43 700, (dimensions 138⁺¹x138⁺¹mm).

4.2.- CONNECTIONS

Before connecting the supply to the device check the following items:

	<p>The installation and maintenance of the device must be carried out by specialised and dully trained staff, according to National Electric Codes and Rules and International Standards.</p> <p>All the connections must be at the inner part of a protection cabinet.</p> <p>Notice that when the device is connected to supply, the voltage at certain terminals can be hazardous and cause electric shock in case of contact. Opening the electrical cabinet or removing certain covers can compromise the user safety and should only be done by qualified and authorized staff.</p> <p>The computer MAX devices are used together with capacitor banks, which can remain charged after supply disconnection. In order to avoid shock hazard, wait during 5 minutes after supply disconnection before any manipulation inside the equipment cabinet.</p>
---	--

computer MAX devices require current sensing of the installation. A current transformer (CT) must be installed externally to perform this function. Usually the current ratio of the CT is $I_n / 5 A$, where I_n must be at least 1,5 times the Maximum expected load current.

The CT must be installed at the incoming supply line (point of coupling of the user), so that

it measures the total current of all the loads, including also the compensation capacitor bank (see **Figure 3**)

The CT should be installed preferably in phase L1, while the voltage measuring terminals of Computer MAX should be connected to phases L2 and L3 (see schematics in **Figure 4** and **Figure 5**). It's important to respect the connection senses of P1-P2 and S1-S2 shown in the above mentioned figs, otherwise the phase difference will have to be corrected by adjusting the device according to set-up procedure indicated in **"6.1.8.- U, I PHASE ANGLE SETTING."**

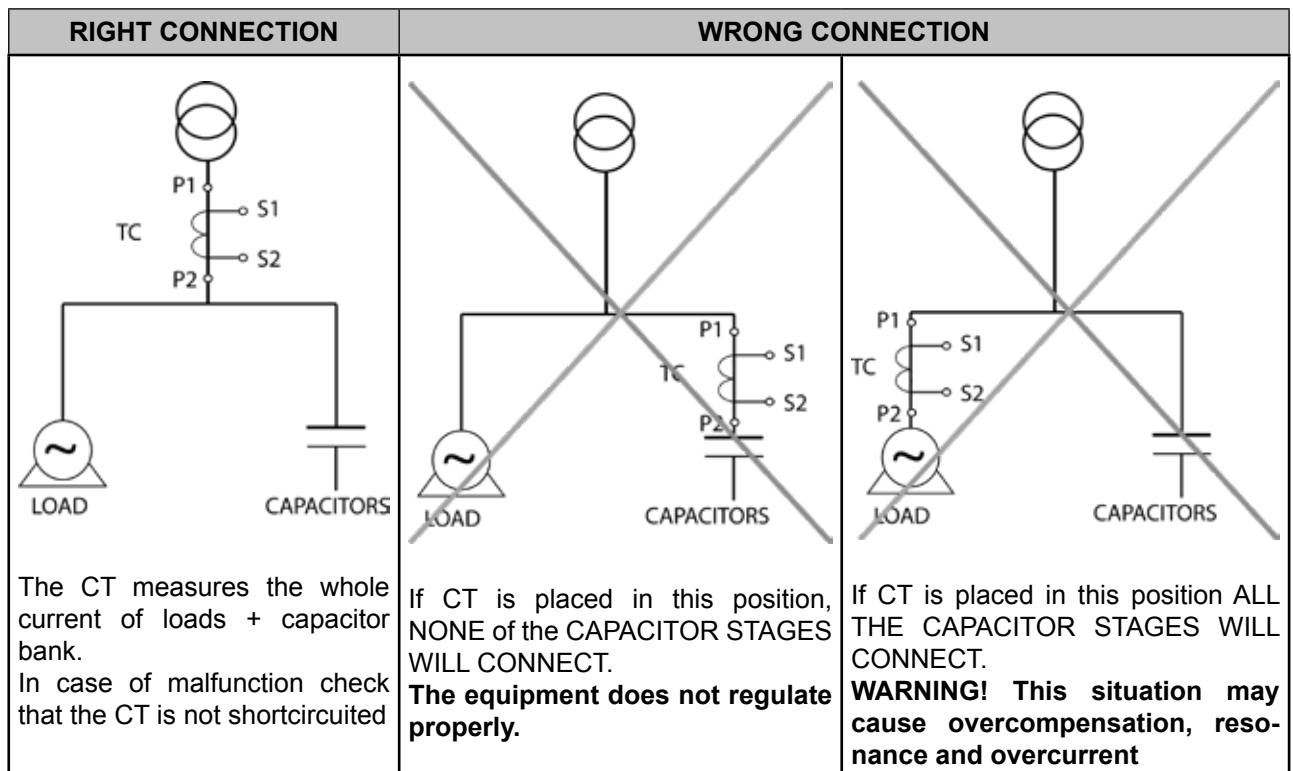

Figure 3: Placement of current transformer (CT)

4.3.- CABLING CROSS SECTIONS AND PROTECTIONS

The supply circuit must be protected by means of fuses or a circuit breaker sized between 0,5 and 2 A.

Recommended fuses are gl type (IEC 269) or M type (IEC 127). A main circuit breaker must be provided in order to allow the disconnection of control circuits from supply (Computer, relays, contactor coils, etc.)

The main switch must be easily accessible. The cabling cross section must be minimum 1,5 mm² for the voltage supply and for the relay outputs and 2,5 mm² for the cables connecting secondary of CT to **computer MAX**. For distances between CT and computer higher than 10m the cross section of the last must be increased at a rate of 1 extra mm² every 10 m.

4.4.- SCHEMATICS

4.4.1.- COMPUTER MAX 6

Table 4: Computer MAX 6 terminals.

Nr	Description	Nr	Description
A	Current input S1	4	Relay Output 4
B	Current input S2	5	Relay Output 5
COM	Relays common	6	Relay Output 6
1	Relay Output 1	C	Supply/Measure input 0 V
2	Relay Output 2	D	Supply/Measure input ⁽¹⁾
3	Relay Output 3		

⁽¹⁾ Rated voltage depending on type. See device label

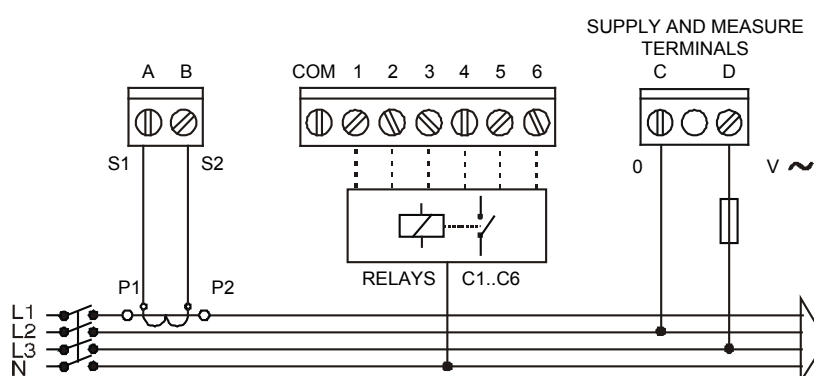

Figure 4: Computer MAX 6.

4.4.2.- COMPUTER MAX 12

Table 5: Computer MAX 12 terminals.

Nr	Description	Nr	Description
A	Current input S1	7	Relay Output 7
B	Current input S2	8	Relay Output 8
COM	Relays common	9	Relay Output 9
1	Relay Output 1	10	Relay Output 10
2	Relay Output 2	11	Relay Output 11
3	Relay Output 3	12	Relay Output 12
4	Relay Output 4	C	Supply/Measure input 0 V
5	Relay Output 5	D	Supply/Measure input ⁽¹⁾
6	Relay Output 6		

⁽¹⁾ Rated voltage depending on type. See device label

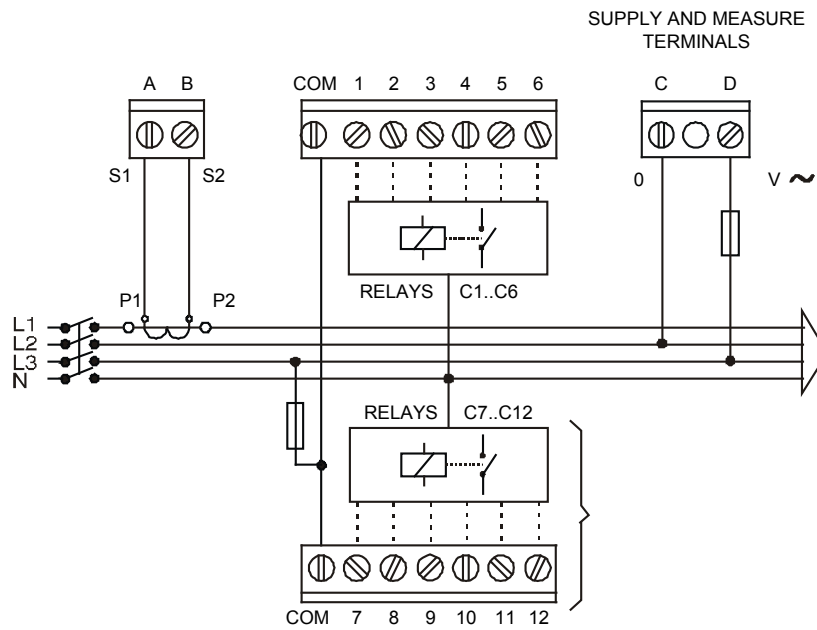

Figure 5: Computer MAX 12.

Note: For computer MAX 12 devices (12 relay outputs) the connection between COM terminals in the upper and lower terminal strips must be done externally.

5.- OPERATION

The PF regulator's front panel shows the following items:

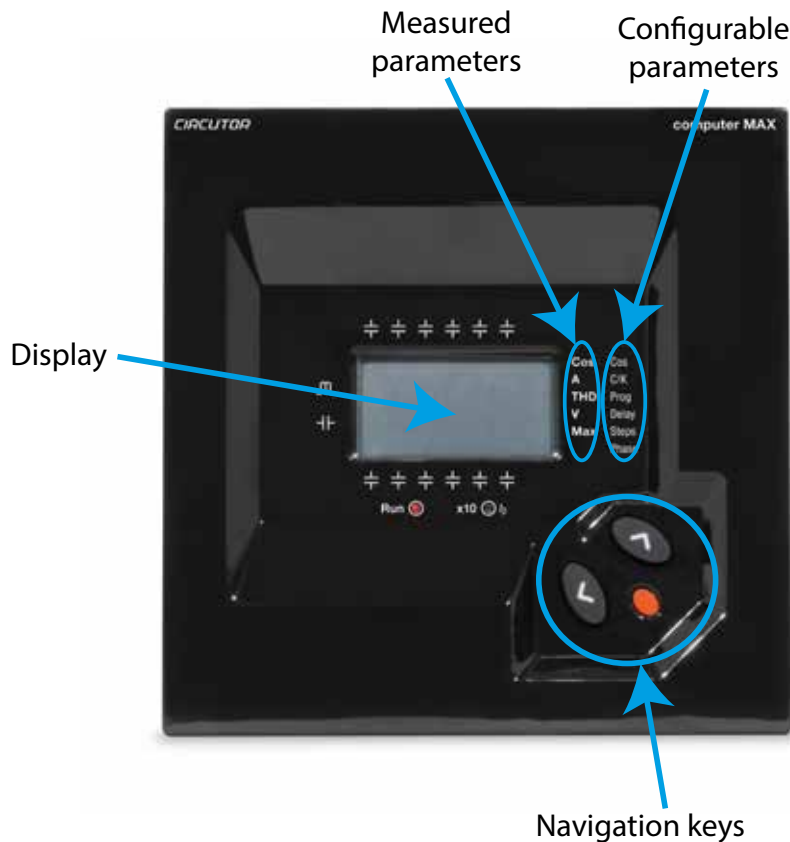

Figure 6: computer MAX description.

5.1.- DISPLAY SCREEN

computer MAX devices are equipped with a 3 digits x 7 segments LCD screen. The screen has also a set of icons, which provide information about the regulator status. The main indications are: $\cos\phi$ value, reactive power sign (\sim for lagging or inductive PF and + for leading or capacitive PF), connected stages and measurement of different parameters (see “5.2.- MEASURED PARAMETERS”)

Table 6: Display screen.

Icons	Screen and LEDs	Icons indications
<p>\sim Lagging or inductive power indication</p> <p>+ Leading or capacitive power indication</p> <p>The Run LED (red) is ON in normal working conditions</p> <p>The x10 LED shows that the reading of current or MAX. current has to be multiplied by 10</p>		<p>In normal working conditions, RUN LED (red) is ON and \blacktriangleright cursor points to the parameter being displayed (Left column list)</p> <p>In SET-UP mode, the RUN LED is OFF, the \blacktriangleright cursor is blinking and pointing to the parameter being configured (Right column list).</p> <p>Symbols indicating the stages which are connected (only in RUN mode)</p>

5.2.- MEASURED PARAMETERS

When the device is in normal RUN mode, the following parameters can be displayed: **cosφ**, **mains current**, **THD of both mains current and mains voltage**.

The device can also display the maximum values of mains current and voltage since the last parameters clear.

The parameter being displayed can be selected with the navigation keys and is indicated by the ► cursor.

5.3.- ERRORS AND ERROR MESSAGES

In case that the regulator detects a possible error, the front screen shows an error code. The possible error codes are listed and explained in **Table 7**.

Table 7: Possible errors and messages displayed on the screen

Error message	Description
E01	Load current below the threshold current, or current transformer (CT) not connected. Appears if $I_{sec} < 0,05$ A
E02	Overcompensation. The regulator detects that some stages should be disconnected but all the stages are already disconnected.
E03	Under-compensation. The regulator detects that some stages should be connected and all the stages are already connected.
E04	Overcurrent. The measured current exceeds the rated current by a +20%. (Rated current is considered to be the CT primary rated current)
E05	Overvoltage. The measured voltage exceeds the rated voltage by a +15%.

5.4.- ALARM RELAY

In case that the number of stages configured in a **computer MAX 6** or **MAX 12**, is less than 6 or 12 respectively, the relay number 6 or 12 is automatically configured as alarm relay.

The relay remains connected in absence of alarm (positive safety) and disconnects in case that one or more of the errors listed in section “**5.3.- ERRORS AND ERROR MESSAGES**” occur. Notice that the absence of supply voltage will always be detected as an alarm condition

The alarm relay has a delay of 10 s in case of **Over-compensation** and **Under-compensation**, but the operation is instantaneous (delay < 1 s) in case of **Over-voltage** and **Over-current**.

5.5.- REGULATOR STATUS AND KEY FUNCTIONS

computer MAX regulators have two possible status.

✓**Normal or RUN Status:** This is the normal working status of the regulator. In such status the device measures and displays the $\cos \phi$ of the loads and automatically regulates the connection and disconnection of capacitors in order to compensate according to programmed target value. The regulation depends on several parameters configured during the starting set-up process.



✓**Set-up or adjustment status:** This status allows the configuration of the device. Push the key  for a time >1 s to enter the set-up status mode. This will stop the automatic PF regulation, will cause the progressive disconnection of connected stages and once disconnected will allow the set-up of the regulator.



The navigation keys have different functions depending on the regulator status.

5.5.1.- KEY FUNCTIONS IN NORMAL RUN STATUS

Table 8: Key functions in normal run status.

Key	Function
	Key to enter set-up mode: After a long push (> 1 s) of this key, the device will enter the set-up mode, and will accept configuration changes.
	Manual connection of capacitor stages: If this key is pushed for more than 1s, the regulator starts connecting new steps in a sequential mode, respecting the adjusted connection times t_{on} .
	Manual disconnection of capacitor stages: If this key is pushed for more than 1s, the regulator starts disconnecting steps in a sequential mode, respecting the adjusted disconnection times, t_{off} .

5.5.2.- KEY FUNCTIONS IN SET-UP STATUS

Table 9:Key functions in set-up status







Key	Function
	<p>Long Push (>1 s): This is to initiate or exit the set-up mode. Exiting the set-up mode with a long push (>1 s) will automatically save the changed parameters. Exiting with a short push will not save the changes.</p> <p>Long Push (<1 s): This is used to initiate or exit the different set-up sub-menu options (different configurable parameters). Warning! The new programmed values are not saved unless a long push of this key (>1 s) is used to exit the set-up menu.</p> <p>Start Plug&Play process</p>
	<p>Upwards navigation in the menu options available in the set-up menu.</p> <p>Increment of numerical values inside the set-up sub-menus.</p>

Tabla 9 (Continuation): Key functions in set-up status.

key	Function
	Downwards navigation in the menu options available in the set-up menu. Decrement of numerical values inside the set-up sub-menus. Change the digit to be edited in case of numerical values with more than one digit.
 long push	Alarm Enable / Disable: keep pushing these keys at the same time for more than 1s to disable  or enable  Measured current below threshold, Over-compensation and Sub-compensation alarms (“5.3.- ERRORS AND ERROR MESSAGES”). When these alarms were disabled, the regulator doesn't show its error messages.
 long	Stop Plug&Play process.

6.- CONFIGURATION

6.1.- CONFIGURABLE PARAMETERS



In order to adapt the regulator to the loads, certain parameters of the Computer MAX must be set-up. The programmable parameters, the required settings and the set-up procedure are explained here below. See also paragraph **“5.5.2.- KEY FUNCTIONS IN SET-UP STATUS”** to see how to select the different menu options.

The configurable parameters are listed and shortly explained below.

6.1.1.- PLUG&PLAY FUNCTION

To access the Plug&Play screen, press the   buttons to open the following screen:



Press  to start the process; if you want to stop the process, long , and it will return to its initial state.

Once started, the digits will start flashing and the device will start a capacitor measurement, calculation and connection and disconnection process to gather the following capacitor bank parameters: **Phase** (**“6.1.8.- U, I PHASE ANGLE SETTING.”**) y **C/K Factor** (**“6.1.3.- SMALLER AVAILABLE CAPACITOR STEP”**).

Once the device's Plug&Play process has finished and no error has occurred during the process, the calculated C/K factor and the measured cosine phi will be displayed on the screen, the result of having correctly configured the phase relationships (2 times each).





If an error occurs during the process, the following screen will appear:



Conditions for the correct operation of the Plug&Play function:





- ✓ The system should be maintained with an inductive cosine of 0.62 to 0.99 throughout the process.
- ✓ The power in the system should be stable. Any major load changes (>10 % in less than 20 seconds) would result in an incorrect calculation of the capacitor power ratings.
- ✓ There must be enough current in the system at the regulator's input, i.e., >100 mA AC.
- ✓ If the load is unbalanced, the correct operation of the Plug&Play function will depend on the phase to which the current transformer is connected.
- ✓ The correct values for Program (**“6.1.5.- STAGE'S CONFIGURATION OF PF CORRECTION EQUIPMENT (CONFIGURATION PROGRAM)”**) and Number of steps (**“6.1.7.- SELECTION OF THE NUMBER OF STAGES”**) must be configured beforehand.

6.1.2.- COS φ TARGET

To set-up this parameter, use the keys   until the cursor  points to the option **Cos**, then push .

The parameter allows the setting of the desired PF in the installation. The regulator will control the connection of the necessary number of capacitors to get the maximum approach to the target value. Since the regulation is in a stepwise mode, the regulator will add a new step when the demanded power is at least 70% of the lower available step power and will remove a step when the excess is also a 70% of the lower available step power. The cosφ adjustment range is from 0,85 inductive to 0,95 capacitive.

6.1.3.- SMALLER AVAILABLE CAPACITOR STEP

To set-up this parameter, use the keys   until the cursor  points to the option **C/K**, then push .

This parameter, named C/K, indicates the reactive current supplied by the smaller capacitor step, measured at the secondary side of the current transformer (CT). Therefore, the setting value depends on the power of the smaller capacitor step, on the CT ratio and on the supply voltage.

Table 10 gives the setting values of C/K for a 400 V phase to phase supply for different CT ratios and different values of smaller capacitor step (kvar). For conditions other than those given in table, the paragraph “**6.1.4.- C/K PARAMETER CALCULATION**” shows a simple calculation to obtain the C/K value

Table 10: C/K factor according to smaller capacitor power and CT ratio.

CT ratio (Ip/Is)	Smaller capacitor power in kvar, at 400 V ⁽¹⁾														
	2.5	5.00	7.5	10.0	12.5	15.0	20.0	25.0	30.0	37.5	40.0	50.0	60.0	75.0	80.0
150/5	0.12	0.24	0.36	0.48	0.60	0.72	0.96								
200/5	0.09	0.18	0.27	0.36	0.45	0.54	0.72	0.90							
250/5	0.07	0.14	0.22	0.29	0.36	0.43	0.58	0.72	0.87						
300/5	0.06	0.12	0.18	0.24	0.30	0.36	0.48	0.60	0.72	0.90	0.96				
400/5	0.05	0.09	0.14	0.18	0.23	0.27	0.36	0.45	0.54	0.68	0.72	0.90			
500/5		0.07	0.11	0.14	0.18	0.22	0.29	0.36	0.43	0.54	0.58	0.72	0.87		
600/5		0.06	0.09	0.12	0.15	0.18	0.24	0.30	0.36	0.45	0.48	0.60	0.72	0.90	0.96
800/5			0.07	0.09	0.11	0.14	0.18	0.23	0.27	0.34	0.36	0.45	0.54	0.68	0.72
1000/5			0.05	0.07	0.09	0.11	0.14	0.18	0.22	0.27	0.29	0.36	0.43	0.54	0.58
1500/5				0.05	0.06	0.07	0.10	0.12	0.14	0.18	0.19	0.24	0.29	0.36	0.38
2000/5						0.05	0.07	0.09	0.11	0.14	0.14	0.18	0.22	0.27	0.29
2500/5							0.06	0.07	0.09	0.11	0.12	0.14	0.17	0.22	0.23
3000/5							0.05	0.06	0.07	0.09	0.10	0.12	0.14	0.18	0.19
4000/5									0.05	0.07	0.07	0.09	0.11	0.14	0.14

⁽¹⁾ For supply voltages other than 400 V the C/K factor obtained from the table must be multiplied by the ratio (400 / Vsupply)

**IMPORTANT:**

If C/K is adjusted too low the system will connect and disconnect steps with a lower threshold and therefore the number of operations to control the average PF will be higher.

If C/K is adjusted slightly above the required value (10%) the system will react with higher threshold values and therefore the number of operations to control the average PF will be lower. Wear of PF compensation is also lower.

6.1.4.- C/K PARAMETER CALCULATION

For conditions other than those given in **Table 10** the parameter C/K can be calculated as follows.

The necessary data to perform the calculation are: The power of the smaller capacitor step, Q and the supply voltage V. Then, the smaller step reactive current, I_C , can be calculated as:

$$I_C = \frac{Q}{\sqrt{3} \cdot V}$$

The current transformer ratio, K : $K = I_{prim} / I_{sec}$

where :

I_{prim} is the CT primary rated current (i.e. in a 250/5 CT , the primary rated current is 250 A)

I_{sec} is the CT secondary rated current , usually 5 A

the C/K parameter would be: $C / K = \frac{I_C}{K} = \frac{Q}{\sqrt{3} \cdot K \cdot V}$





Example: Assume a PF equipment at 500V where the smaller capacitor is rated to 60kvar and the CT has a ratio 500/5. The calculation would be as follows:

K ratio: $K = 500 / 5 = 100$

Smaller capacitor current : $I_C = \frac{60.1000}{\sqrt{3} \cdot 500} = 69,28 A$

C/K : $C / K = \frac{I_C}{K} = \frac{69,28}{100} = 0,69$

6.1.5.- STAGE'S CONFIGURATION OF PF CORRECTION EQUIPMENT (CONFIGURATION PROGRAM)

To set-up this parameter, use the keys   until the cursor  points to the option **Prog** , then push .

During the set-up of this parameter, the screen shows alternatively one of the options T1 to T6 and the $\cos \varphi$.

PF correction equipment is constituted by several capacitor stages, which may have different power ratings. Taking as base the power of the smaller capacitor stage, the powers of the rest

of stages can be given in terms of multiples of the smaller step. Then we could state the configuration (configuration program) of PF equipment as:

Program 1:1:1... All the stages have the same power in kvar.

Program 1:2:2... The second stage and successive have a power double than the 1st step.





Program 1:2:4... The 2nd step has double power and the successive quadruple that the 1st step

The default factory setting of **computer MAX** devices is **1:1:1:1**. The available programs are:

Table 11: Available configuration programs for computer MAX





Screen Indication	Stage's configuration
111	1:1:1:1:1....
122	1:2:2:2:2....
124	1:2:4:4:4....
248	1:2:4:8:8....
112	1:1:2:2:2....
224	1:2:2:4:4....
123	1:2:3:3:3....
234	1:2:3:4:4....
236	1:2:3:6:6....
246	1:2:4:6:6....

6.1.6.- CONNECTION AND RE-CONNECTION TIME SETTINGS

To set-up this parameter, use the keys   until the cursor  points to the option **Delay**, then push .

This parameter sets up the delay times of the device. The setting value, **Tc**, is the delay time between the connection or disconnection of successive capacitor stages. The parameter also sets up the called reconnection delay, **Tr**, which is the minimum time that must elapse between the disconnection of a C stage and its following connection. The range of **Tc** settings goes from 4 s to 999 s. **Tr** is automatically set to 5 times **Tc** (Notice that **Tr** is needed to guarantee the capacitors discharge). **The default setting of Tc is 10 s.**





6.1.7.- SELECTION OF THE NUMBER OF STAGES

To set-up this parameter, use the keys   until the cursor  points to the option **Steps**, then push .

This setting allows the selection of the number of stages of the PF compensation equipment. Depending on the device type, **computer MAX 6** or **MAX 12** we can select up to 6 or 12 stages.

If the number of stages is less than 6 or 12 respectively in **computer MAX 6** or **MAX 12** the relay number 6 or 12 is automatically assigned as alarm relay. See “5.4.- ALARM RELAY”.

6.1.8.- U, I PHASE ANGLE SETTING.

To set-up this parameter, use the keys   until the cursor  points to the option **Phase**, then push .

This parameter permits the adaptation of the regulator to different options of connection of voltage and current measurement in the three phase system. The default assumed connection is the one shown in **Figure 4** and **Figure 5**, i.e., the current transformer placed in phase L1 and voltage measurement between phases L2 (terminal C) and L3 (terminal D).

Sometimes it's difficult to guarantee this connection or even check how it is. To adapt to this unknown situations the **computer MAX** devices allow the selection of different options, T1 to T6, as shown in **Table 12**. To select the right option during start up, you should verify that there is load and that the loads are mainly inductive with a $\cos \varphi$ between 0,7 y 1. In this situation try the different options until the $\cos \varphi$ screen shows a value between 0,7 and 1.

Table 12: Phase shift options in computer MAX

Screen	U-I phase shift at $\cos\varphi=1$	V measured in phases	CT placed in phase
T1	30°	L3-L2	L3
T2	270°	L3-L2	L1
T3	150°	L3-L2	L2
T4	210°	L3-L2	L3 (P1-P2 or S1-S2 reversed)
T5	90°	L3-L2	L1 (P1-P2 or S1-S2 reversed)
T6	330°	L3-L2	L2 (P1-P2 or S1-S2 reversed)

6.1.9.- PROGRAMMING THE CT RATED CURRENT (PRIMARY).





The set-up of this parameter can be selected at the bottom of the menu options. Use the  

keys until the bottom red LED  is flashing and push .

The display will show the assumed CT primary current. Set the value according to the CT used to measure installation current. The adjustment range is from 0 to 999 and with the x10 option allows a rated primary current up to 9990 A. By default the secondary of CT is assumed to be 5 A.

6.2.- SET-UP MENU AND PROCEDURE

6.2.1.- HOW TO ACCESS THE SET-UP MENU



To access the set-up menu, press the key  for more than 1s (This is designated as long push in **Table 13**, which gives a summary of the set-up procedure). The pointer  starts blinking and points to the parameter to be adjusted. Select the parameter by means of the keys  .

After the long push and in case that all the capacitor stages are disconnected, the device jumps to the set-up status. In case that there are some stages connected, keep the key  pushed while the regulator disconnects the connected stages sequentially and respecting the programmed delay time. Once all the stages have been disconnected the device enters the set-up status and allows the adjustment of the different parameters.

A schematic diagram of the set-up menu showing the different navigation paths is shown in **Table 13**. The meanings of the different adjustable parameters have been explained in “**6.1.- CONFIGURABLE PARAMETERS**”.

6.2.2.-NAVIGATION SCHEMATIC

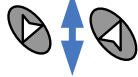
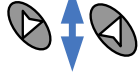
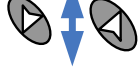
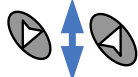
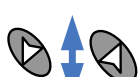
Table 13: Menu navigation schematic.

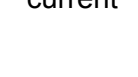
Parameter selection	Device screen display	See paragraph
<p> Long push to start set-up</p> <p>Plug&Play </p> <p>cosφ target </p> <p>C/K </p> <p>Program </p> <p>Delay times </p> <p>Nr of stages </p> <p>CT phase </p> <p>CT primary current </p>		<p>6.1.1.</p> <p>6.1.2</p> <p>6.1.3 6.1.4</p> <p>6.1.5</p> <p>6.1.6</p> <p>6.1.7</p> <p>6.1.8</p> <p>6.1.9</p>

IMPORTANT :

While the device is in set-up mode, if there isn't any key pushing for more than 3 minutes, the device returns automatically to normal RUN mode and none of the previously edited parameters are changed nor saved. To exit the set-up menu changing the edited parameters, push the key  for more than 1s.

7.- RUN STATUS

Once the device has been configured according to installation needs it can be set to RUN mode to regulate the PF of the installation. RUN mode is the default mode after exiting the set-up menu or after the device start (supply connection followed by a short initialisation period). When the device is in RUN mode it can reach one of the following status:









A.- Normal RUN status (Absence of alarm): In this status the device performs the automatic PF regulation, connecting and disconnecting the capacitor stages according to installation needs. In this status the user can access to the measurement of different parameters and can also force the manual connection or disconnection of capacitor stages as described in **“7.1.- FUNCTIONS OF THE DEVICE IN NORMAL RUN MODE”**.

B.- Alarm status: If any of the anomalous situations described in **“5.3.- ERRORS AND ERROR MESSAGES”** occur, the device jumps to alarm status and displays the error code. Depending on the error type the regulator may perform the disconnection of all the stages or continue regulating the PF as in normal RUN.

7.1.- FUNCTIONS OF THE DEVICE IN NORMAL RUN MODE.

In the normal RUN mode the **computer MAX** can perform the following functions:

Table 14: Functions of the device in normal run mode.

Functions of the device in normal run mode	
 long	Manual connection of capacitor stages: Keep the key pushed during more than 1s and the regulator will sequentially connect the different steps, following the normal program and respecting the delay time t_{on}
 long	Manual disconnection of capacitor stages: Keep the key pushed during more than 1s and the regulator will sequentially disconnect the different steps, following the normal program and respecting the delay time t_{off} set in the set-up procedure
	Displaying the number of connected steps: If both keys are simultaneously pushed the device displays the Nr of connected steps. Remember the difference between step and stage (“2.3.3.- STAGES AND STEPS”)
 short	Parameters measurement: Performing successive short pushing of this key (<1 s), the user can travel along several display screens showing the values of the following parameters: (cos) , cosinus ϕ of the installation ; (I) , mains current; (THD), THD of mains current; (V) , Mains voltage; (I, MAX), Maximum value of mains current since the last clear; (V MAX), Maximum value of mains voltage since the last clear. The displayed parameter is pointed by the cursor 
 short	Parameters measurement: Performing successive short pushing of this key (<1 s), the user can travel through the readings of the same parameters described above but in reverse order.
 long	Start the SET-UP mode: Performing a long push of this key (<1 s), the device jumps to set-up mode.
 MAX	Clear MAX values: Performing a long push of this key (<1 s) while the cursor  is pointing to MAX , the computer MAX clears the maximum values of voltage and current recorded since the last clear.

7.2.- computer MAX BEHAVIOUR IN ALARM MODE

In case that the **computer MAX** detects an error during normal operation (see “**5.3.- ERRORS AND ERROR MESSAGES**”), the screen displays an error code and the behaviour of the device is as described in **Table 15**

Table 15: Computer MAX behaviour under alarm conditions

ERROR message	Description	Possible cause and computer MAX behaviour
<i>E01</i>	Measured current below threshold (0,05A measured at the secondary side of CT)	Possible causes: Low load or CT not connected. The device shows the RUN LED and the screen with everything blinking zeros and does not connect any relays
<i>E02</i>	Over-compensation. The controller demands for stages disconnection and they are all disconnected	Possible causes: C/K not properly adjusted None of the relays will connect.
<i>E03</i>	Sub-compensation. The controller demands for stages connection and they are all connected.	Possible causes: C/K not properly adjusted All the relays will remain connected, except the alarm relay if exists (see “ 5.4.- ALARM RELAY ”)
<i>E04</i>	Overcurrent. The measured current is 20% above the rated current (primary of CT)	Possible causes: C/K not properly adjusted Alarm relay, if exists, disconnects (see “ 5.4.- ALARM RELAY ”). Although the regulation may be wrong, the device tries to regulate the PF normally.
<i>E05</i>	Overvoltage. The measured voltage is 15% above rated voltage.	Possible causes: Connection to a wrong supply voltage. Alarm relay, if exists, disconnects (see “ 5.4.- ALARM RELAY ”). Although the regulation may be wrong, the device tries to regulate the PF normally.

8.- TECHNICAL FEATURES

AC Power supply				
Voltage measurement circuit				
Connection	Connect preferably to phases L2-L3			
Rated voltage	480 V ~ , 400 V ~ , 230 V ~ o 110 V ~ + 15% -10% (depending on model)			
Frequency	45 ... 65 Hz			
Consumption	110 V~	230 V~	400 V~	480 V~
	7 ... 10 VA	7.4 ... 9.9 VA	5 ... 8.8 VA	8.7 ... 10.7 VA
Installation category	CAT III 300 V			
Current measurement circuit				
Connection	Connect preferably to phase L1			
Rated current (In)	.../5A			
Current measurement margin	0.05 ... 5A (Maximum overload +20%)			
Installation category	CAT III 300 V			
Measurement accuracy				
Voltage measurement	1 %			
Current measurement	1 %			
cos φ measurement	2 % ± 1 digit			
Relays outputs				
Quantity	computer MAX 6		computer MAX 12	
	6		12	
Max. voltage open contacts	250V ~			
Max. current (1 relay)	6 A~ , AC1			
Max. current (Terminal connection)	12 A~			
User interface				
Display	3 digits, 7 segments + 20 icons			
Keyboard	3 keys			
LED	2 LED			
Environmental features				
Operating temperature	-20°C... +60°C			
Storage temperature	-20°C ... +70°C			
Relative humidity (non-condensing)	5 ... 95%			
Maximum altitude	2000 m			
Protection degree	IP30 Front panel: IP40			
Mechanical features				
Dimensions (Figure 7)	144 x 144 x 62.5 mm			
Weight	56 gr			
Surround	Self-extinguishing V0 plastic			
Attachment	Panel			
Insulation	Protection against electrical shock with double insulation (device Clase II) according to EN 61010-1			
Standard				
Safety requirements for electrical equipment for measurement	UNE EN 61010 : 2010			

(Continuation) Standard	
Electromagnetic compatibility (EMC) - Part 3-2: Limits - Limits for harmonic current emissions (equipment input current <= 16 A per phase)	UNE EN 61000-3-2:2014
Electromagnetic compatibility (EMC) - Part 3-3: Limits - Limitation of voltage changes, voltage fluctuations and flicker in public low-voltage supply systems, for equipment with rated current <= 16 A per phase and not subject to conditional connection	UNE EN 61000-3-3:2013
Electromagnetic compatibility (EMC) -- Part 4-2: Testing and measurement techniques - Electrostatic discharge immunity test	UNE EN 61000-4-2:2010
Electromagnetic compatibility (EMC) - Part 4-4: Testing and measurement techniques - Electrical fast transient/burst immunity test	UNE EN 61000-4-4:2013
Electromagnetic compatibility (EMC) -- Part 4-8: Testing and measurement techniques - Power frequency magnetic field immunity test	UNE EN 61000-4-8:2011
Electromagnetic compatibility (EMC) - Part 4-5: Testing and measurement techniques - Surge immunity test	UNE EN 61000-4-5:2015
Electromagnetic compatibility (EMC) -- Part 4-11: Testing and measurement techniques - Voltage dips, short interruptions and voltage variations immunity tests	UNE EN 61000-4-11:2005
Electromagnetic compatibility. Generic emission standards. Part 2: industrial environment.	EN 50081-2:1994
Electromagnetic compatibility. Generic immunity standard. Part 1: residential, commercial and light industry.	EN 50082-1:1998
Electromagnetic compatibility. Generic immunity standard. Part 2: industrial environment.	EN 50082-2:1996
	UL 94

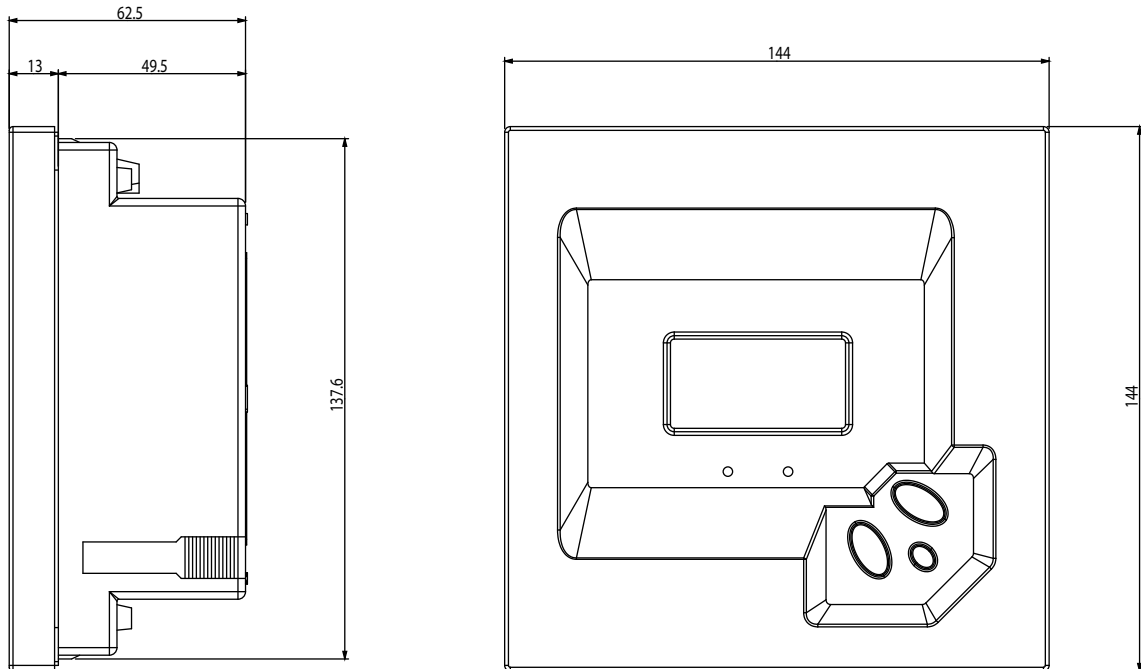

Figure 7: computer MAX dimensions.

9.- MAINTENANCE AND TECHNICAL SERVICE

The **computer MAX 6** and **MAX 12** do not require a special maintenance program. In case that some adjustments or maintenance might be necessary it must be performed by dully qualified staff and respecting the required safety procedures.

In the case of any query in relation to device operation or malfunction, please contact the **CIRCUTOR, SA** Technical Support Service.

Technical Assistance Service

Vial Sant Jordi, s/n, 08232 - Viladecavalls (Barcelona)

Tel: 902 449 459 (España) / +34 937 452 919 (outside of Spain)

email: sat@circutor.com

10.- GUARANTEE

CIRCUTOR guarantees its products against any manufacturing defect for two years after the delivery of the units.

CIRCUTOR will repair or replace any defective factory product returned during the guarantee period.



- No returns will be accepted and no unit will be repaired or replaced if it is not accompanied by a report indicating the defect detected or the reason for the return.
- The guarantee will be void if the units has been improperly used or the storage, installation and maintenance instructions listed in this manual have not been followed. "Improper usage" is defined as any operating or storage condition contrary to the national electrical code or that surpasses the limits indicated in the technical and environmental features of this manual.
- **CIRCUTOR** accepts no liability due to the possible damage to the unit or other parts of the installation, nor will it cover any possible sanctions derived from a possible failure, improper installation or "improper usage" of the unit. Consequently, this guarantee does not apply to failures occurring in the following cases:
 - Overvoltages and/or electrical disturbances in the supply;
 - Water, if the product does not have the appropriate IP classification;
 - Poor ventilation and/or excessive temperatures;
 - Improper installation and/or lack of maintenance;
 - Buyer repairs or modifications without the manufacturer's authorisation.

11.- CE CERTIFICATE

DECLARACION UE DE CONFORMIDAD

La presente declaración de conformidad se expide bajo la exclusiva responsabilidad de CIRCUTOR con dirección en Vial Sant Jordi, s/n - 08232 Viladecavalls (Barcelona) España

Producto:

Reguladores automáticos de energía reactiva para maniobra estática

Serie:

Computer MAX 6m, Computer MAX 12m, Computer MAX-f 6m, Computer MAX-f 12m

Marca:

CIRCUTOR

El objeto de la declaración es conforme con la legislación de armonización pertinente en la UE, siempre que sea instalado, mantenido y usado en la aplicación para la que ha sido fabricado, de acuerdo con las normas de instalación aplicables y las instrucciones del fabricante

2014/35/UE: Low Voltage Directive 2014/30/UE: Electromagnetic Compatibility Directive
2011/65/UE: RoHS2 Directive

Esta en conformidad con la(s) siguiente(s) norma(s) u otras documentado(s) siguiente(s):

IEC 61000-1:2009+AMD1:2016 CV Ed 3.0 IEC 61000-6-2:2016 Ed 3.0
IEC 61000-6-4:2006+AMD1:2010 CV Ed 1.1 IEC 60871:2007+AMD1:2016+AMD2:2014 CV Ed 1.1

Año de marcado "CE":

2009

EU DECLARATION OF CONFORMITY

This declaration of conformity is issued under the sole responsibility of CIRCUTOR with registered address at Vial Sant Jordi, s/n - 08232 Viladecavalls (Barcelona) Spain

Product:

Power factor regulators for static switching

Series:

Computer MAX 6m, Computer MAX 12m, Computer MAX-f 6m, Computer MAX-f 12m

Brand:

CIRCUTOR

The object of the declaration is in conformity with the relevant EU harmonisation legislation, provided that it is installed, maintained and used for the application for which it was manufactured, in accordance with the applicable installation standards and the manufacturer's instructions

2014/35/UE: Low Voltage Directive 2014/30/UE: Electromagnetic Compatibility Directive
2011/65/UE: RoHS2 Directive

It is in conformity with the following standard(s) or other regulatory document(s):

IEC 61000-1:2009+AMD1:2016 CV Ed 3.0 IEC 61000-6-2:2016 Ed 3.0
IEC 61000-6-4:2006+AMD1:2010 CV Ed 1.1 IEC 60871:2007+AMD1:2016+AMD2:2014 CV Ed 1.1

Year of CE mark:

2009

DECLARATION UE DE CONFORMITE

La présente déclaration de conformité est délivrée sous la responsabilité exclusive de CIRCUTOR dont l'adresse postale est Vial Sant Jordi, s/n - 08232 Viladecavalls (Barcelona) Espagne

Produit:

Régulateurs automatiques d'énergie réactive pour manoeuvre statique

Série:

Computer MAX 6m, Computer MAX 12m, Computer MAX-f 6m, Computer MAX-f 12m

Marque:

CIRCUTOR

L'objet de la déclaration est conforme à la législation d'harmonisation pertinente dans l'UE, à condition d'avoir été installé, entretenu et utilisé dans l'application pour laquelle il a été fabriqué, conformément aux normes d'installation applicables et aux instructions du fabricant

2014/35/UE: Low Voltage Directive 2014/30/UE: Electromagnetic Compatibility Directive
2011/65/UE: RoHS2 Directive

Il est en conformité avec la(s) suivante(s) norme(s) ou autre(s) document(s) réglementaire(s):

IEC 61000-1:2009+AMD1:2016 CV Ed 3.0 IEC 61000-6-2:2016 Ed 3.0
IEC 61000-6-4:2006+AMD1:2010 CV Ed 1.1 IEC 60871:2007+AMD1:2016+AMD2:2014 CV Ed 1.1

Année de marquage "CE":

2009



Viladecavalls (Spain), 19/10/2017
General Manager: Ferran Gil Torné



KONFORMITÄTSEKTLÄRUNG UE

Vorliegende Konformitätserklärung wird unter alleiniger Verantwortung von CIRCUTOR mit der Anschrift, Vial Sant Jordi, s/n - 08233 Viladecavalls (Barcelona), Spanien, ausgestellt.

Produkt:

automatischer Blindleistungsregler für statische Betätigung

Serie:

Computer MAX 6m, Computer MAX 12m, Computer MAX-f 6m, Computer MAX-f 12m

Marke:

CIRCUTOR

Der Gegenstand der Konformitätserklärung ist konform mit den geltenden Vorschriften zur Harmonisierung der EU, sofern die Installation, Wartung und Verwendung den Anweisungen des Herstellers entspricht, gemäß den geltenden Installationsstandards und der Vorgaben des Herstellers. Entsprechend:

2014/53/UE: Low Voltage Directive 2014/30/UE: Electromagnetic Compatibility Directive
2011/65/UE: RoHS2 Directive

Es besteht Konformität mit den/ihnen folgenden/folgenden Norm/Normen oder sonstigen/sonstiger (Regelwerk/Richtlinie/Klass)

IEC 61000-1:2010-AMD1:2016 CSV E6 3.0 IEC 61000-6-2:2016 Ed 3.0
IEC 61000-4-2006-AMD1:2010 CSV E6 2.1 IEC 60941:2010-AMD1:2015-AMD2:2014 CSV E6 5.2

Im der CE-Kennzeichnung:

2009



DECLARAÇÃO DA UE DE CONFORMIDADE

A presente declaração de conformidade é expedida sob a exclusiva responsabilidade da CIRCUTOR com morada em:

Vial Sant Jordi, s/n - 08233 Viladecavalls (Barcelona) Espanha

Produto:

Reguladores automáticos de energia reativa para manobra estática

Série:

Computer MAX 6m, Computer MAX 12m, Computer MAX-f 6m, Computer MAX-f 12m

Marca:

CIRCUTOR

O objeto da declaração está conforme a legislação de harmonização pertinente na UE, sempre que seja instalado, mantido e utilizado na aplicação para a qual foi fabricado, de acordo com as normas de instalação aplicáveis e as instruções do fabricante.

2014/53/UE: Low Voltage Directive 2014/30/UE: Electromagnetic Compatibility Directive
2011/65/UE: RoHS2 Directive

Está em conformidade com a(s) seguinte(s) norma(s) ou outro(s) documento(s) normativo(s):

IEC 61000-1:2010-AMD1:2016 CSV E6 3.0 IEC 61000-6-2:2016 Ed 3.0
IEC 61000-4-2006-AMD1:2010 CSV E6 2.1 IEC 60941:2010-AMD1:2015-AMD2:2014 CSV E6 5.2

Ano de marcação "CE":

2009

Viladecavalls (Spain), 19/10/2017
General Manager: Ferran Gil Torné



Anno di marcatura "CE":

2009



DICHIARAZIONE DI CONFORMITÀ UE

La presente dichiarazione di conformità viene rilasciata sotto la responsabilità esclusiva di CIRCUTOR, con sede in:

Vial Sant Jordi, s/n - 08233 Viladecavalls (Barcelona) Spagna

prodotto:

Regolatori automatici di energia reattiva per manovra statica

Series:

Computer MAX 6m, Computer MAX 12m, Computer MAX-f 6m, Computer MAX-f 12m

MARCHIO:

CIRCUTOR

L'oggetto della dichiarazione è conforme alla direttiva normativa di armonizzazione dell'Unione Europea, a condizione che venga installato, mantenuto e utilizzato nell'ambito dell'applicazione per cui è stato prodotto, secondo le norme di installazione applicabili e le istruzioni del produttore.

2014/53/UE: Low Voltage Directive 2014/30/UE: Electromagnetic Compatibility Directive
2011/65/UE: RoHS2 Directive

È conforme alle seguenti normative o altri documenti (normativi):

IEC 61000-1:2010-AMD1:2016 CSV E6 3.0 IEC 61000-6-2:2016 Ed 3.0
IEC 61000-4-2006-AMD1:2010 CSV E6 2.1 IEC 60941:2010-AMD1:2015-AMD2:2014 CSV E6 5.2



CIRCUTOR, SA – Vial Sant Jordi, s/n
08232 Viladecavalls (Barcelona) Spain
(+34) 937 452 900 – info@circutor.com



DEKLARACJA ZGODNOŚCI UE

Niniejsza deklaracja zgodności zostaje wydana na wyłączną odpowiedzialność firmy CIRCUTOR z siedzibą pod adresem: Vial Sant Jordi, s/n – 08232 Viladecavalls (Barcelona) Hiszpania

Przedmiot:

Automatyczne regulatory energii biernej do przelączania statycznego

Model:

Computer MAX 6m, Computer MAX 12m, Computer MAX-f 6m, Computer MAX-f 12m

Model:

CIRCUTOR

Przedmiot deklaracji jest zgodny z odnoszonymi wymaganiami prawodawstwa harmonizacyjnego w Unii Europejskiej, pod warunkiem, że będzie instalowany, konserwowany i użytkowany zgodnie z przeznaczeniem, dla którego został wyprodukowany, zgodnie z instrukcją zastosowaną normami dotyczącymi instalacji oraz instrukcjami producenta

2014/35/EU: Low Voltage Directive 2014/53/EU: Electromagnetic Compatibility Directive
2011/65/EU: RoHS2 Directive

jest zgodny z następującymi normami lub innymi dokumentami normatywnymi:

IEC 61000-1:2005+AMD1:2016 CSV Ed 3.0 IEC 61000-6-2:2016 Ed 3.0
IEC 61000-6-4:2009+AMD1:2010 CSV Ed 1.1 IEC 60847-1:2007+AMD1:2009+AMD2:2014 CSV Ed 5.2

Rok oznakowania "CE":

2009



Viladecavalls (Spain), 15/10/2017
General Manager: Ferran Gil Torné

CIRCUTOR, SA

Vial Sant Jordi, s/n

08232 - Viladecavalls (Barcelona)

Tel.: (+34) 93 745 29 00 - Fax: (+34) 93 745 29 14

www.circutor.com central@circutor.com