

Configuration for version 5.x 690+

DWN		SIZE A	DWG. NO.	RFA
CHK		/1/Partner-serw.oryginal.690.010		ISSUE 12 May 21
APP		SCALE	SHEET	1 OF 8
EDIT	LOC			

## Sequencing and Reference

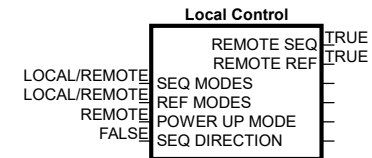
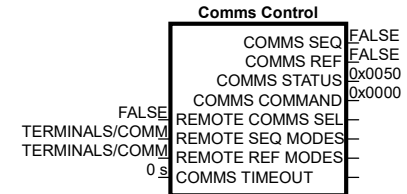
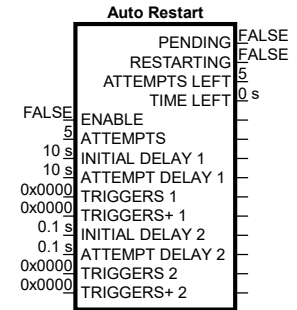

## Communications

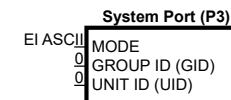
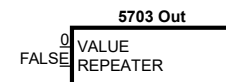
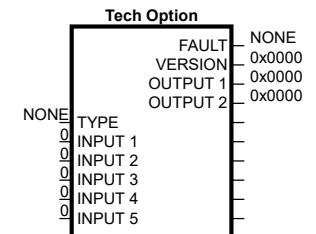
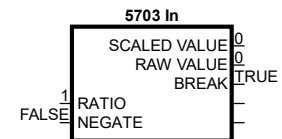

Configuration for version 5.x 690+

DWN			SIZE A	DWG. NO.	RFA
CHK		/1/Partner-serw.oryginal.690.010	ISSUE		12 May 21
APP			SCALE	SHEET	2 OF 8
EDIT	LOC				

# Motor Control

**Autotune**

FALSE ROTATING MODE 0x0000

ACTIVE

FALSE

ENABLE

MODE

TEST DISABLE

**Current Limit**

150 % TRUE

CURRENT LIMIT

REGEN LIM ENABLE

**Dynamic Braking**

TRUE 20 Ohm 30 kW 2s

BRKING

FALSE

ENABLE

BRAKE RESISTANCE

BRAKE POWER

1SEC OVER RATING

**Energy Meter**

FALSE

POWER 0 kW

POWER 0 hp

REACTIVE POWER 0 kVAR

ENERGY USED 32767 kW hr

RESET

**Feedbacks**

DC LINK VOLTS 568 V

TERMINAL VOLTS 0 V

SPEED FEEDBACK RPM 0 rpm

SPEED FEEDBACK REV/S 0 rev/s

SPEED FEEDBACK % 0 %

ENCODER FEEDBACK % 0 %

ENCODER COUNT 0

TORQUE FEEDBACK 0 %

FIELD FEEDBACK 0 %

MOTOR CURRENT % 0 %

MOTOR CURRENT 0 A

\* 19 V

\* 5000

\* FALSE

\* QUADRATURE

FALSE

ENCODER SUPPLY

ENCODER LINES

ENCODER INVERT

ENCODER MODE

QUADRATIC TORQUE

**Fluxing**

LINEAR LAW

\* 0 % V/F SHAPE

\* 0 % FIXED BOOST

\* 0 % AUTO BOOST

\* 0 % ACCELRTN BOOST

FALSE ENERGY SAVING

\* 10 % USER FREQ 1

\* 20 % USER VOLTAGE 1

\* 20 % USER FREQ 2

\* 20 % USER VOLTAGE 2

\* 30 % USER FREQ 3

\* 30 % USER VOLTAGE 3

\* 40 % USER FREQ 4

\* 40 % USER VOLTAGE 4

\* 50 % USER FREQ 5

\* 50 % USER VOLTAGE 5

\* 60 % USER FREQ 6

\* 60 % USER VOLTAGE 6

\* 70 % USER FREQ 7

\* 70 % USER VOLTAGE 7

\* 80 % USER FREQ 8

\* 80 % USER VOLTAGE 8

\* 90 % USER FREQ 9

\* 90 % USER VOLTAGE 9

\* 100 % USER FREQ 10

\* 100 % USER VOLTAGE 10

**Fly Catching**

FALSE

ACTIVE

SETPOINT 0 %

FALSE

VHZ ENABLE

TRUE

VECTOR ENABLE

ALWAYS

START MODE

BIDIRECTIONAL

SEARCH MODE

\* 9 % SEARCH VOLTS

\* 40 % SEARCH BOOST

\* 10 s SEARCH TIME

5 Hz

MIN SEARCH SPEED

\* 3 s REFLUX TIME

**Inj Braking**

ACTIVE

FALSE

\* 0.5 s DEFLUX TIME

\* 9 Hz FREQUENCY

100 % I-LIM LEVEL

\* 2 s DC PULSE

\* 1 s FINAL DC PULSE

\* 2.5 % DC LEVEL

600 s DC LEVEL

TIMEOUT

\* 100 % BASE VOLTS (%)

**Inverse Time**

105 %

60 s

10 s

120 s

IT LIMITING

INVERSE TIME OP 150 %

AIMING POINT

DELAY

DOWN TIME

UP TIME

**Motor Data**

\* CLOSED-LOOP VEC

\* 110 kW POWER

\* 50 HZ BASE FREQUENCY

\* 420 V MOTOR VOLTAGE

\* 220 A MOTOR CURRENT

\* 89.65 A MAG CURRENT

\* 737 rpm NAMEPLATE RPM

\* DELTA MOTOR CONNECTION

\* 8 POLE MOTOR POLES

\* 0.83 POWER FACTOR

\* 2 OVERLOAD

\* 0.1634 Ohm STATOR RES

\* 2.64 mH LEAKAGE INDUCT

\* 22.32 mH MUTUAL INDUCT

\* 358.45 ms ROTOR TIME CONST

**Pattern Gen**

TRUE 3 kHz 0 Hz

DRIVE FREQUENCY

RANDOM PATTERN

FREQUENCY SELECT

\* 3 s DEFLUX DELAY

**Power Loss Ctrl**

FALSE

PWR LOSS ACTIVE

ENABLE

\* 447V TRIP THRESHOLD

20V CONTROL BAND

10 s ACCEL TIME

5 s DECEL TIME

0 % INITIAL STEP

30 s TIME LIMIT

**Regen Cntrl**

TRUE 720 V

FALSE

SYNCHRONIZING

FALSE SYNCHRONIZED

FALSE PHASE LOSS

FALSE CLOSE PRECHARGE

TRUE ENABLE DRIVE STATUS

FALSE SUPPLY FRQ LO

PRECHARGE CLOSED

DC VOLTS DEMAND

FALSE BRAKE MODE

**Slew Rate Limit**

TRUE

500 Hz/s

500 Hz/s

ENABLE

ACCEL LIMIT

DECEL LIMIT

**Slip Comp**

FALSE

ENABLE

\* 150 rpm MOTORING LIMIT

\* 150 rpm REGEN LIMIT

**Speed Loop**

\* 20

\* 100 ms

FALSE

0 %

7 ms

10 ms

0 %

0 %

0 %

NONE

1

110 %

-110 %

110 %

-110 %

FALSE

0 rpm

0 %

0 %

0 %

0 %

0 %

SPEED PROP GAIN

SPEED INT TIME

INT DEFEAT

SPEED INT PRESET

SPEED DMD FILTER

SPEED FBK FILTER

AUX TORQUE DMD

ADAPTIVE THRESH

ADAPTIVE P-GAIN

DIRECT IP SELECT

DIRECT RATIO

DIRECT IP POS LIM

DIRECT IP NEG LIM

SPEED POS LIM

SPEED NEG LIM

TORQ DMD ISOLATE

**Stabilisation**

FALSE

ENABLE

**Torque Limit**

160 %

-150 %

150 %

150 %

FALSE

0 %

0 %

POS TORQUE LIM

NEG TORQUE LIM

MAIN TORQUE LIM

FAST STOP T-LIM

SYMMETRIC LIM

**Voltage Control**

AUTOMATIC

100 %

VOLTAGE MODE

BASE VOLTS

Configuration for version 5.x 690+

DWN			SIZE A	DWG. NO.	RFA
CHK		/1/Partner-serw.oryginal.690.010	ISSUE		12 May 21
APP			SCALE	SHEET	3 OF 8
EDIT	LOC				

# Setpoint Functions

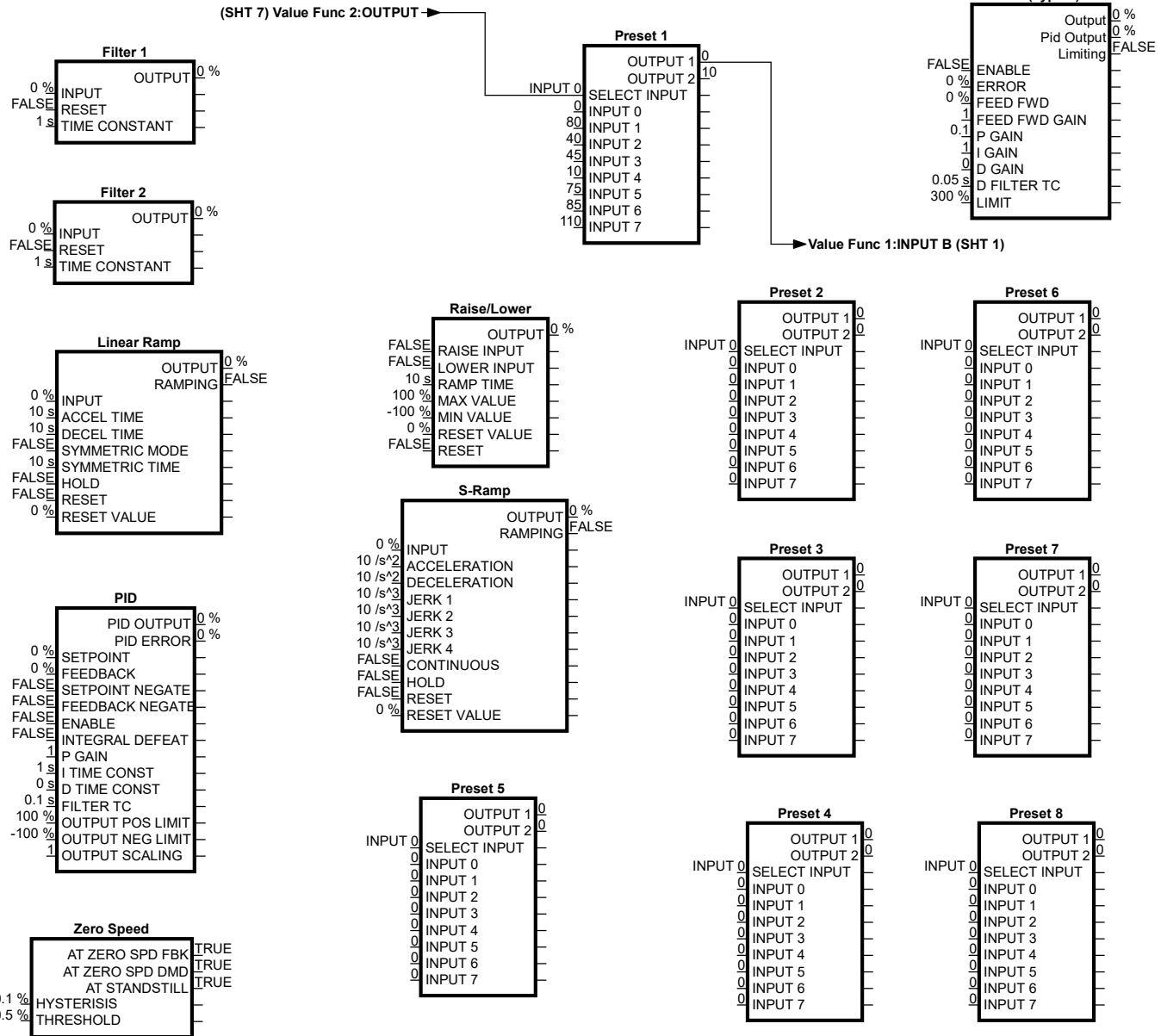

# Trips

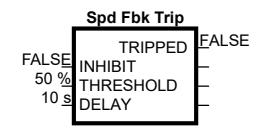
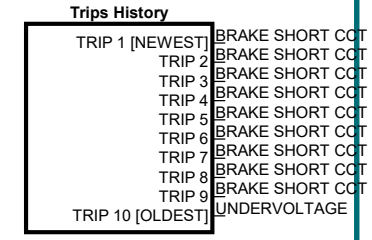

# Hoist/Lift

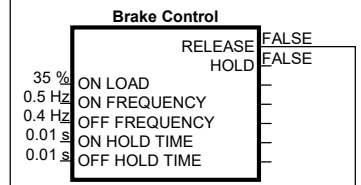

Configuration for version 5.x 690+

DWN			SIZE A	DWG. NO.	RFA
CHK		/1/Partner-serw.oryginal.690.010	ISSUE		12 May 21
APP			SCALE	SHEET	4 OF 8
EDIT	LOC				

# Winder

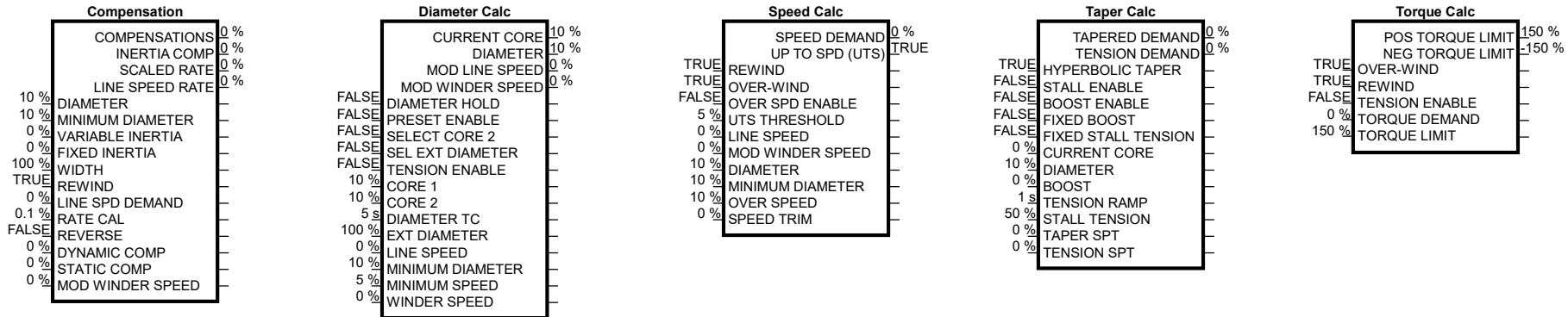

## Inputs Outputs

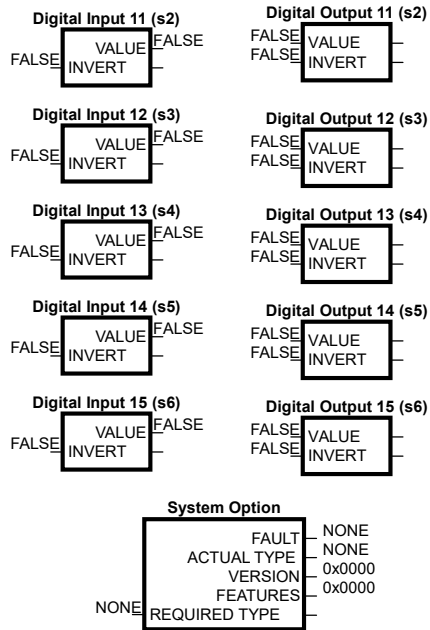

Configuration for version 5.x 690+

## System Board

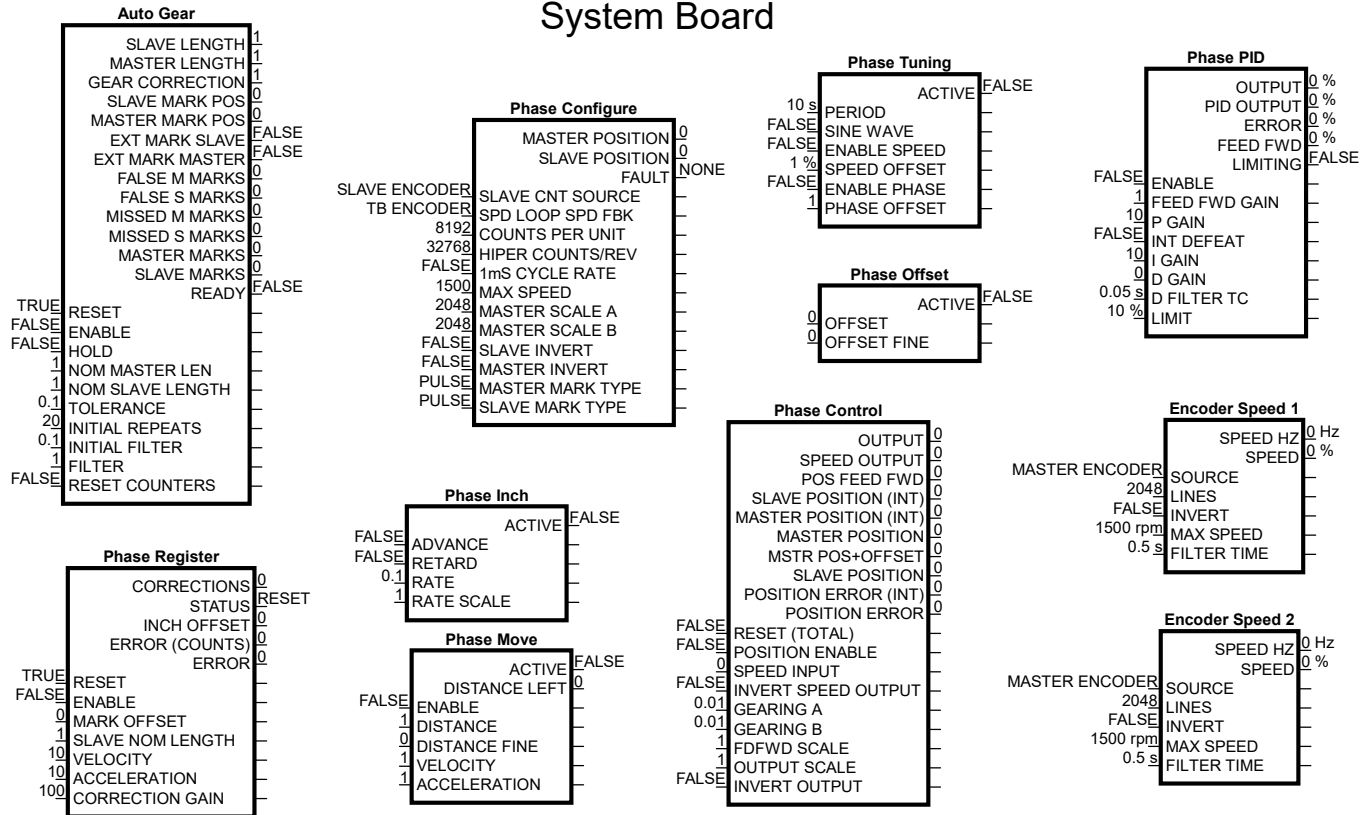

DWN			SIZE A	DWG. NO.	RFA
CHK		/1/Partner-serw.orginal.690.010	ISSUE		12 May 21
APP			SCALE	SHEET	5 OF 8
EDIT	LOC				

# Menus

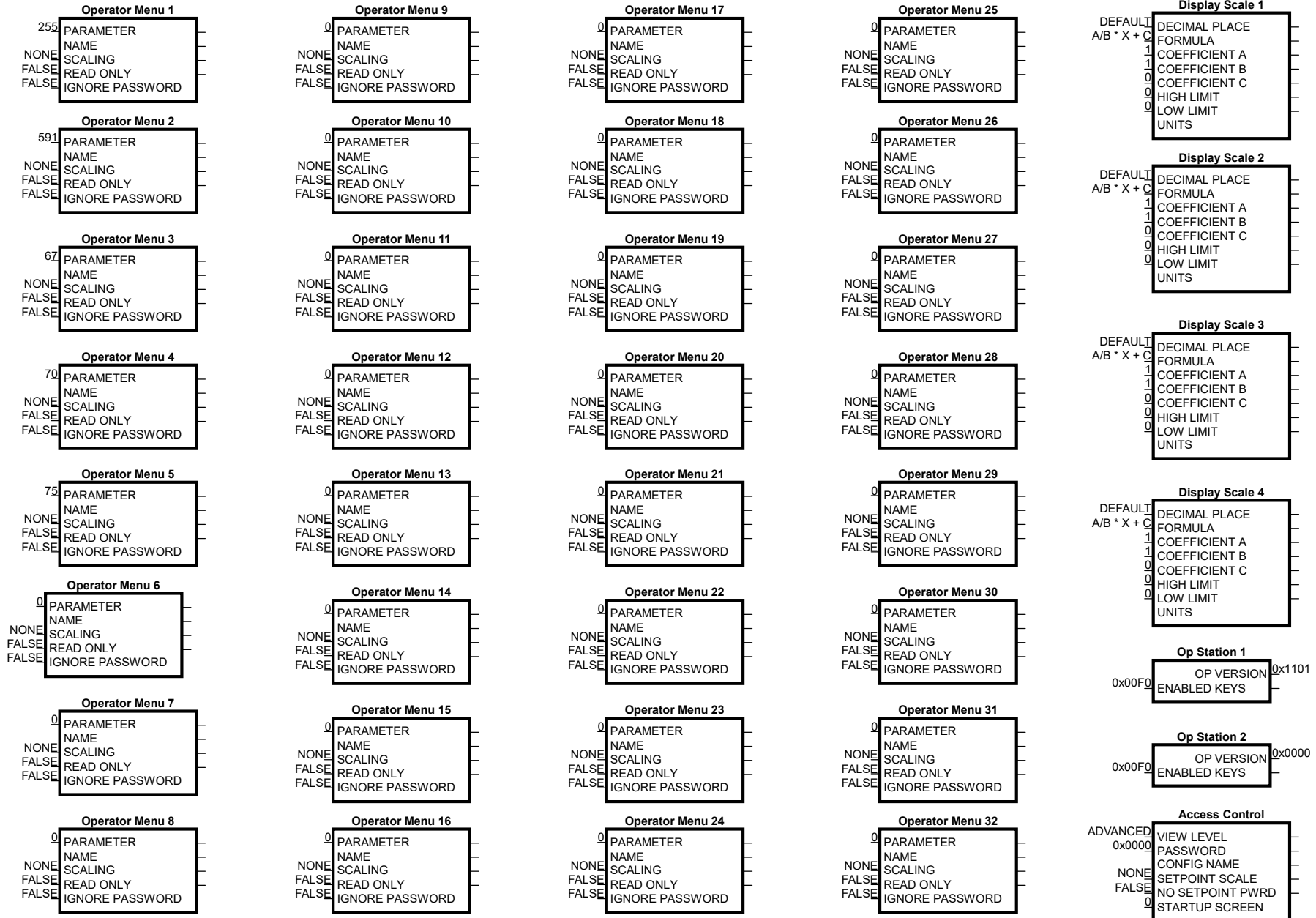

Configuration for version 5.x 690+

DWN			SIZE A	DWG. NO.	RFA
CHK		/1/Partner-serw.oryginal.690.010	ISSUE		12 May 21
APP			SCALE	SHEET	6 OF 8
EDIT	LOC				

# Miscellaneous

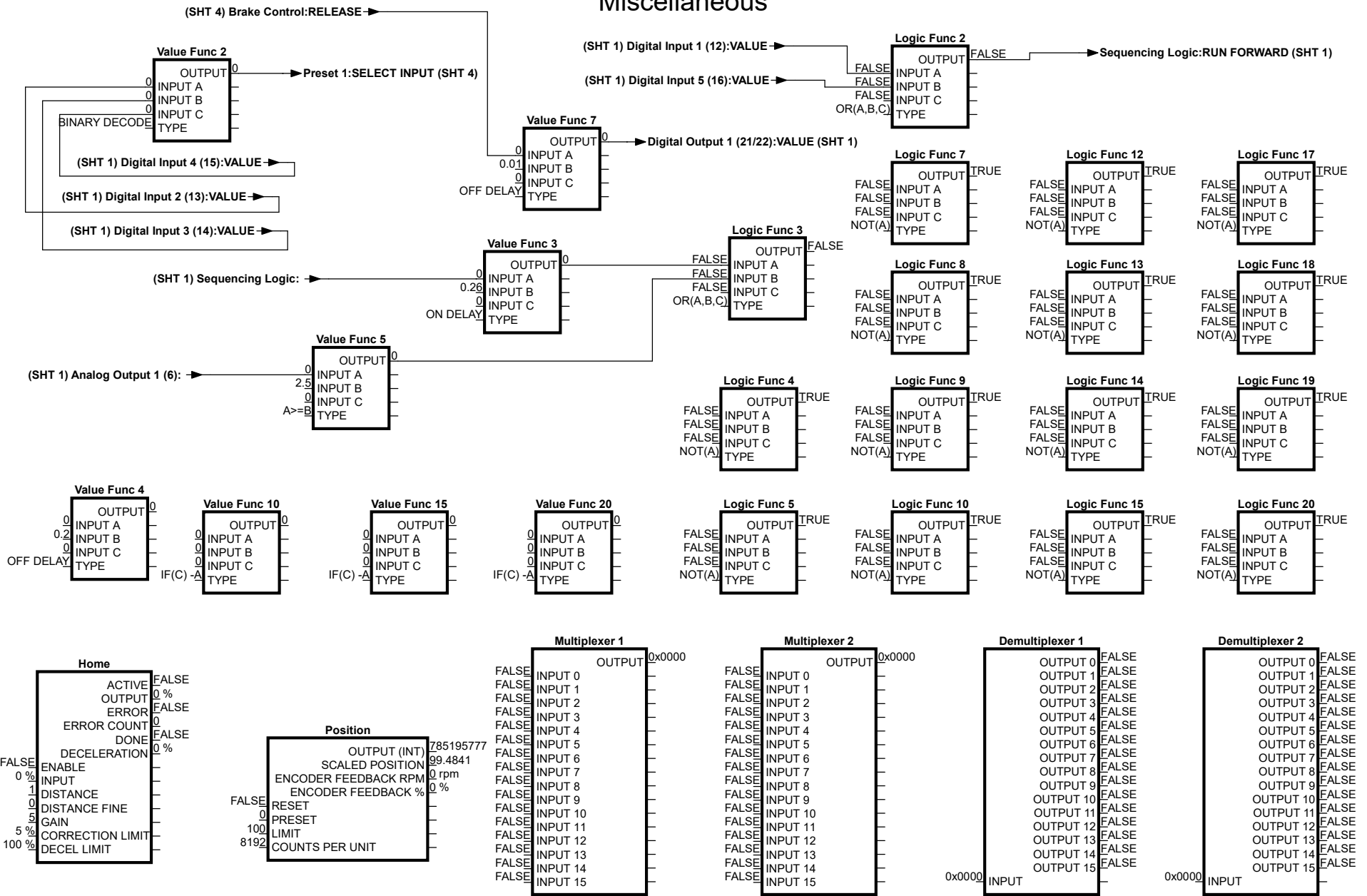

Configuration for version 5.x 690+

DWN			SIZE A	DWG. NO.	RFA
CHK		/1/Partner-serw.oryginal.690.010	ISSUE		12 May 21
APP			SCALE	SHEET	7 OF 8
EDIT	LOC				

# Timers

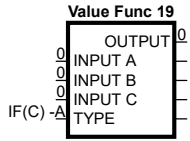
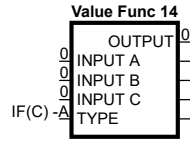
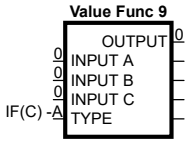
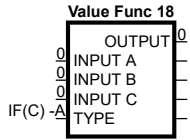
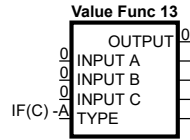
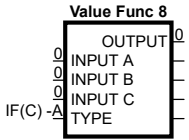
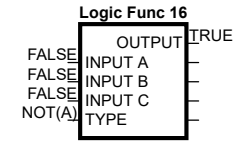
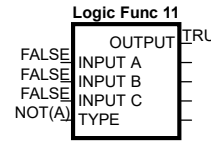
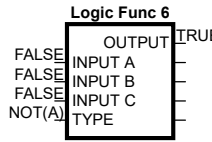
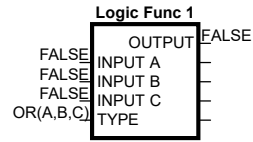
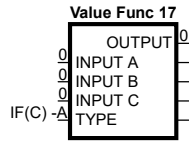
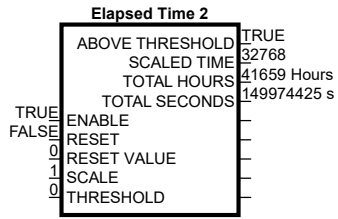
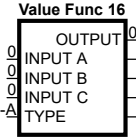
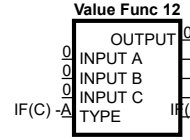
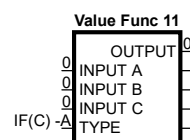
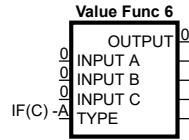
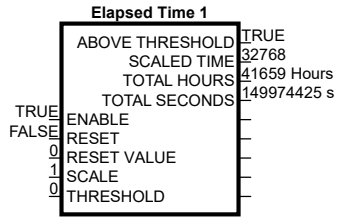

Configuration for version 5.x 690+

DWN			SIZE A	DWG. NO.	RFA
CHK		/1/Partner-serw.oryginal.690.010	ISSUE		12 May 21
APP			SCALE	SHEET	8 OF 8
EDIT	LOC				