

Configuration for version 7.x 590 Plus drive.

*NOTE: Inputs and Outputs in Orange text must be connected to another function block to be processed.

DWN			SIZE A	DWG. NO.	RFA
CHK		/1/LEONI-Im1.590.016	ISSUE		25 Nov 20
APP			SCALE	SHEET	1 OF 3
EDIT	LOC				

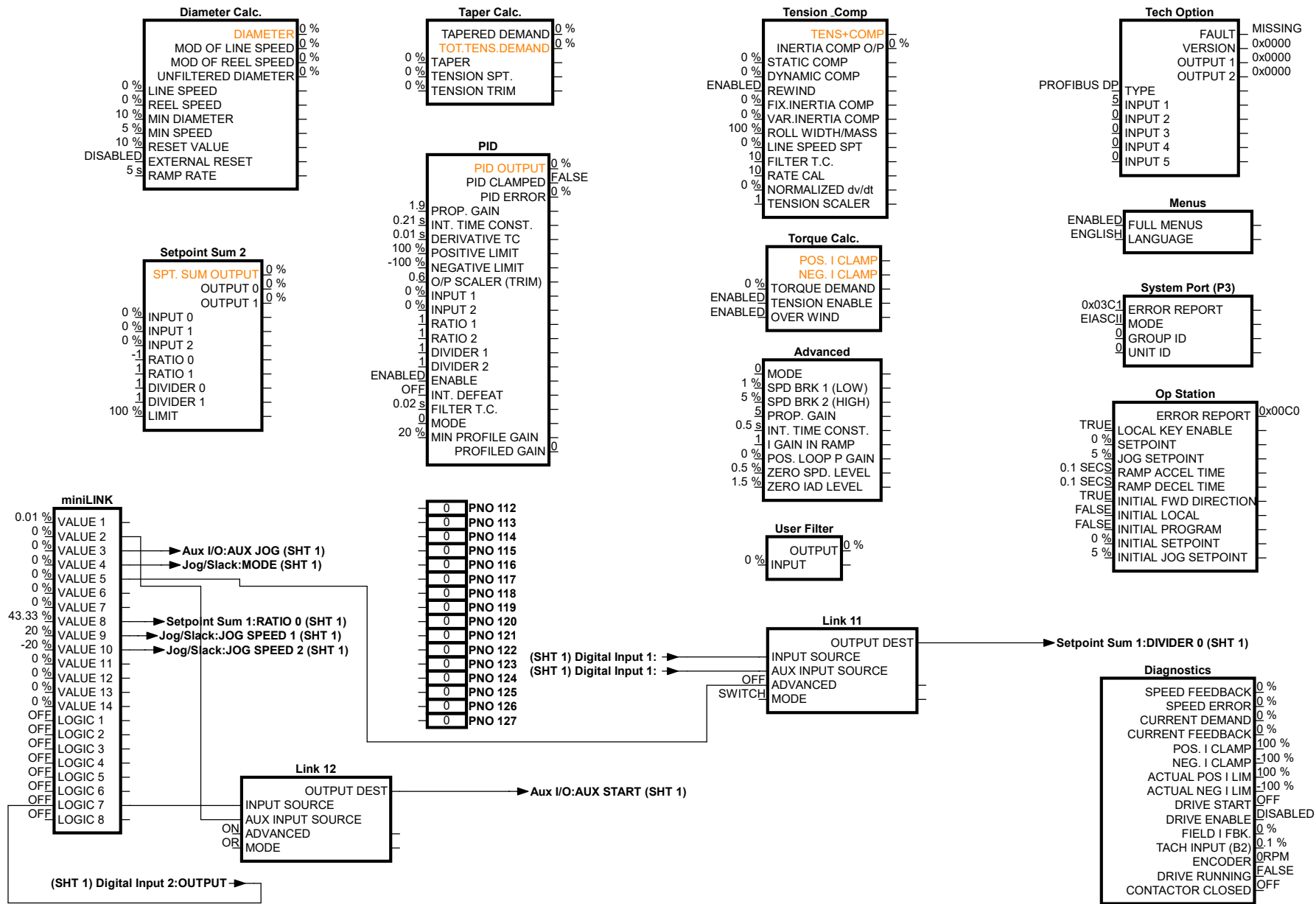

Configuration for version 7.x 590 Plus drive.

***NOTE:** Inputs and Outputs in Orange text must be connected to another function block to be processed.

DWN			SIZE A	DWG. NO.	RFA
CHK		/1/LEONI-lm1.590.016	ISSUE		25 Nov 20
APP			SCALE	SHEET	2 OF 3
EDIT	LOC				

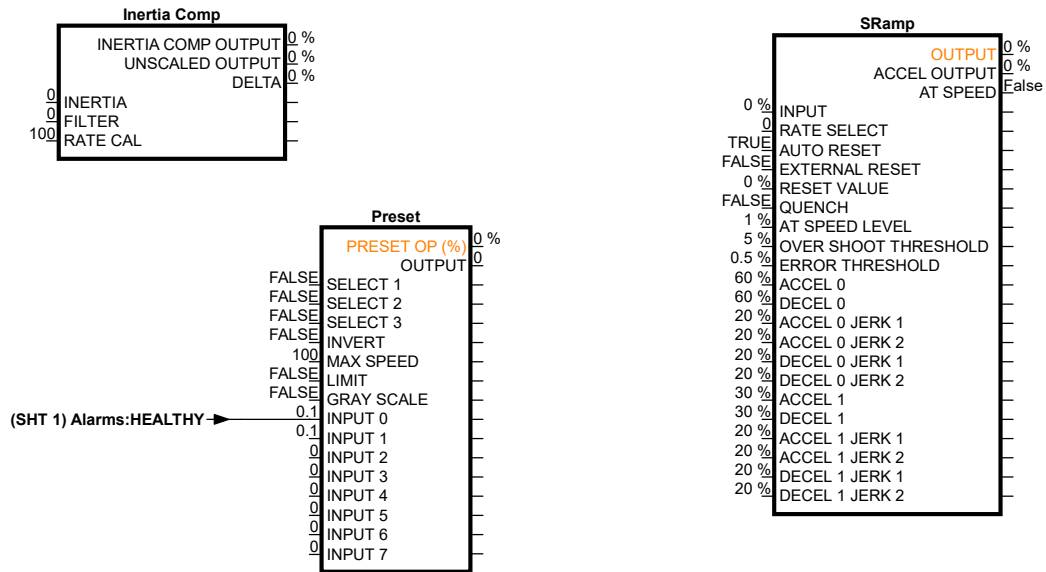

Configuration for version 7.x 590 Plus drive.

*NOTE: Inputs and Outputs in Orange text must be connected to another function block to be processed.

DWN			SIZE A	DWG. NO.	RFA
CHK		/1/LEONI-lm1.590.016	ISSUE		25 Nov 20
APP			SCALE	SHEET	3 OF 3
EDIT	LOC				