

VS65

MV ELECTRONIC SOFT STARTER



VS65

Power Electronics' VS65 medium voltage soft starter is the most reliable and safe solution, fully flexible and customised line-up of MV cells. Rated for applications from 2.3kV to 13.8kV, combines outstanding design and hardware under the most stringent IEC regulations, with advanced technology motor control and safety, that allows a smooth motor starting and stopping under any circumstance.

The VS65 series have been designed and tested under the most demanding environments, together with an easy and rugged user interface allows the user to configure the ultimate motor control and safety protections that will take care of your valuable rotating assets. The VS65 is compartmentalised in 4 independent arc-resistant sections that smartly isolate the medium voltage parts from the low voltage control sections. Fibre optics communicates between the control board and the power stage offering the maximum safety and immunity levels.

Our vertical integration of production and a dedicated project department allow us to offer customised equipment such as input MV protection cells, user terminal strips, communications protocols, ... the VS65 by Power Electronics is your fully integrated tailor made solution, manufactured and factory tested, with the most reliable warranty with unique on-site technical service.

THE MOST RELIABLE
AND SAFE CUSTOMER
ORIENTED SOLUTION

- HIGHEST OPERATOR SAFETY AND BUILT-IN MOTOR PROTECTION FUNCTIONALITIES
- HIGH RELIABILITY AND AVAILABILITY, EASY OPERATION AND INTUITIVE CONTROL
- HIGHEST BREAK AWAY TORQUE
- FULLY CUSTOMISABLE TO THE MOST DEMANDIN REQUIREMENTS

VS65 - TOPOLOGY

SCR POWER STAGE

The power stage consists of high voltage anti-parallel pairs of SCR, which are connected in series depending on the rated voltage. Available from 2,3kV to 13,8kV. Our heavy duty design has a maximum overload capacity of 500% I_n.

The VS65 takes care of its thyristors at any load and temperature condition by means of its built-in SCR snubber circuit and hardware protections. The Snubber circuit balances and protects the SCR stacks to enable a safe start and stop under any circumstance.

Located above the power stage is the trigger circuit. This board communicated through fibre optic to the main control board that precisely sends the triggering pulses to perform a soft start. A fibre optic communication offers maximum safety, total immunity to noise and fast communication rates.

MV CONNECTION AND VACUUM CONTACTORS

The input and output bus bars are tailor made to be ready to plug in to your mains. Top and bottom and either cable or copper bus bar connection options are available.

The VS65 integrates built-in as standard two MV vacuum contactors (line and bypass). The START command initialises the starting sequence by enabling the line contactor, and then the pre-configured soft start is performed. Once the motor reaches the designated point, the bypass contactor is enabled and the line contactor is opened.

This topology isolates the thyristors from the mains at rated speed, hence the VS65 offers 100% efficiency with maximum reliability and protection.

LV USER INTERCONNECTION AND INTERFACE

The user has easy frontal and safe access to the terminal strip (I/O signals) where the centralised control signals will be connected.

The front panel integrates built-in as standard: 3 push buttons (start, stop, E-stop), 1 start mode selector (LOC, REM, STOP), 5 status pilots lamps (running, stop, ready, power supply, warning). Additionally the user can easily configure the soft starter due to its intuitive backlit display and comprehensive documentation.



MV TRANSFORMER FOR AUX. POWER SUPPLY

TRIGGER CIRCUIT

SCR STACKS

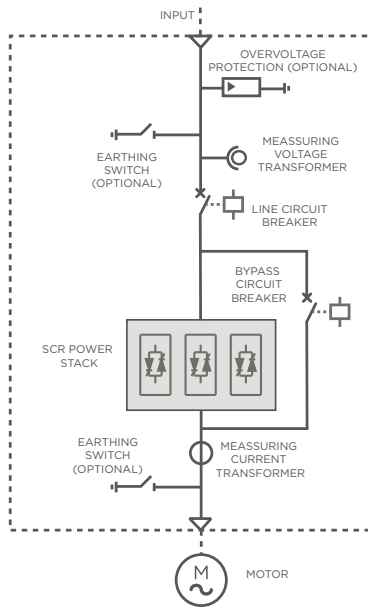
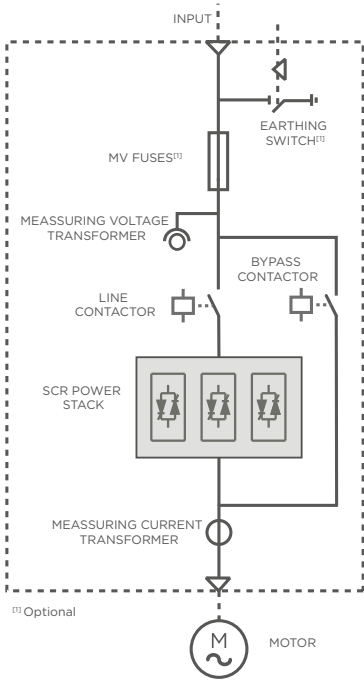

HIGHEST
OPERATION
SAFETY WITH
INTERNAL ARC
APPROVED

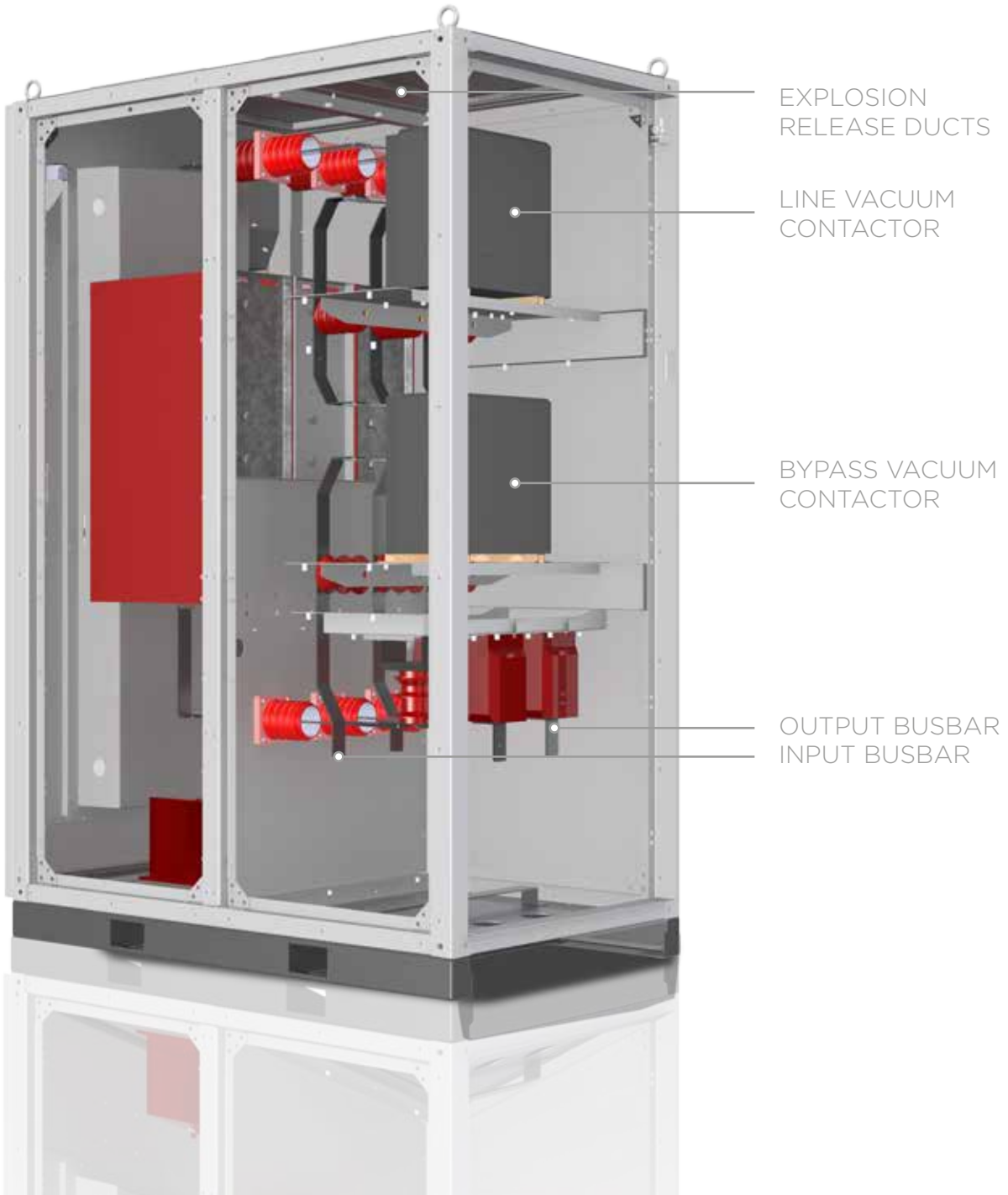



POWER ELECTRONICS
MEDIUM VOLTAGE SOFT STARTER



Maximum safety

The VS65 has been designed under the stringent IEC and EN standards and regulations, hence minimising the inherent risk of medium voltage equipment.



MAXIMUM SAFETY

- Independent sections isolate terminal strip and interface, from medium voltage equipment.
- Mechanic interlock or by procedure that avoid unexpected door opening that give access to live parts of the equipment.
- Optional input grounding switch that connects to ground each phase avoiding unexpected reconnections during maintenance.
- Pre start low voltage test by using a LV motor allows a safely fully functional performance test including: plant control integration, enabling bypass and line contactors, I/O settings and thyristor firing.
- Explosion proof cabinet resistant to internal shortcircuit. The energy generated is released through a dedicated duct on the top, therefore avoiding any personal injury.
- BIL rating up to 50kV for safety and reliability. Clearance and creepage distances oversizing offers maximum safety.
- Factory tested at full current and optionally specific witness testing available.
- Power Electronics personnel is present in every commissioning to get the most to your application.

MAXIMUM SAFETY AND
OUTSTANDING FEATURES
DESIGNED FOR THE MOST
DEMANDING INDUSTRY



Maximum motor care and soft starter protection



The VS65 soft starter includes built-in as standard the ultimate motor and soft starter protections, features that allow it to act as a motor protection relay.

STANDARD MOTOR AND SOFT STARTER PROTECTIONS

- Motor start delay
- Door open sensor
- Accelerating and decelerating control
- Starting to running transition
- SCRs over temperature
- Low input voltage
- Under-load protection
- Local and remote control selector
- Current imbalance
- Phase rotation
- Locked rotor / incomplete sequence
- i²t Electronic motor over load
- Instantaneous electronic over current trip / Shearpin
- Motor overcurrent
- Over voltage protection
- Input phase loss
- Controlled stopping ramp
- Starts per hour - Notching and jogging
- Communication loss
- Local emergency stop
- Line contactor
- Remote emergency stop
- Excessive start time (max. 120s)

OPTIONAL

- Input automatic circuit breaker, fuses, on-load disconnect or contactor
- Grounding switch
- Instantaneous ground fault detection
- Stator and bearing RTD protection
- Power factor protection
- Automatic circuit breaker, fuses and contactor status indicator
- Over and under frequency protection

REMOTE RTD SENSORS (OPTIONAL)

① STATOR WINDING 1	⑤ STATOR WINDING 5	⑨ APPLICATION BEARING 1
② STATOR WINDING 2	⑥ STATOR WINDING 6	⑩ APPLICATION BEARING 2
③ STATOR WINDING 3	⑦ MOTOR BEARING 1	⑪ CASE
④ STATOR WINDING 4	⑧ MOTOR BEARING 2	⑫ AMBIENT

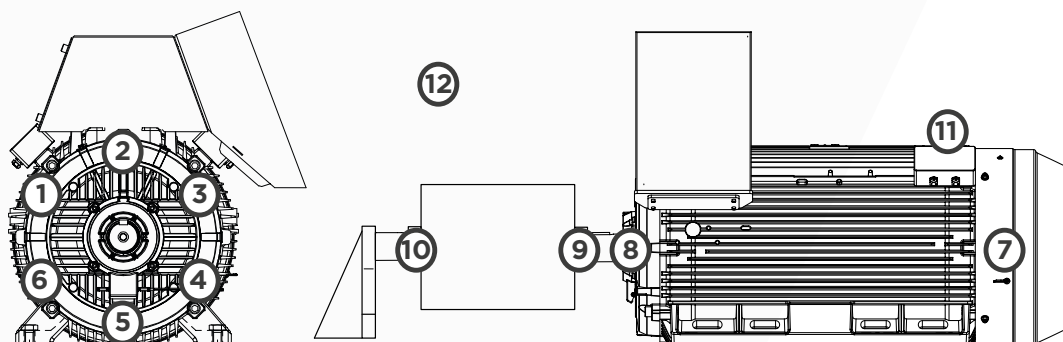

CONTINUOUS CURRENT AND
VOLTAGE MONITORING



Reliability

Our record in industrial technical service has set the boundaries to all of our designs in terms of reliability. Hence, we offer the most comprehensive and extended warranties of the market.



- Electronics conformally coated with military and aerospace technology (IEC61086-1:2004, -3-1) and totally sealed, allow to be installed in harsh environments.
- Heavy duty SCR design (125% continuous, 500% 5s and 50°C) and high inverse peak voltage without reactors (chokes).
- IP44 and optional IP54 degree of protection. No dust filters that is suitable for humid and polluted environments.
- EMC cabinet design to offer maximum immunity and minimum emissions.
- Line and bypass vacuum contactors isolate the power stage in running mode against mains disturbances.
- Copper busbars that can withstand from 40kA to 80kA short circuit currents.

Rated voltage	SCR pairs in series	SCRs Inverse Peak Voltage
2.3kV	1	6.500V
3.3kV/4.16kV	2	13.000V
5kV/5.5kV/6kV/6.6kV	3	18.000V
10kV	4	26.000V
11kV	5	32.500V
13.8kV	6	39.000V

TOTALLY SEALED
AND CONFORMALLY
COATED ELECTRONICS

Multiple features

A high investment in the development of control software has led to the most accurate, powerful and flexible performance.



The VS65 soft starter gets the most from your facilities, by implementing the unique dynamic torque control algorithm (CDP) that offers an ultimate break away torque and starts the most demanding applications. Some of the starting and stopping extended settings are:

STARTING MODES

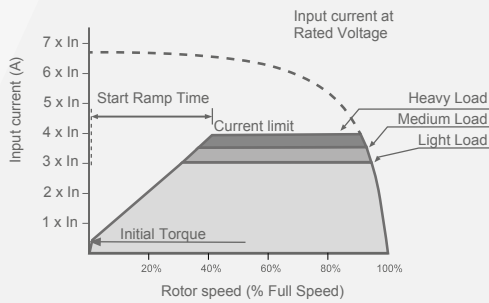

VOLTAGE RAMP

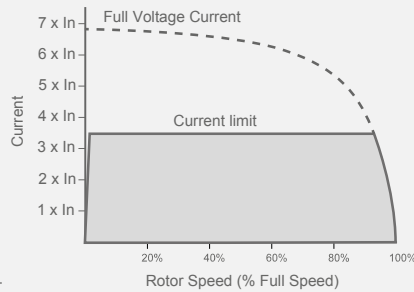

CURRENT LIMIT STARTING

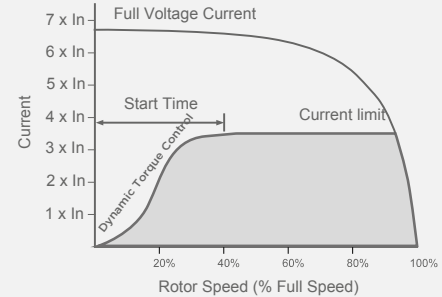

DYNAMIC TORQUE CONTROL

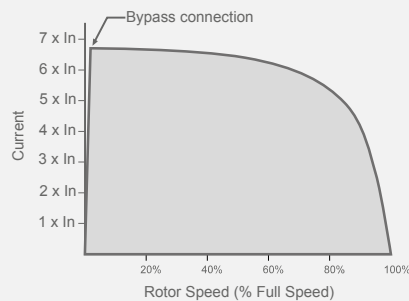

DIRECT STARTING

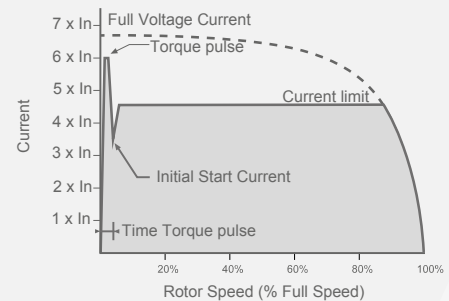

ROTOR LOCKED

STOP MODES

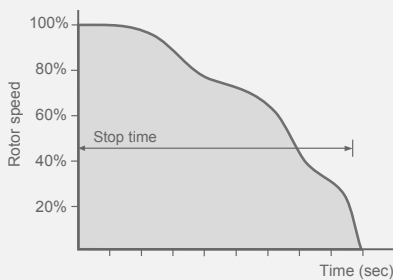

WATER HAMMER CONTROL

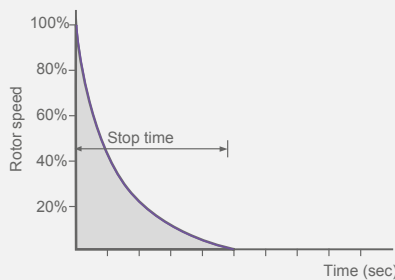

SPIN STOP

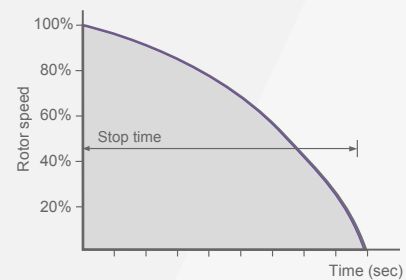

STOP WITH VOLTAGE RAMP

GET THE MOST OF YOUR APPLICATION WITH THE DUAL SETTING FUNCTION

The VS65 soft starter offers a double independent setting of the start and stop parameters, which permits the soft starter to shift performance according to the conditions: loaded or unloaded, raw material conditions, static pressure, temperature variations, blocked shaft, etc... the VS65 control allows the advanced users to adjust: torque pulse duration, break away torque and time, current limit, stop time, level and time of the overload and underload protections, i²t overload curve, n^o start per hour, minimum speed and water hammer control algorithm.



Intuitive control

The VS65 integrates an intuitive and dust resistant interface that includes backlit alphanumeric display with membrane key pad, status lights and pushbuttons that allow the user an easy operation and visualisation under the most demanding conditions.

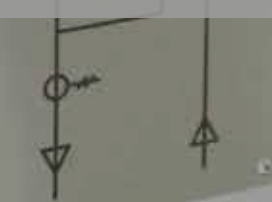



Local operation through display or pushbuttons, and remote operation through serial communication or I/O signals, can both be easily selected using the door mounted selector.

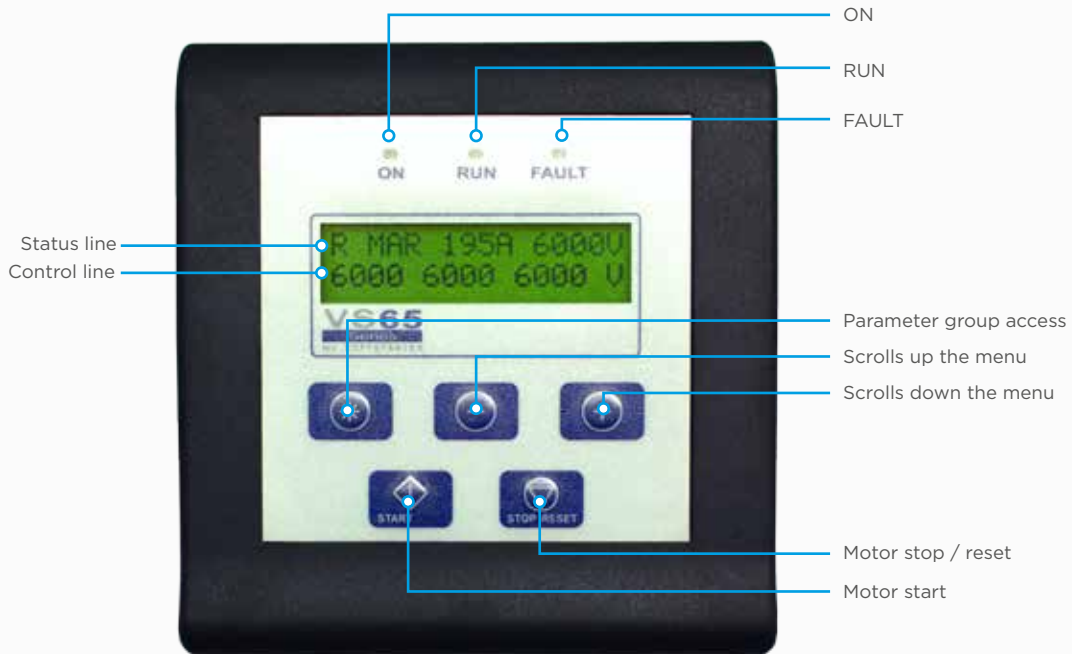

COMMUNICATIONS



Modbus-RTU over serial communication (RS232/RS485) built-in as standard, optionally communications gateways are available: Ethernet TCP/IP, Profibus-DP and DeviceNet.

PROFIPOWER: Modbus RTU (RS485) to Profibus-DP (9 Pin D-SUB/F). Communication speed máx. 12MB, Profibus cable recommended.

DEVICENET: Modbus RTU (RS485) to Devicenet (CAN) gateway. 31 nodes maximum. Asynchronous communication control mode. Half Duplex communication system, Transmission type: Bus method, Multi drop Link system. Communication speed: 125kbps, 250kbps, 500kbps, 1000 kbps. Transmission distance max. 500m. (125kbps Devicenet cable).

ETHERNET: Modbus RTU (RS485) to Modbus TCP (Ethernet). Communication system: Half Duplex, Full Duplex. CSMA/CD communication method. Communication speed: 10Mbps, 100Mbps.

VS65

TECHNICAL CHARACTERISTICS

INPUT	Input voltage ^[1]	2,3kVca, 3kVca-3.3kVca, 4.16kVca, 5kVac-5.5kVac, 6kVca-6.6kVac, 10kVca-11kVca, 13.8kVca ^[1]
	Input frequency	47 - 62Hz
	Control voltage ^[1]	230Vac ±10%, 50Hz / 110Vac ±10%, 50Hz
	Phase sequence	Compatible with any phase sequence
	Transitory over voltage protection	Snubber network / Optional Surge arresters
OUTPUT	Efficiency (full load)	> 99.6%, 100% Bypass activated
	Overload	125% of the continuous rated value 100% to 500% (during 1 - 60s configurable)
	Bypass contactor	Powerful enough to start the motor in direct start mode
ENVIRONMENTAL CONDITIONS	Protection degree	IP44, IP54 (optional)
	Cooling system	Natural
	Work temperature	0°C to +50°C
	Storage temperature	-25°C to +55°C
	Humidity	5% - 95%, non condensing
	Height ^[1]	1000m, no power derating
Painting ^[1]	RAL 7035, C4 corrosion (ISO 12944-2)	
INTERCONNECTION	Digital inputs	5 configurable input
	Analogue inputs	2 analogue inputs of 0-20mA or 4-20mA, 0-10V
	Output relays	3 switched relays (non-inductive 10A 250Vac)
	Analogue outputs	1 configurable output 0-20mA or 4-20mA
OPERATION MODES	Starting modes	Current limit starting
		Current ramp and current limit starting
		Dynamic torque control
		Direct starting
Stop modes	Initial torque pulse starting	
	Spin stop	
KEYPAD AND CONTROL PUSH BUTTONS	Display	Stop with voltage ramp
		Backlit, alphanumeric 2x16 characters
		5 keys: start, stop, access and scroll menu
	Door mounted indicators and buttons (soft starter)	Status leds: ON: Green. Turned on indicates there is voltage in the control boards. RUN: Orange. Flashing shows when the motor accelerates or decelerates. When turned on indicates the motor is working. FAULT: Red. Indicates fault.
		3 push buttons: Start, Stop and emergency stop
	Door mounted indicators and buttons (Optional Input module)	1 starting mode selector
		7 status pilots (running, stopped, ready, power supply, alarm, line contactor and bypass contactor)
	Display information	7 status pilots (Power supply L1/L2/L3, MV switches status on/off/loaded control voltage supply)
		3 push buttons: switch status, connection and disconnection
		1 selector of MV locking
Current of the three phases		
Line average voltage		
Digital inputs and relays status		
Analogue inputs and outputs status		
Power supply and motor frequency		
Power factor		
Motor torque and power		
Fault history (5 last faults)		
Total and partial starts number		
Total and partial operation hours		
Partial motor consumption (kWh)		

NOTES [1] Other configurations consult with Power Electronics.

COMMUNICATIONS	Standard Hardware	RS232 / RS485
	Optional Hardware	Ethernet / 9-Pin D-SUB/F
	Standard Protocol	Modbus-RTU
	Optional Protocol	Profibus DP, Devicenet, Ethernet, IEC 61850
	Control modes	Local: from keyboard and pushbuttons Remote: from the digital and analogic inputs. PLC: start / stop
STANDARD MOTOR PROTECTIONS ^[1]	Input phases sequence	
	High voltage	
	Input low voltage	
	Start current limit	
	Rotor locked	
	Motor overload (thermal model)	
	Under load	
	Unbalanced phases	
	Shearpin current	
	Maximum number of starts/hour	
	Other, consult Power Electronics	
SOFT STARTER PROTECTIONS	SCR overheat	
	Excessive start time (max 120s)	
	Input phase loss	
SOFT STARTER SETTINGS	Torque pulse	
	Initial torque	
	Initial torque time	
	Acceleration time	
	Current limit: 1to 5•In	
	Overload: 0.8 to 1.2•In, Overload curve: 0 to 10	
	Deceleration time / Spin stop	
	Slow Speed(1/7 fundamental frequency)	
	Dual setting	
	Number of Starts/hour allowed	
	Torque control	
Water hammer control		
REGULATIONS	Certification	CE
	Designed as	EMC Directive (2004/108/CE) EN61000-6-2, -4
	Design and construction	EN62271-1,-200
		EN60071-1,-2

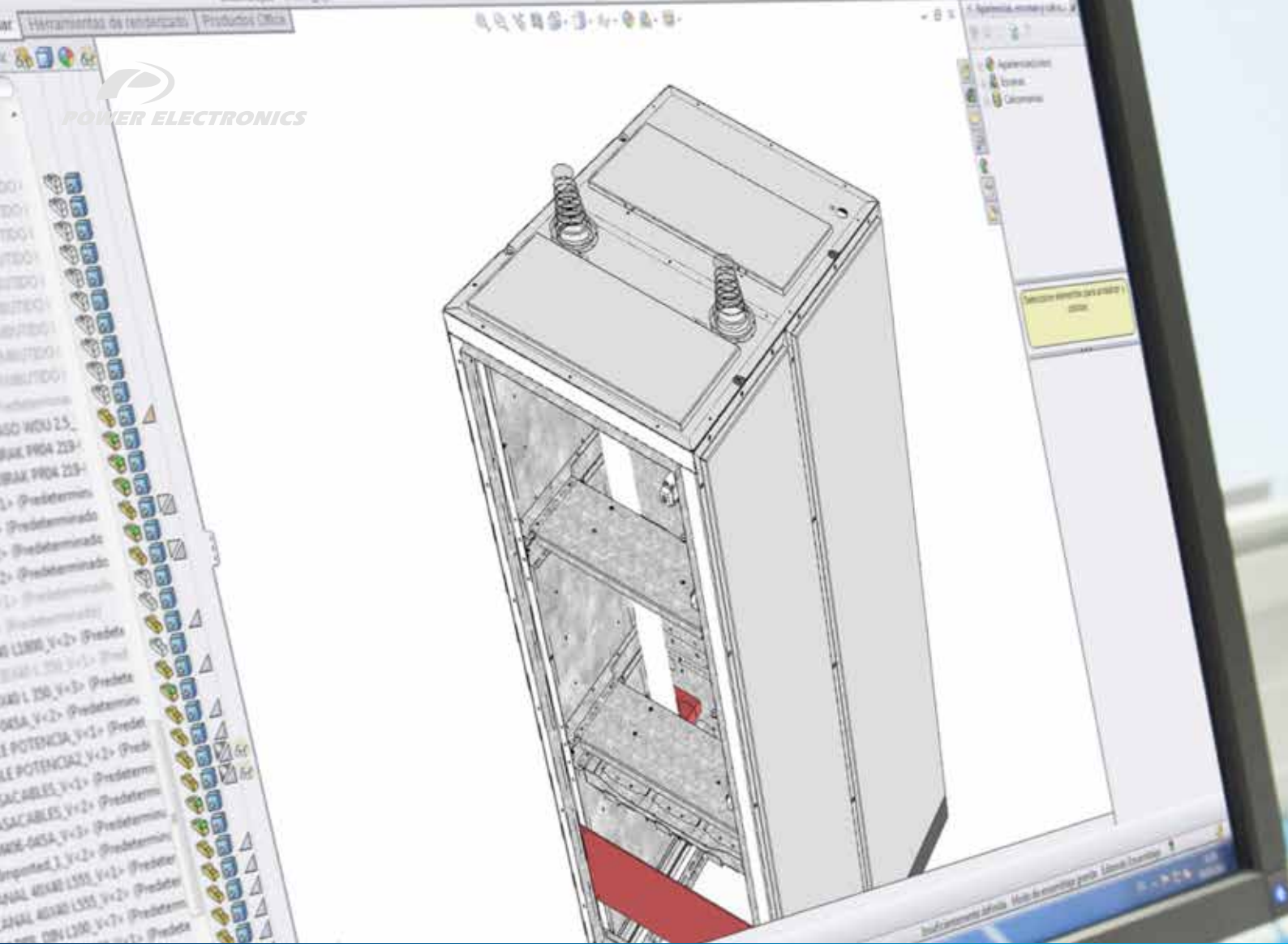

CUSTOMISED SOLUTIONS

High value medium voltage projects often require customer specific solutions. Our team of highly experienced engineers are available to modify our standard products to suit your specific demands to ensure you get the product you need.



• Reactive power compensation module:

- Medium Voltage Line Fuses
- Withdrawable vacuum contactors
- Current limit inductances
- Medium Voltage capacitor banks

Input protection module:

- Automatic Circuit Breaker (VCB)
- Medium Voltage Line Fuses
- Withdrawable vacuum contactors
- Earthing switch
- Commutation MV cabin
- Surge arresters
- Line switch with earthing

Customised control and pushbuttons:

- Selectors and pushbuttons
- Digital and analogue I/O pre-configuration
- Customised user terminal strip
- PTC and PT100 relays
- Instantaneous ground fault protection relay.
- Specific external Power Supply (UPS, 110Vac,...)
- Optional communication protocols (Profibus-DP, Dvicenet, Modbus TCP,...)
- Soft starter's and motor's heating resistor control.

Documentation:

- Electrical and dimensional drawings.
- ITP reports
- Witness factory Acceptance test (FAT)
-

Cabinet features:

- Special RAL, special labelling and warning labels.
- Incoming MV cable or busbar connection from top, right or backside.
- Lined up soft starters with common main input busbar and protection "Run busbar".

CONFIGURATION TABLE - VS65 SOFT STARTER MODULE

VS65	200		4		4		CL		0		-		-	
VS65 Series	Rated output current [1]		Rated input voltage		Degree of protection		Configuration		Power cable access		Fuses		Earth switch	
	200	200A	2	2300V	4	IP44	CL	Fixed line contactor / Fixed bypass contactor	O	Bottom input and output connection	-	Not Included	-	No Earth switch
	400	400A	3	3000V 3300V			CX	Withdrawable line contactor/ Fixed bypass contactor	T	Top input and bottom output connection	F	Included	S	ON/OFF/Earth switch
	4	4160V			XX	Withdrawable line contactor/ Withdrawable bypass contactor	U	Top input and output connection			E	With Earth switch
	600	600A	6	6000V 6600V										
			8	10000V 11000V										
			9	13200V 13800V										
			-	Under request										

NOTES [1] Check the rated current of the motor nameplate and indicate the short circuit current to guarantee the compatibility with the selected soft starter.
[2] Consult availability with Power Electronics.

Request your quote by filling the ordering info template; please consult Power Electronics with your additional demands.

DIMENSIONS - VS65 SOFT STARTER MODULE - UP TO 6.6kV

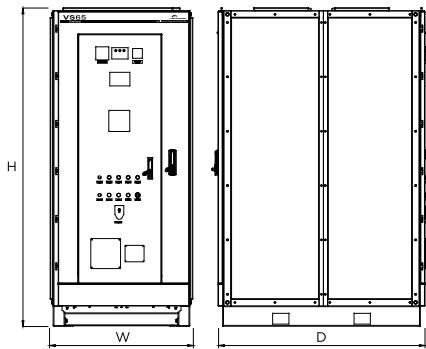

VS65				
VOLTAGE	CONFIGURATION	DIMENSIONS		
		WIDTH W (mm)	DEPTH D (mm)	HEIGHT H (mm)
<4.16kV	CL, CL_F, CL_S	1050	1550	2300
	CL_E, CL_FS, CL_FE	1050	1820	2300
5kV-6.6kV	CL, CL_F	1050	1550	2300
	CL_E, CL_S	1050	1820	2300

[1] Units I_n < 300A. Other voltages and configurations consult Power Electronics.

DIMENSIONS - VS65 SOFT STARTER MODULE - 13.8kV

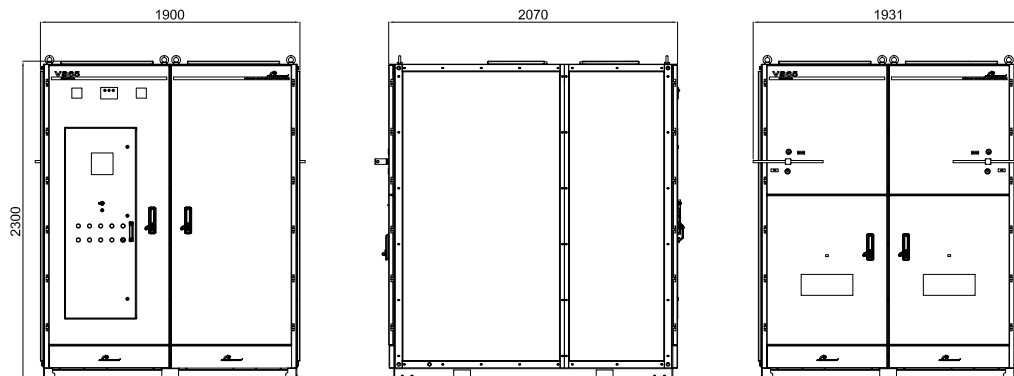

CONFIGURATION TABLE - PROTECTION MODULE VS65AR

VS65AR	1250		6		4		IA		T		-		-		
VS65 Protection module	Rated current ^[1]		Rated voltage		Degree of protection		Configuration		Acceso cables		Fusibles		Puesta a tierra		
	0400	400A	2	2300V	4	IP44	SF	Disconnecter with fuses	-	Entrada y salida inferior	-	No Incluido	-	Sin puesta a tierra	
	0630	630A	3	3000V 3300V			IA	Automatic Circuit Breaker (VCB)	T	Entrada superior y salida inferior	F	Incluido	E	Puesta a tierra	
	1250	1250A	4	4160V			IX	Withdrawable Automatic Circuit Breaker (VCB)	U	Entrada y salida superior				S	Seccionador ON/OFF/ Puesta a tierra
	6	6000V 6600V			CL	Fixed Line contactor						I	Seccionador ON/OFF/ Puesta a tierra ENTRADA y SALIDA
			8	10000V 11000V ^[2]			CX	Withdrawable Line contactor						M	Seccionador ON/OFF/ Puesta a tierra entrada y puesta a tierra salida
			9	13200V 13800V											
			-	Under request											

NOTAS [1] Compruebe la intensidad nominal de la placa de características del motor e indique la corriente de cortocircuito de la instalación para garantizar la compatibilidad de la celda de protección seleccionada.
[2] Consulte disponibilidad con Power Electronics.

Consulte a Power Electronics sus requerimientos particulares.

DIMENSIONS - PROTECTION MODULE VS65AR

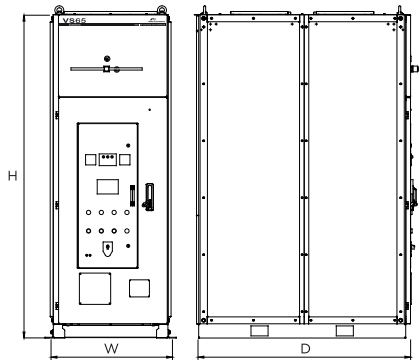

VS65AR			
CONFIGURATION	DIMENSIONS		
	WIDTH W (mm)	DEPTH D (mm)	HEIGHT H (mm)
IA / SF / CX / SE	850	1550	2300

STANDARD RATINGS - VS65 SOFT STARTER MODULE

VS65 2.3kV			
CODE	NOMINAL CURRENT (A)	MOTOR POWER	
		(kW)	(HP) ^[1]
VS65040 2	40	149	200
VS65050 2	50	186	250
VS65060 2	60	224	300
VS65070 2	70	261	350
VS65090 2	90	298	400
VS65100 2	100	336	450
VS65110 2	110	373	500
VS65130 2	130	447	600
VS65150 2	150	522	700
VS65170 2	170	597	800
VS65190 2	190	671	900
VS65210 2	210	746	1000
VS65270 2	270	932	1250
VS65320 2	320	1119	1500
VS65370 2	370	1305	1750
VS65420 2	420	1491	2000
VS65480 2	480	1678	2250
VS65530 2	530	1864	2500
VS65590 2	590	2051	2750

[1] HP standard motor rated power (cos ϕ = 0.88, 2.3kV)

VS65 3kV-3.3kV			
CODE	NOMINAL CURRENT (A)	MOTOR POWER	
		(kW) ^[2]	(HP)
VS65040 3	40	200	268
VS65050 3	50	250	335
VS65060 3	60	315	422
VS65070 3	70	355	476
VS65080 3	80	400	536
VS65090 3	90	450	603
VS65100 3	100	500	670
VS65110 3	110	560	751
VS65120 3	120	630	845
VS65140 3	140	710	952
VS65160 3	160	800	1073
VS65180 3	180	900	1207
VS65200 3	200	1000	1341
VS65250 3	250	1250	1676
VS65280 3	280	1400	1877
VS65320 3	320	1600	2145
VS65360 3	360	1800	2413
VS65400 3	400	2000	2681
VS65450 3	450	2240	3003
VS65500 3	500	2500	3352
VS65560 3	560	2800	3754

[2] kW standard motor rated power (cos ϕ = 0.88, 3.3kV)

VS65 4.16kV			
CODE	NOMINAL CURRENT (A)	MOTOR POWER	
		(kW)	(HP) ^[3]
VS65050 4	50	298	400
VS65055 4	55	336	450
VS65060 4	60	373	500
VS65070 4	70	447	600
VS65080 4	80	522	700
VS65095 4	95	597	800
VS65110 4	110	671	900
VS65120 4	120	746	1000
VS65150 4	150	932	1250
VS65180 4	180	1119	1500
VS65210 4	210	1305	1750
VS65240 4	240	1491	2000
VS65270 4	270	1678	2250
VS65300 4	300	1864	2500
VS65320 4	320	2051	2750
VS65350 4	350	2237	3000
VS65410 4	410	2610	3500
VS65470 4	470	2983	4000
VS65530 4	530	3356	4500
VS65590 4	590	3728	5000

[3] HP standard motor rated power (cos ϕ = 0.88, 4.16kV)

VS65 5-5.5kV			
CODE	NOMINAL CURRENT (A)	MOTOR POWER	
		(kW) ^[4]	(HP)
VS65050 5	50	400	536
VS65055 5	55	450	603
VS65060 5	60	500	671
VS65065 5	65	560	751
VS65075 5	75	630	845
VS65085 5	85	710	952
VS65095 5	95	800	1073
VS65110 5	110	900	1207
VS65120 5	120	1000	1341
VS65150 5	150	1250	1676
VS65170 5	170	1400	1877
VS65190 5	190	1600	2146
VS65220 5	220	1800	2414
VS65240 5	240	2000	2682
VS65270 5	270	2240	3004
VS65300 5	300	2500	3353
VS65330 5	330	2800	3755
VS65380 5	380	3150	4224
VS65420 5	420	3550	4761
VS65480 5	480	4000	5364
VS65540 5	540	4500	6035
VS65600 5	600	5000	6705

[4] kW standard motor rated power (cos ϕ = 0.88, 5.5kV)

VS65 6kV - 6.6kV			
CODE	NOMINAL CURRENT (A)	MOTOR POWER	
		(kW) ^[5]	(HP)
VS65040 6	40	400	536
VS65045 6	45	450	603
VS65050 6	50	500	671
VS65055 6	55	560	751
VS65060 6	60	630	845
VS65070 6	70	710	952
VS65080 6	80	800	1073
VS65090 6	90	900	1207
VS65100 6	100	1000	1341
VS65125 6	125	1250	1676
VS65140 6	140	1400	1877
VS65160 6	160	1600	2146
VS65180 6	180	1800	2414
VS65200 6	200	2000	2682
VS65220 6	220	2240	3004
VS65250 6	250	2500	3353
VS65280 6	280	2800	3755
VS65300 6	300	3150	4224
VS65350 6	350	3550	4761
VS65400 6	400	4000	5364
VS65450 6	450	4500	6035
VS65500 6	500	5000	6705
VS65560 6	560	5600	7510

[5] kW standard motor rated power (cos ϕ = 0.88, 6.6kV)

VS65 10kV - 11kV			
CODE	NOMINAL CURRENT (A)	MOTOR POWER	
		(kW) ^[6]	(HP)
VS65020 8	20	355	476
VS65025 8	25	400	536
VS65030 8	30	500	671
VS65035 8	35	630	845
VS65040 8	40	710	952
VS65050 8	50	800	1073
VS65055 8	55	900	1207
VS65060 8	60	1000	1341
VS65075 8	75	1250	1676
VS65085 8	85	1400	1877
VS65095 8	95	1600	2146
VS65110 8	110	1800	2414
VS65120 8	120	2000	2682
VS65135 8	135	2240	3004
VS65150 8	150	2500	3353
VS65170 8	170	2800	3755
VS65190 8	190	3150	4224
VS65210 8	210	3550	4761
VS65240 8	240	4000	5364
VS65270 8	270	4500	6035
VS65300 8	300	5000	6705
VS65340 8	340	5600	7510
VS65380 8	380	6300	8449

[6] kW standard motor rated power (cos ϕ = 0.88, 11kV)

VS65 13.8kV - NEMA			
CODE	NOMINAL CURRENT (A)	MOTOR POWER	
		(kW) ^[7]	(HP)
XMV66040 138	40	746	1000
XMV66050 138	50	932	1250
XMV66060 138	60	1119	1500
XMV66070 138	70	1305	1750
XMV66080 138	80	1491	2000
XMV66090 138	90	1678	2250
XMV66100 138	100	1864	2500
XMV66120 138	120	2237	3000
XMV66140 138	140	2610	3500
XMV66160 138	160	2983	4000
XMV66180 138	180	3356	4500
XMV66200 138	200	3728	5000
XMV66220 138	220	4101	5500
XMV66240 138	240	4474	6000
XMV66270 138	270 ^[8]	5220	7000
XMV66310 138	310 ^[8]	5966	8000

[7] kW standard motor rated power (cos ϕ = 0.8, 13.8kV).

[8] Overload capacity limited.

NOTES

Request your quote by filling the Ordering info template; please consult Power Electronics with your additional demands.

Soft starters over 400A and 7.2kV will be equipped with automatic circuit breaker instead of vacuum contactors and engineered under request, consult availability.