



AC10 series

IP20 0-180kW

HA502320U001 Issue 6
Product Manual

aerospace
climate control
electromechanical
filtration
fluid & gas handling
hydraulics
pneumatics
process control
sealing & shielding



ENGINEERING **YOUR** SUCCESS.



AC10 series

IP20 0 – 180kW

Product Manual

HA502320U001 Issue 6

2016 Parker Hannifin Manufacturing Ltd.

All rights strictly reserved. No part of this document may be stored in a retrieval system, or transmitted in any form or by any means to persons not employed by a Parker SSD Drives company without written permission from Parker SSD Drives, a division of Parker Hannifin Ltd. Although every effort has been taken to ensure the accuracy of this document it may be necessary, without notice, to make amendments or correct omissions. Parker SSD Drives cannot accept responsibility for damage, injury, or expenses resulting therefrom.

WARRANTY

The general terms and conditions of sale of goods and/or services of Parker Hannifin Europe Sarl, Luxembourg, Switzerland Branch, Etoy, apply to this product unless otherwise agreed. The terms and conditions are available on our website www.parker.com/terms and conditions/Switzerland

**FAILURE OR IMPROPER SELECTION OR IMPROPER USE OF
THE PRODUCTS DESCRIBED HEREIN OR RELATED ITEMS
CAN CAUSE DEATH, PERSONAL INJURY AND PROPERTY
DAMAGE.**

This document and other information from Parker-Hannifin Corporation, its subsidiaries and authorized distributors provide product or system options for further investigation by users having technical expertise.

The user, through its own analysis and testing, is solely responsible for making the final selection of the system and components and assuring that all performance, endurance, maintenance, safety and warning requirements of the application are met. The user must analyze all aspects of the application, follow applicable industry standards, and follow the information concerning the product in the current product catalog and in any other materials provided from Parker or its subsidiaries or authorized distributors.

To the extent that Parker or its subsidiaries or authorized distributors provide component or system options based upon data or specifications provided by the user, the user is responsible for determining that such data and specifications are suitable and sufficient for all applications and reasonably foreseeable uses of the components or systems.

Safety

Safety Information



Requirements

IMPORTANT: *Please read this information BEFORE installing and operating the equipment.*

Intended Users

This manual is to be made available to all persons who are required to install, configure or service equipment described herein, or any other associated operation.

The information given is intended to highlight safety issues, EMC considerations, and to enable the user to obtain maximum benefit from the equipment.

Complete the following table for future reference detailing how the unit is to be installed and used.

INSTALLATION DETAILS	
Model Number <i>(see product label)</i>	
Where installed <i>(for your own information)</i>	
Unit used as a: <i>(refer to Certification for the Inverter)</i>	<input type="checkbox"/> Component <input type="checkbox"/> Relevant Apparatus
Unit fitted:	<input type="checkbox"/> Wall-mounted <input type="checkbox"/> Enclosure

Applications

The equipment described is intended for industrial motor speed control utilizing AC induction motors.

Personnel

Installation, operation and maintenance of the equipment should be carried out by competent personnel. A competent person is someone who is technically qualified and familiar with all safety information and established safety practices; with the installation process, operation and maintenance of this equipment; and with all the hazards involved.

Product Warnings

	<p>DANGER</p> <p>Risk of electric shock</p>		<p>WARNING</p> <p>Hot surfaces</p>		<p>CAUTION</p> <p>Refer to documentation</p>		<p>EARTH/GROUND</p> <p>Protective Conductor Terminal</p>
--	--	--	---	--	---	--	---

Hazards

DANGER! - Ignoring the following may result in injury

1. This equipment can endanger life by exposure to rotating machinery and high voltages.
2. The equipment must be permanently earthed due to the high earth leakage current, and the drive motor must be connected to an appropriate safety earth.
3. Ensure all incoming supplies are isolated before working on the equipment. Be aware that there may be more than one supply connection to the drive.
4. There may still be dangerous voltages present at power terminals (motor output, supply input phases, DC bus and the brake, where fitted) when the motor is at standstill or is stopped.
5. For measurements use only a meter to IEC 61010 (CAT III or higher). Always begin using the highest range. CAT I and CAT II meters must not be used on this product.
6. Allow at least 5 minutes (20 minutes for above 30kW) for the drive's capacitors to discharge to safe voltage levels (less than 50V). Use the specified meter capable of measuring up to 1000V DC & AC RMS to confirm that less than 50V is present between all power terminals and ground.
7. Unless otherwise stated, this product must NOT be dismantled. There are no user-serviceable components. In the event of a fault, the drive must be returned to Parker. You will need Return Material Authorization from your local distributor.

WARNING! - Ignoring the following may result in injury or damage to equipment

SAFETY

Where there is conflict between EMC and Safety requirements, personnel safety shall always take precedence.

- Never perform high voltage resistance checks on the wiring without first disconnecting the drive from the circuit being tested.
- Ensuring ventilation is sufficient, provide guarding and /or additional safety systems to prevent injury or damage to equipment.
- When replacing a drive in an application and before returning to use, it is essential that all user defined parameters for the product's operation are correctly installed.
- The AC10 series is not a safety component or safety related product.
- All control and signal terminals are SELV, i.e. protected by double insulation. Ensure all external wiring is rated for the highest system voltage.
- Thermal sensors contained within the motor must have at least basic insulation.
- All exposed metalwork in the Inverter is protected by basic insulation and bonded to a safety ground.
- RCDs are not recommended for use with this product but, where their use is mandatory, only Type B RCDs should be used.

EMC

- In a domestic environment this product may cause radio interference in which case supplementary mitigation measures may be required.
- This equipment contains electrostatic discharge (ESD) sensitive parts. Observe static control precautions when handling, installing and servicing this product.
- This is a product of the restricted sales distribution class according to IEC 61800-3. It is designated as "professional equipment" as defined in EN61000-3-2. Permission of the supply authority shall be obtained before connection to the low voltage supply.

CAUTION!**APPLICATION RISK**

- The specifications, processes and circuitry described herein are for guidance only and may need to be adapted to the user's specific application. We can not guarantee the suitability of the equipment described in this Manual for individual applications.
-

RISK ASSESSMENT

Under fault conditions, power loss, or unintended operating conditions, the inverter may not operate as intended. In particular:

- Stored energy might not discharge to safe levels as quickly as suggested, and can still be present even though the inverter appears to be switched off.
- The motor's direction of rotation might not be controlled
- The motor speed might not be controlled
- The motor might be energized

An inverter is a component within a drive system that may influence its operation or effects under a fault condition. Consideration must be given to:

- Stored energy
- Supply disconnects
- Sequencing logic
- Unintended operation

Contents

	<i>Page</i>
Chapter 1 Introduction	1-1
1.1 Understanding the Product Code	1-1
1.2 Nameplate Example	1-1
1.3 Product Range	1-2
Chapter 2 Product Overview	2-1
2.1 Designed Standards for Implementation	2-1
2.2 Control Features	2-2
Chapter 3 Installation	3-1
3.1 Equipment Precautions	3-1
3.2 Minimum Air Clearance	3-2
3.3 Inverters Installed in a Control Cabinet	3-3
Chapter 4 Maintenance	4-1
4.1 Periodic Checking	4-1
4.2 Storage	4-1
4.3 Daily Maintenance	4-1
4.4 Returning the Unit to Parker SSD Drives	4-1
Chapter 5 The Keypad	5-1
5.1 The Display	5-1
5.2 Remote-control	5-1
5.2.1 Panel Mounting Dimensions	5-2
5.2.1 Port of control panel	5-2
Chapter 6 The Menu Structure	6-1
6.1 Parameters Setting	6-1
6.1.1 Function Codes Switchover in/between Code-Groups	6-2
6.1.2 Panel Display	6-3
Chapter 7 Installation & Connection	7-1
7.1 Installation	7-1
7.2 Connection	7-3
7.2.1 Power Terminals	7-4
7.2.2 Control Terminals	7-4
7.3 Measurement of Main Circuit Voltages, Currents and Powers	7-5
7.4 Functions of Control Terminals	7-7
7.5 Wiring for Digital Input Terminals:	7-8
7.5.1 Wiring for positive source electrode (NPN mode)	7-8
7.5.2 Wiring for active source electrode	7-8
7.5.3 Wiring for positive Sink electrode (PNP mode) -- Switch J7 set for PNP. 7-9	
7.5.4 Wiring for active drain electrode (PNP mode) (Common Collector Mode) 7-9	
7.6 Connection Overview	7-10
7.6.1 Terminal Tightening Torques	7-11
7.7 Basic Methods of Suppressing the Noise	7-12
7.7.1 Noise propagation paths and suppressing methods	7-12

Contents

	<i>Page</i>
7.7.2 Basic methods of suppressing the noise.....	7-13
7.7.3 Field Wire Connections	7-14
7.7.4 Grounding.....	7-14
7.7.5 Leakage Current.....	7-15
7.7.6 Electrical Installation of the Drive	7-15
7.7.7 Application of Power Line Filter	7-16
Chapter 8 Operation and Simple Running.....	8-1
8.1 Basic Conception	8-1
Control Mode.....	8-1
Mode of Torque Compensation	8-1
Mode of frequency setting.....	8-1
Mode of controlling for running command.....	8-1
Operating status of inverter	8-1
8.2 Keypad Panel and Operation Method	8-2
8.2.1 Method of operating the keypad panel.....	8-2
8.2.2 Operation Process of Setting the Parameters using the Keypad Panel.....	8-2
8.2.3 Setting the Parameters	8-2
8.2.4 Switching and displaying of status parameters.....	8-2
8.2.5 Switching of the parameters displayed under stopped status	8-2
8.2.6 Switching of the parameters displayed under running status	8-3
8.2.7 Operation process of measuring motor parameters	8-3
Operation process of simple running	8-4
8.3 Illustration of Basic Operation	8-5
Frequency setting, start, forward running and stop using the keypad panel.....	8-5
8.3.2 Setting the frequency using the keypad panel, and starting, forward and reverse running, and stopping inverter through control terminals.....	8-6
8.3.3 Operation process of jogging operation using the keypad panel	8-6
8.3.4 Setting the frequency with analog terminal and controlling the operation with control terminals	8-7
Chapter 9 Function Parameters	9-1
9.1 Basic Parameters	9-1
9.2 Operation Control	9-10
9.3 Multifunctional Input and Output Terminals	9-17
9.3.1 Digital multifunctional output terminals	9-17
9.3.2 Digital multifunctional input terminals.....	9-20
9.3.3 Analog input monitoring.....	9-25
9.4 Analog Input and Output	9-25
9.5 Multi-stage Speed Control.....	9-29
9.6 Auxiliary Functions	9-32
9.7 Malfunction and Protection.....	9-36

Contents

	<i>Page</i>
9.8 Motor Parameters.....	9-40
9.9 Communication Parameter	9-43
9.10 PID Parameters.....	9-43
9.11 Torque control parameters.....	9-47
Chapter 10 Troubleshooting	10-1
Chapter 11 Technical Specifications.....	11-1
11.1 Selection of Braking Resistance.....	11-1
Chapter 12 Modbus Communication	12-1
12.1 General.....	12-1
12.2 Modbus Protocol	12-1
12.2.1 Transmission mode	12-1
12.2.2 ASCII Mode (F901=1)	12-1
12.2.3 RTU Mode (F901=2)	12-1
12.3 Baud rate F904.....	12-1
12.4 Frame structure:	12-2
12.5 Error Check	12-2
12.5.1 ASCII mode.....	12-2
12.5.2 RTU Mode.....	12-2
12.5.3 Protocol Converter	12-3
12.6 Command Type & Format	12-3
12.6.1 Address and meaning	12-3
12.6.2 Running Status Parameters.....	12-4
12.6.3 Control commands	12-5
12.6.4 Illegal Response When Reading Parameters	12-6
12.7 Function Codes Related to Communication	12-7
12.8 Physical Interface	12-8
12.8.1 Interface instruction	12-8
12.8.2 Structure of Field Bus	12-8
12.9 Grounding and Terminal	12-8
12.9.1 Examples	12-9
Chapter 13 The Default Applications	13-1
13.1 Application 1: Basic Speed Control (F228 = 1).....	13-2
13.2 Application 2 : Auto/Manual Control (F228 = 2)	13-4
13.3 Application 3: Preset Speeds (F228 = 3)	13-6
13.4 Application 4 : Raise/Lower Secondary (F228 = 4)	13-8
13.5 Application 5: PID (F228 = 5).....	13-10
Chapter 14 Compliance	14-1
14.1 Applicable Standards.....	14-1
14.2 European Compliance	14-2
14.2.1 Low Voltage Directive.....	14-2
14.2.2 EMC Directive	14-2
14.2.3 Machinery Directive.....	14-2

Contents

	<i>Page</i>
14.2.4 EMC Compliance	14-2
14.3 EMC Standards Comparison	14-3
14.3.1 Radiated.....	14-3
14.4 North American & Canadian Compliance Information (Frame 1 – 5 ONLY) 14-5	
14.4.1 UL Standards.....	14-5
14.4.2 UL Standards Compliance.....	14-5
DECLARATION OF CONFORMITY.....	14-10
Chapter 15 Parameter Reference	15-1
Basic parameters: F100-F160.....	15-1
Running control mode: F200-F230	15-4
Multifunctional Input and Output Terminals: F300-F330	15-6
Analog Input and Output: F400-F480.....	15-9
Multi-stage Speed Control: F500-F580	15-11
Auxiliary Functions: F600-F670	15-12
Timing Control and Protection: F700-F770	15-13
Motor parameters: F800-F830	15-15
PID parameters: FA00-FA80	15-17
Torque control parameters: FC00-FC40	15-18

Chapter 1 Introduction

This manual offers an introduction to the installation and connection for the AC10 series. Parameters setting, software and operation are also covered in this manual.

1.1 Understanding the Product Code

Model Number

The unit is fully identified using a four block alphanumeric code which records how the drive was calibrated, and its various settings when dispatched from the factory. This can also be referred to as the Product Code.

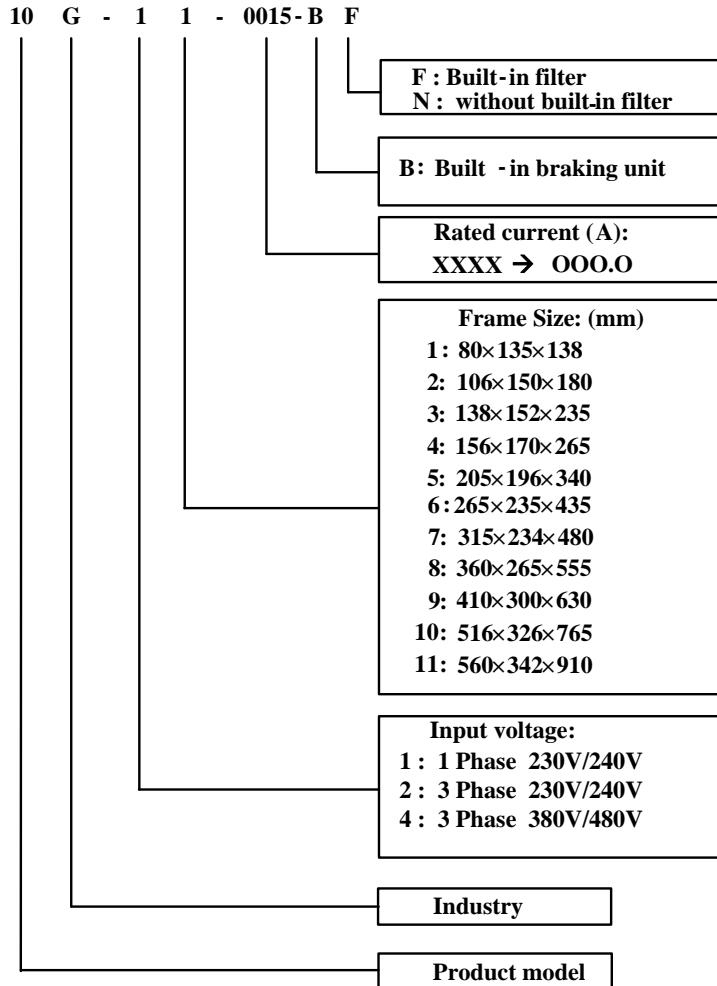

1.2 Nameplate Example

This example nameplate shows the product as an AC10 series IP20 2.2kW inverter with 3-phase input.

3Ph: three-phase input; 380-480V, 50/60Hz: input voltage range and rated frequency.

3Ph: 3-phase output; 6.5A, 2.2kW: rated output current and power;

		Parker Hannifin Corporation www.parker.com			
MODEL	10G - 42 - 0065 - BF				
INPUT	3 PH	AC	380~480 V	7.5/7.0 A	50/60 Hz
OUTPUT	3 PH	0~INPUT V		6.5 A	2.2 kW
	0~590 Hz				
					SW NO. 2.10 BS NO. 1.01
POWER CONVERSION EQUIPMENT SDR6 IP20 E142140					Made In China

1-2 Introduction

1.3 Product Range

Supply	Part Number	kW	Input Current (A)			Output Current (A)	Input protection current
			230V	380V/400V	460V/480V		
1Ph 230V	10G-11-0015-XX	0.2	4			1.5	6.0
	10G-11-0025-XX	0.37	5.8			2.5	10.0
	10G-11-0035-XX	0.55	7.6			3.5	14.0
	10G-11-0045-XX	0.75	10			4.5	18.1
	10G-12-0050-XX	1.1	10.8			5	24.5
	10G-12-0070-XX	1.5	14			7	25.2
	10G-12-0100-XX	2.2	20			10	32.0
3Ph 230V	10G-31-0015-XX	0.2	2.5			1.5	5.0
	10G-31-0025-XX	0.37	3.5			2.5	8.2
	10G-31-0035-XX	0.55	4.5			3.5	10.0
	10G-31-0045-XX	0.75	5.4			4.5	11.5
	10G-32-0050-XX	1.1	5.8			5	18.0
	10G-32-0070-XX	1.5	7.8			7	18.2
	10G-32-0100-XX	2.2	11			10	21.5
	10G-33-0170-XX	4	18.5			17	28
	10G-34-0210-XX	5.5	22			21	33
	10G-35-0300-XX	7.5	31			30	47
	10G-35-0400-XX	11	41			40	62
	10G-36-0550-XX	15	57			55	86
3Ph 400V	10G-41-0006-XX	0.2		1.1	0.8	0.6	2.5
	10G-41-0010-XX	0.37		1.5	1.2	1	5.0
	10G-41-0015-XX	0.55		2.1	1.8	1.5	5.5
	10G-42-0020-XX	0.75		3	2.1	2	6.5
	10G-42-0030-XX	1.1		4	3.2	3	10.2
	10G-42-0040-XX	1.5		5	4.2	4	11.0
	10G-42-0065-XX	2.2		7.5	7.0	6.5	15.0
	10G-43-0080-XX	3.7		10.5	8.3	8	18.0
	10G-43-0090-XX	4		11	9.2	9	21.0
	10G-43-0120-XX	5.5		14	11.5	12	29.0
	10G-44-0170-XX	7.5		18.5	16	17	34.0
	10G-44-0230-XX	11		24	21	23	46.5
	10G-45-0320-XX	15		36.5	27	32	80.0
	10G-45-0380-XX	18.5		44	31	38	90
	10G-45-0440-XX	22		51	35	44	100
	10G-46-0600-XX	30		70	53	60	110
	10G-47-0750-XX	37		80	64	75	120
	10G-47-0900-XX	45		94	75	90	150
	10G-48-1100-XX	55		120	85	110	180
	10G-48-1500-XX	75		160	115	150	240
10G-49-1800-XX	90		190	130	180	285	
10G-49-2200-XX	110		225	170	220	340	
10G-410-2650-XX	132		275	210	265	400	
10G-411-3200-XX	160		330	250	320	500	
10G-411-3600-XX	180		370	280	360	550	

Chapter 2 Product Overview

The external structure of AC10 series inverter has a plastic housing, up to Frame 5.

Illustrated is the AC10G-12-0050-XX

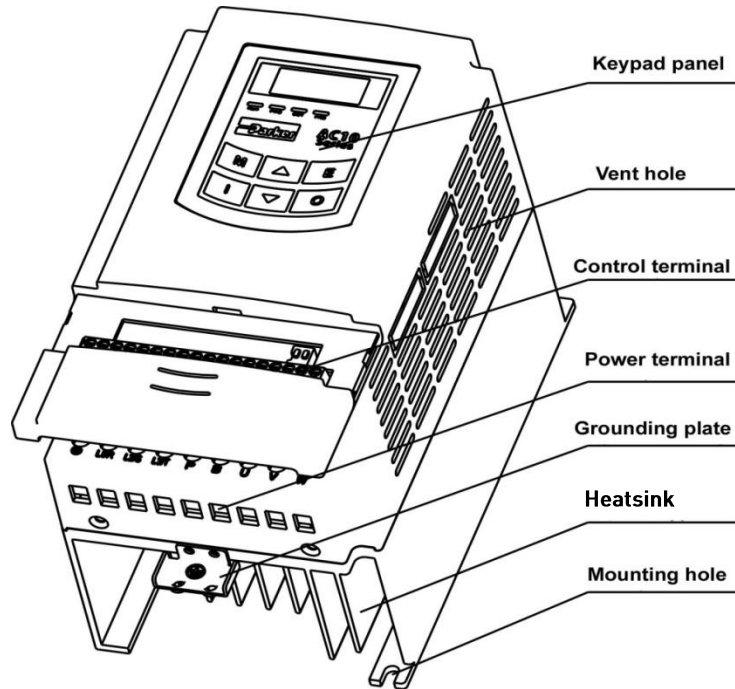

Metal housing (frame sizes 6-11) uses advanced exterior plastic-spraying and powder-coating process on the surface with colour and detachable one-side door hinge structure adopted for the front cover, convenient for wiring and maintenance. Taking 10G-46-0060 for instance, its appearance and structure are shown below.

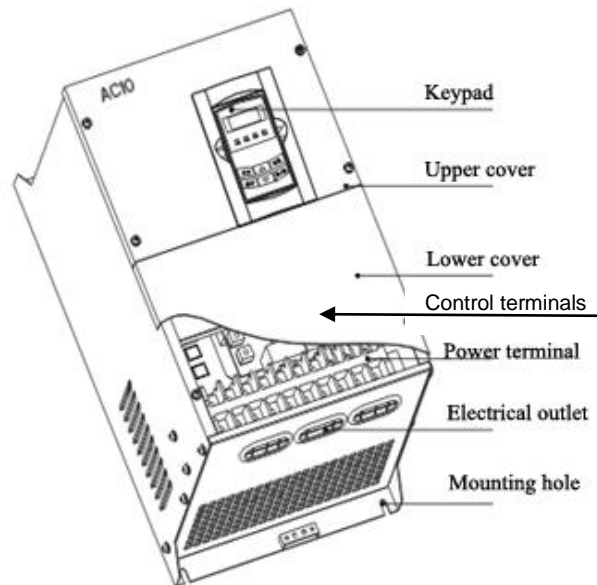

2.1 Designed Standards for Implementation

IEC/EN 61800-5-1: 2007 Adjustable speed electrical power drive systems safety requirements.

IEC/EN 61800-3: 2004 Adjustable speed electrical power drive systems-Part 3: EMC product standard including specific test methods.

IEC 529(1989)/EN60529 Degrees of protection provided by enclosure (IP code)

2.2 Control Features

Table 2-1 Technical Specification for AC10 series Inverters

Input	Rated Voltage Range	3-phase 380-480V (+10%, -15%) 1-phase 220-240V (±15%) 3-phase 220-240V (±15%)
	Rated Frequency	50/60Hz
Output	Rated Voltage Range	3-phase 0-INPUT (V)
	Frequency Range	0.50~590.0Hz
Control Mode	Carrier Frequency	800~10000Hz; Fixed carrier-wave and random carrier-wave can be selected by F159.
	Input Frequency Resolution	Digital setting: 0.01Hz, analog setting: max frequency × 0.1%
	Control Mode	Sensorless vector control (SVC), V/Hz control
	Start Torque	0.5 Hz / 150% (SVC)
	Speed-control Scope	1:100 (SVC)
	Steady Speed Precision	±0.5% (SVC)
	Torque Control Precision	±5% (SVC)
	Overload Capacity	150% rated current, 60 seconds.
	Torque Elevating	Auto torque promotion, manual torque promotion includes 1-20 curves.
	V/Hz Curve	3 kinds of modes: quadratic type, square type and user-defined V/Hz curve.
	DC Braking	DC braking frequency: 0.2-5.00 Hz, braking time: 0.00~30.00s
	Jogging Control	Jogging frequency range: min frequency~ max frequency, jogging acceleration/deceleration time: 0.1~3000.0s
	Operation Function	Auto Circulating Running and multi-stage speed running
Built-in PID adjusting		Easy to realize a system for process closed-loop control
Auto voltage regulation (AVR)		When source voltage changes, the modulation rate can be adjusted automatically, so that the output voltage is unchanged.
Frequency Setting		Analog signal (0~5V, 0~10V, 0~20mA); keypad (terminal)▲ / ▼ keys, external control logic and automatic circulation setting.
Start/Stop Control		Terminal control, keypad control or communication control.
Optional	Running Command Channels	3 kinds of channels from keypad panel, control terminals or RS485
	Frequency Source	Frequency sources: User terminals, from the MMI (Man-Machine Interface) or via RS485.
	Auxiliary frequency Source	5 options
Protection Function	Built-in EMC filter, built-in braking unit	
MMI Display	Input phase loss, Output phase loss, input under-voltage, DC over-voltage, over-current, inverter over-load, motor over-load, current stall, over-heat, external disturbance, analog line disconnected.	
Environment Conditions	LED seven segment display showing output frequency, rotate-speed (rpm), output current, output voltage, DC bus voltage, PID feedback value, PID setting value, linear-velocity, types of faults, and parameters for the system and operation; LED indicators showing the current working status of inverter.	
	Equipment Location	In an indoor location, Prevent exposure from direct sunlight, from dust, from caustic gases, flammable gases, steam or other contamination.
	Environment Temperature	-10°C ~ +40°C (50°C with derating)
	Environment Humidity	Below 90% (non condensing)
	Vibration Strength	Below 0.5g
	Height above sea level	1000m or below (3000m with derating)
Protection level	Environment 3C3 conformance	
Applicable Motor	IP20	
	0.2~180kW	

Chapter 3 Installation

IMPORTANT Read Chapter 14 “Compliance” before installing this unit.

3.1 Equipment Precautions

- Check for signs of transit damage.
- Check the product code on the rating label conforms to your requirements.
- Installation and application environment should be free of rain, drips, steam, dust and oily dirt; without corrosive or flammable gases or liquids, metal particles or metal powder. Environment temperature within the scope of $-10^{\circ}\text{C} \sim +50^{\circ}\text{C}$ (40°C without derating)
- Ensure inverter is installed away from combustibles.
- Do not drop anything into the inverter.
- The reliability of inverters relies heavily on the temperature. As the surrounding temperature increases by 10 degrees the inverter life will be halved.
- The inverter is designed to be installed in a control cabinet. The inverter should be mounted to allow free air flow. The inverter should be installed vertically on a solid, flat, vertical surface. If there are several inverters in one cabinet, in order to ensure ventilation, install inverters side by side. If it is necessary to install several inverters above each other, you need additional ventilation.
- Never touch the internal elements for 15 minutes after power goes off. Wait until it is completely discharged. Use a meter capable of measuring up to 1500 VDC & 600 VAC RMS to confirm that less than 50V is present on the DC BUS and between all power terminals and earth before working on or near the DC Bus
- Input terminals L1/R, L2/S and L3/T are connected to power supply of 400V/230V (L1, L2 are connected to 230V) while output terminals U, V and W are connected to motor.
- Proper grounding should be ensured. Separate grounding is required for motor and inverter. Grounding with series connection is forbidden.
- There should be separate wiring between control loop and power loop to avoid any possible interference.
- Cable length should be minimized to limit common mode interference.
- If circuit breaker or contactor needs to be connected between the drive and the motor, be sure to operate these circuit breakers or contactor when the drive has no output, to avoid damaging the drive.
- Before using the drive, the insulation of the motors must be checked, especially if it is used for the first time or if it has been stored for a long time. This is to reduce the risk of the drive being damaged by poor insulation of the motor.
- Do not connect any varistor or capacitor to the output terminals of the drive because the drive's output voltage waveform is pulse wave, otherwise tripping or damaging of components may occur.
- Ensure the installation complies with all local and national electrical codes.

3-2 Installation

3.2 Minimum Air Clearance

- See Chapter 7 Installation and Connection for clearance information.

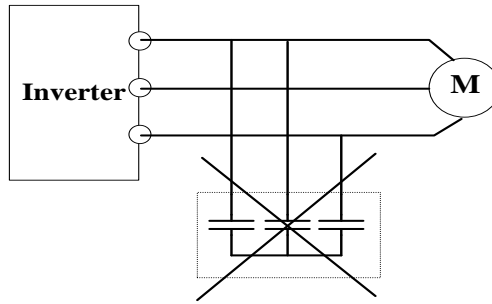

Figure 3-1 Capacitors are prohibited to be used

- Derating must be considered when the drive is installed at high altitude (greater than 1000m). This is because the cooling effect of drive is deteriorated due to the thin air, as shown in Figure 3-2 that indicates the relationship between the elevation and rated current of the drive.

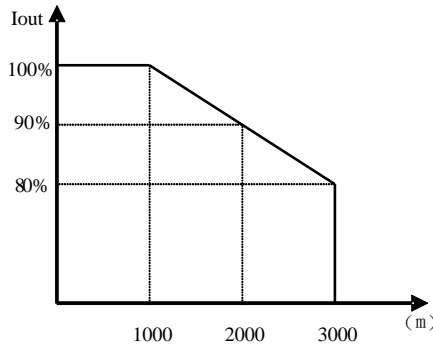
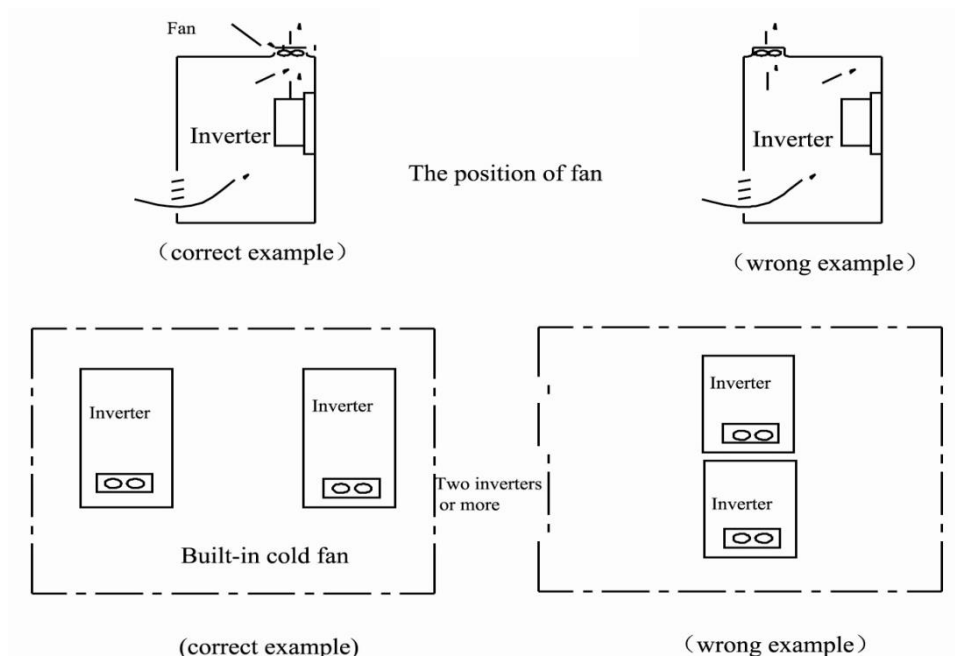

Figure 3-2 Derating drive's output current with altitude

Temperature derating

		Power of drive (kW)																									
		0.2	0.37	0.55	0.75	1.1	1.5	2.2	3.7	4	5.5	7.5	11	15	18.5	22	30	37	45	55	75	90	110	132	160	180	
Power of Motor (kW)	0.2	40C	50C	50C	50C	50C	50C	50C	50C	50C	50C	50C	50C	50C	50C	50C	50C	50C	50C	50C	50C	50C	50C	50C	50C	50C	
	0.37	30C	40C	50C	50C	50C	50C	50C	50C	50C	50C	50C	50C	50C	50C	50C	50C	50C	50C	50C	50C	50C	50C	50C	50C	50C	50C
	0.55	20C	30C	40C	50C	50C	50C	50C	50C	50C	50C	50C	50C	50C	50C	50C	50C	50C	50C	50C	50C	50C	50C	50C	50C	50C	50C
	0.75		20C	30C	40C	45C	50C	50C	50C	50C	50C	50C	50C	50C	50C	50C	50C	50C	50C	50C	50C	50C	50C	50C	50C	50C	50C
	1.1				30C	40C	45C	50C	50C	50C	50C	50C	50C	50C	50C	50C	50C	50C	50C	50C	50C	50C	50C	50C	50C	50C	50C
	1.5					30C	40C	50C	50C	50C	50C	50C	50C	50C	50C	50C	50C	50C	50C	50C	50C	50C	50C	50C	50C	50C	50C
	2.2						35C	40C	50C	50C	50C	50C	50C	50C	50C	50C	50C	50C	50C	50C	50C	50C	50C	50C	50C	50C	50C
	3.7							25C	40C	50C	50C	50C	50C	50C	50C	50C	50C	50C	50C	50C	50C	50C	50C	50C	50C	50C	50C
	4								30C	40C	50C	50C	50C	50C	50C	50C	50C	50C	50C	50C	50C	50C	50C	50C	50C	50C	50C
	5.5									30C	40C	50C	50C	50C	50C	50C	50C	50C	50C	50C	50C	50C	50C	50C	50C	50C	50C
	7.5										25C	40C	50C	50C	50C	50C	50C	50C	50C	50C	50C	50C	50C	50C	50C	50C	50C
	11											20C	40C	50C	50C	50C	50C	50C	50C	50C	50C	50C	50C	50C	50C	50C	50C
	15												20C	40C	50C	50C	50C	50C	50C	50C	50C	50C	50C	50C	50C	50C	50C
	18.5													20C	40C	50C	50C	50C	50C	50C	50C	50C	50C	50C	50C	50C	50C
	22														20C	40C	50C	50C	50C	50C	50C	50C	50C	50C	50C	50C	50C
	30															20C	40C	50C	50C	50C	50C	50C	50C	50C	50C	50C	50C
	37																20C	40C	50C	50C	50C	50C	50C	50C	50C	50C	50C
	45																	20C	40C	50C	50C	50C	50C	50C	50C	50C	50C
	55																		20C	40C	50C	50C	50C	50C	50C	50C	50C
	75																			20C	40C	50C	50C	50C	50C	50C	50C
	90																				20C	40C	50C	50C	50C	50C	50C
	110																					20C	40C	50C	50C	50C	50C
132																						20C	40C	50C	50C	50C	
160																							20C	40C	50C	50C	
180																								20C	40C	50C	

3.3 Inverters Installed in a Control Cabinet



Chapter 4 Maintenance

4.1 Periodic Checking

Cooling fan and ventilation channel should be cleaned regularly to check it is clear; remove any dust accumulated in the inverter on a regular basis.

Check inverter's input and output wiring and wiring terminals regularly and check if wirings are ageing.

Check whether screws on each terminals are fastened.

4.2 Storage

Store the inverter in the original packing case.

If the inverter is stored for long time, power the inverter at minimum intervals of 6 months to prevent the electrolytic capacitors being damaged. The inverter should be powered up for longer than 5 hours. If the inverter is stored for longer than 18 months without powering it up, the capacitors will have to be reformed or damage may occur to the inverter when power is applied.

4.3 Daily Maintenance

Environment temperature, humidity, dust and vibration would decrease the life of inverter. Daily maintenance is necessary to inverters.

Daily inspecting:

Inspect the motor for unusual noise when it is operating.

Inspect for abnormal vibration of the motor when it is operating.

Inspect the environmental operating conditions of the inverter.

Inspect for proper operation of the fan and inverter temperature.

Daily cleaning:

Keep the inverter clean. Clean surface dust of inverter to prevent dust, metal powder, oily dirt and water from dropping into the inverter.

4.4 Returning the Unit to Parker SSD Drives

Please have the following information available:

- The model and serial number - see the unit's rating label
- Details of the fault

Contact your nearest Parker SSD Drives Service Center to arrange return of the item. You will be given a *Returned Material Authorization*. Use this as a reference on all paperwork you return with the faulty item. Pack and return the item in the original packing materials; or at least an anti-static enclosure. Do not allow packaging chips to enter the unit.

Chapter 5 The Keypad

5.1 The Display

The panel covers three sections: **data display section**, **status indicating section** and **keypad operating section**, as shown in Figure 5-1.

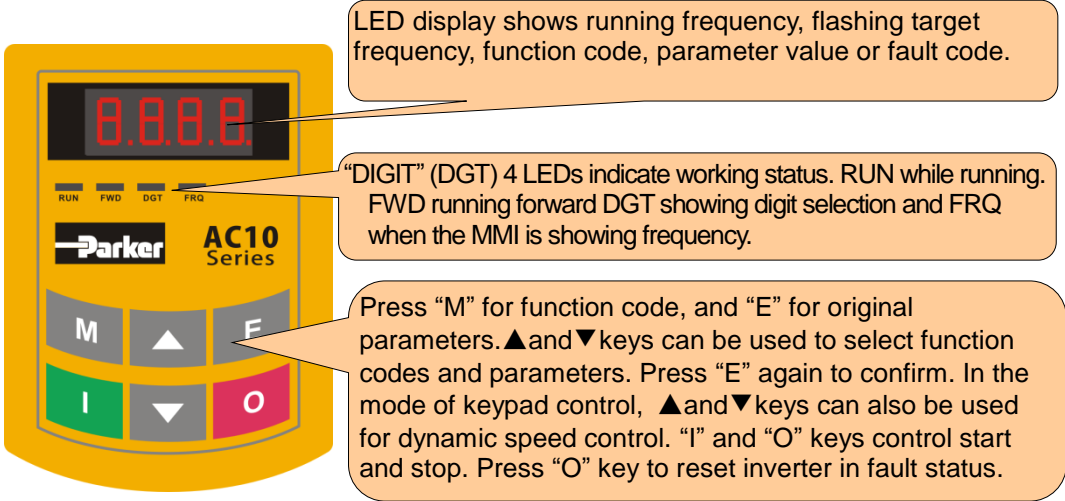

Figure 5-1 Keypad Display

5.2 Remote-control

The remote mounted keypad can be ordered as 1001-00-00.

This includes the keypad, cable and mounting brackets.

Layout diagram

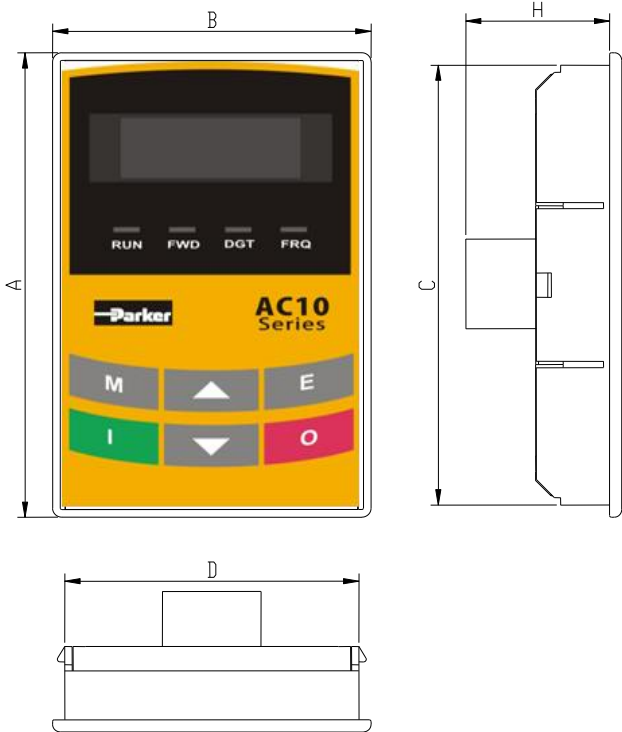

Keypad Measurements (Unit:mm)

Code	A	B	C	D	H	Opening size
1001-00-00	124	74	120	70	26	121*71

5-2 The Keypad

5.2.1 Panel Mounting Dimensions

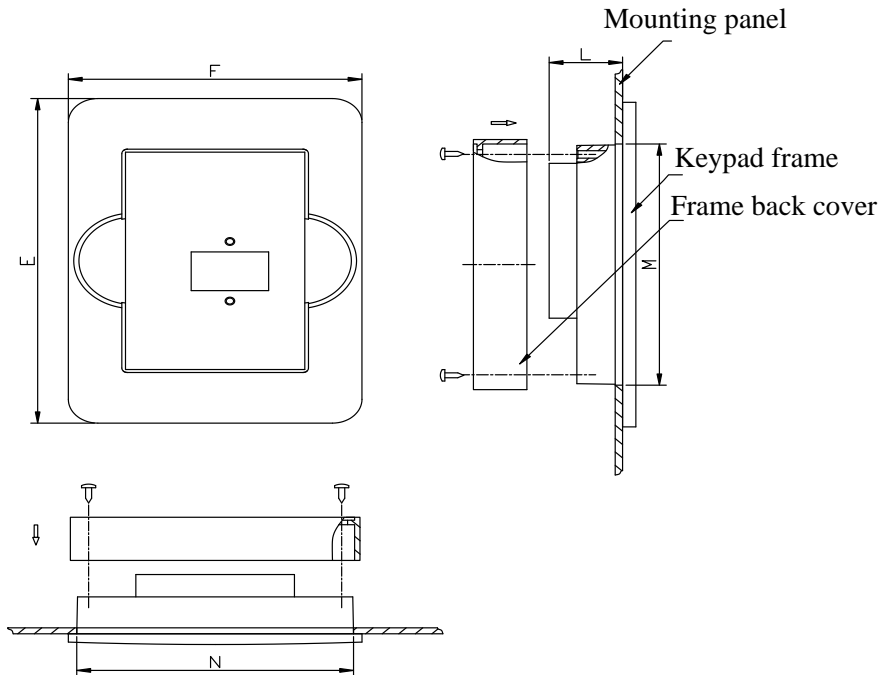

Keypad panel size			Opening size	
E	F	L	N	M
170	110	22	102	142

5.2.1 Port of control panel

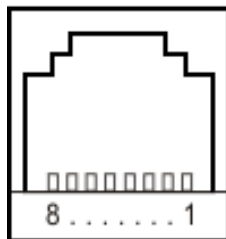







Pins	1	2	3	4	5	6	7	8
8 core	None	5V	Grounding	Grounding	Signal 1	Signal 2	Signal 3	Signal 4

The default length of remote cable is 1m. On the occasion of heavy interference or if remote control cable is longer than 3m, please add Ferrite core on the cable. **This connector is for external keypad use only.**

Chapter 6 The Menu Structure

All keys on the panel are available for user. Refer to Table 6-1 for their functions.















Table 6-1 Uses of Keys

Keys	Names	Remarks
	Menu	To call function code and switch over display mode.
	Enter	To call and save data.
	Up	To increase data (speed control or setting parameters)
	Down	To decrease data (speed control or setting parameters)
	Run	To start inverter
	Stop or Reset	To stop inverter; to reset in fault status. To change function codes in a code group or between two code groups. Toggles between incrementing function code by 1 or by 100 in the interface of function code, keep pressing "O" key for 3s, inverter will be stopped. (if stop command is controlled by keypad).

6.1 Parameters Setting

This inverter has numerous function parameters that the user can modify to effect different modes of operation. The user should be aware that if they set password valid (F107=1), the password must be entered first.

Table 6-2 Steps for Parameters Setting

Steps	Keys	Operation	Display
1		Press "M" key to display function code	
2	 or 	Press "Up" or "Down" to select required function code	
3		Read data set in the function code	
4	 or 	To modify data	
5		Shows corresponding target frequency by flashing after saving the set data	
		Displays the current function code	

The above-mentioned step should be operated when inverter is in stop status.

6-2 The Menu

6.1.1 Function Codes Switchover in/between Code-Groups

It has more than 300 parameters (function codes) available to the user, divided into sections as indicated in Table 6-3.

Table 6-3 Function Code Partition

Group Name	Function Code Range	Group No.	Group Name	Function Code Range	Group No.
Basic Parameters	F100~F160	1	Timing control and protection function	F700~F770	7
Run Control Mode	F200~F280	2	Parameters of the motor	F800~F850	8
Multi-functional input/output terminal	F300~F340	3	Communication function	F900~F930	9
Analog signals and pulse of input/output	F400~F480	4	PID parameter setting	FA00~FA80	10
Multi-stage speed Parameters	F500~F580	5	Torque control	FC00~FC40	11
Subsidiary function	F600~F670	6			

As parameter setting can take time due to numerous function codes, such function is specially designed as “Function Code Switchover in a Code Group or between Two Code-Groups” so that parameters setting becomes convenient and simple.

Press “M” key so that the keypad controller will display function code. If user presses “▲” or “▼” key, the function code will circularly keep increasing or decreasing by degrees within the group; if user presses the “O” key again, the function code will change circularly between two code groups when operating the “▲” or “▼” key, e.g. when function code shows F111 and DGT indicator is on, press “▲”/“▼” key, function code will keep increasing or decreasing by degrees within F100~F160; press “O” key again, DGT indicator will be off. When pressing “▲”/“▼” key, function codes will change circularly among the 10 code-groups, like F211, F311...FA11, F111..., Refer to Figure 6-1 (The flashing “50.00” is indicated the corresponding target frequency values).

(The flashing “50.00” is indicated the corresponding target frequency values).

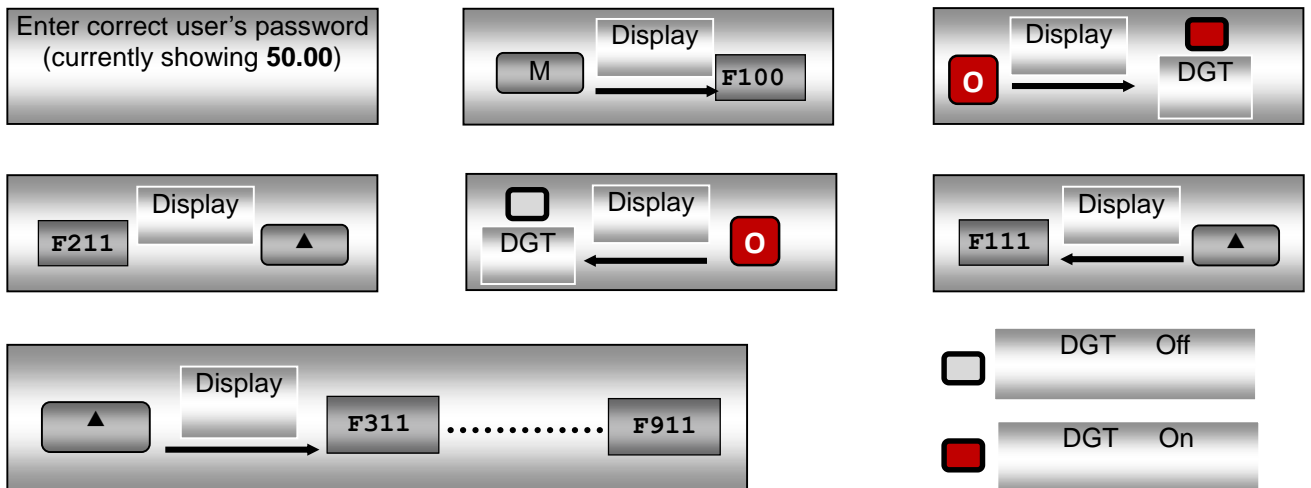

Figure 6-1 Switch over in a Code Group or between Different Code-Groups

6.1.2 Panel Display

Table 6-4 Items and Remarks Displayed on the Panel

Items	Remarks
AErr	Analog Input has open connection
CE	Indicates Communication error
Err2	Tuning parameters are set wrong
Err3	Instantaneous Over Current
Err4	Current Sampling Fault
Err5	PID parameters are set wrong
Err6	Watchdog Fault
ESP	External coast stop terminal is closed, ESP will be displayed.
FL	Indicates Flycatching fault condition
LU	Indicates under-voltage for input condition
HF-0	This Item will be displayed when you press “M” in stopping status, which indicates jogging operation is valid. But HF-0 will be displayed only after you change the value of F132.
-HF-	It stands for resetting process and will display target frequency after reset.
OC	Indicates over-current condition (OC)
OC1	Indicates over-current condition (OC1)
OE	Indicates over-voltage condition
OH	Indicates heatsink over-heat condition
OH1	Indicates external over-heat condition
OL1	Indicates inverter over-load condition
OL2	Indicates motor over-load condition
PF0	Indicates phase loss for output condition
PF1	Indicates phase loss for input condition
10.00	Indicating inverter’s current running frequency (or rotate speed) and parameter setting values, etc.
50.00	Flashing in stopping status to display target frequency.
0.	Holding time when changing the running direction. When “Stop” or “Free Stop (Coast Stop)” command is executed, the holding time can be cancelled.
A100	Output current (100A). Keep one digit to the right of the decimal point when current is below 100A.
b*.*	PID feedback value is displayed.
F152	Function code (parameter code).
H *	Heat Sink temperature is displayed.
L***	Linear speed is displayed.
o*.*	PID given value is displayed.
u100	DC Bus voltage (100V).
U100	Output voltage (100V).

7-1 Installation & Connection

Chapter 7 Installation & Connection

7.1 Installation

Inverter should be installed vertically, as shown in Figure 7-1. Sufficient ventilation space should be ensured in its surrounding.

Clearance dimensions (recommended) are available from Table 7-1 Clearance Dimensions for installing of the inverter. Space between 2 drives 25mm.

Table 7-1 Clearance Dimensions

Model	Clearance Dimensions	
Plastic Housing	A≥150mm	B≥50mm
Metal Housing	A≥200mm	B≥100mm

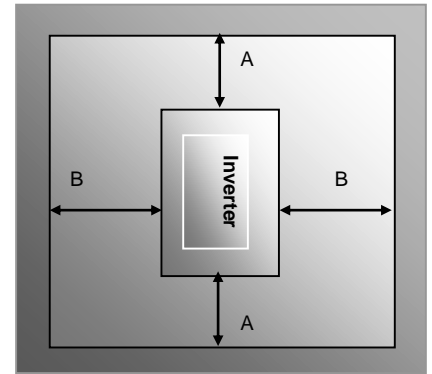
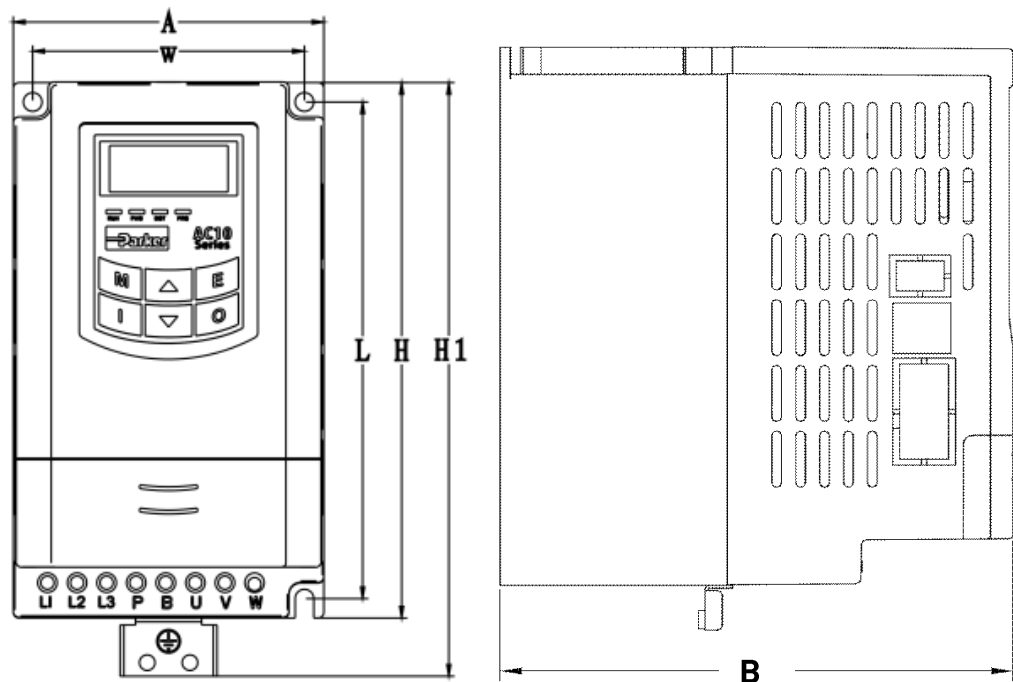

Figure 7-1 Installation Sketch

Frame	Part Number	External Dimension AxBxH (H1) mm	Max Weight kg	Mounting Size(WxL)	Mounting Bolt
1	10G-X1-XXXX-XX	80x135x138 (153)	1.25	70x128	M4
2	10G-X2-XXXX-XX	106x150x180 (195)	1.76	94x170	M4
3	10G-43-XXXX-XX	138x152 x235 (250)	2.96	126x225	M5
4	10G-44-XXXX-XX	156x170x265 (280)	4.9	146x255	M5
5	10G-45-XXXX-XX	205x196 x340 (355)	7.5	194x330	M5
6	10G-46-XXXX-XX	265 x 235 x 435	17	235x412	M6
7	10G-47-XXXX-XX	315 x 234 x 480	25	274x465	M8
8	10G-48-XXXX-XX	360 x 265 x 555	40	320x530	M8
9	10G-49-XXXX-XX	410 x 300 x 630	55	370x600	M10
10	10G-410-XXXX-XX	516 x 326 x 765	94	360x740	M10
11	10G-411-XXXX-XX	560 x 342 x 910	120	390x882	M10



Plastic Cover Layout
Frames 1 – 5

Note: H is the size of inverter without grounding plate.
H1 is the size of inverter with grounding plate.

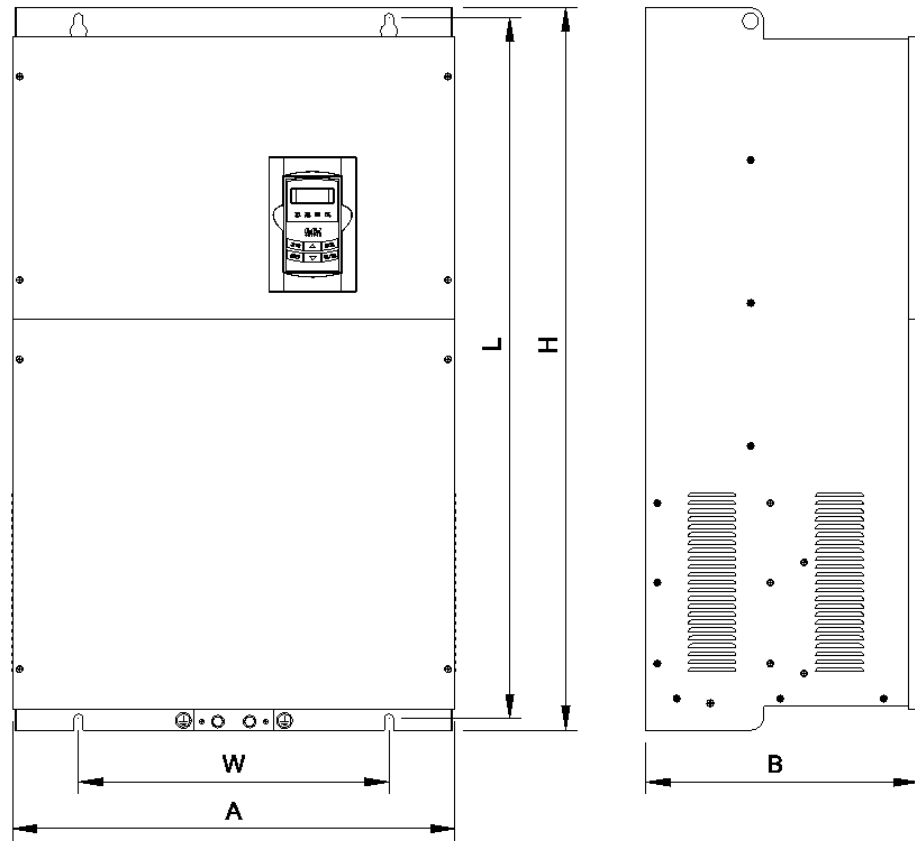

Metal Cover Layout
Frames 6 - 11

7-3 Installation & Connection

7.2 Connection

Connect R/L1, S/L2 and T/L3 terminals (L1/R and L2/S terminals for single-phase) with power supply,  to grounding, and U, V and W terminals to motor.

Motor shall have to be grounded. Otherwise connected motor causes interference.

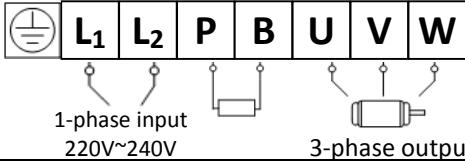
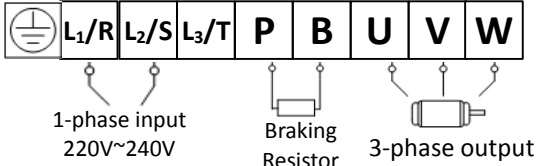
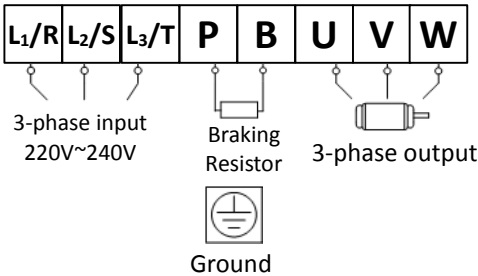
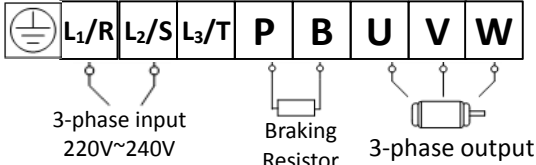
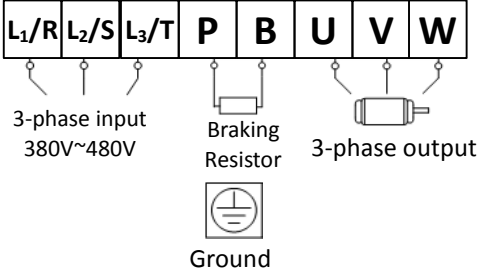
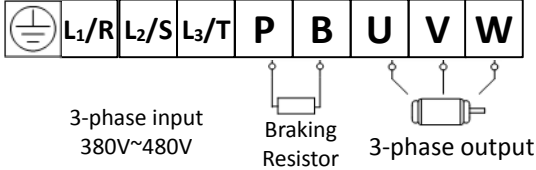
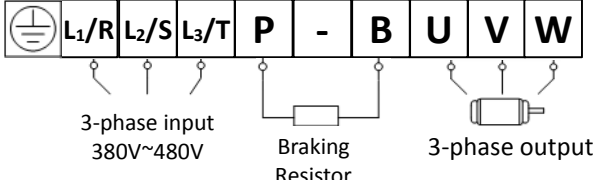
Model	Sketch
Frame 1 1-phase 230V 0.2kW~0.75kW	
Frame 2 1-phase 230V 1.1kW~2.2kW	
Frame 1 3-phase 230V 0.2kW~0.75kW	
Frame 2 3-phase 230V 1.1kW~2.2kW	
Frame 1 3-phase 400V 0.2kW~0.55kW	
Frame 2 – Frame 4 3-phase 400V 0.75kW~11kW 3-phase 230V 4kW~11kW	
Frame 5 3-phase 400V 15kW~22kW 3-phase 230V 7.5kW~11kW	

Model	Sketch
<p>Frame 6 – Frame 11</p> <p>3-phase 400V 30kW and above</p> <p>Frame 6 only: 3-phase 230V 15kW</p>	<p style="text-align: center;">Braking Resistor 3-phase input 380V~480V 3-phase output</p>

7.2.1 Power Terminals

Terminals	Terminal Marking	Terminal Function Description
Power Input Terminal	R/L1, S/L2, T/L3	Input terminals of three-phase 400V AC voltage (R/L1 and S/L2 terminals for single-phase)
Output Terminal	U, V, W	Inverter power output terminal, connected to motor.
Grounding Terminal		Inverter grounding terminal.
Braking Terminal	P, B	External braking resistor (Note: no Terminals P or B for inverter without built-in braking unit).
	P, -	DC bus-line output External connections to optional braking unit P connected to input terminal "P" or "DC+" of braking unit, - connected to input terminal of braking unit "N" or "DC-".

7.2.2 Control Terminals

For 22kW and below:

TA	TB	TC	DO1	24V	CM	DI1	DI2	DI3	DI4	DI5	DI6	10V	AI1	AI2	GND	AO1	AO2
----	----	----	-----	-----	----	-----	-----	-----	-----	-----	-----	-----	-----	-----	-----	-----	-----

For 30~180kW:

TA	TB	TC	DO1	DO2	24V	CM	DI1	DI2	DI3	DI4	DI5	DI6	DI7	DI8	10V	AI1	AI2	GND	AO1	AO2
----	----	----	-----	-----	-----	----	-----	-----	-----	-----	-----	-----	-----	-----	-----	-----	-----	-----	-----	-----

Modbus RTU/RS485

On side of the drive for frames 1 – 5, under front cover for frames 6 - 11

GND	5V	A+	B-
-----	----	----	----

7-5 Installation & Connection

7.3 Measurement of Main Circuit Voltages, Currents and Powers

Since the voltages and currents on the inverter power supply and output sides include harmonics, measurement data depends on the instruments used and circuits measured. When instruments for commercial frequency are used for measurement, measure the following circuits with the recommended instruments.

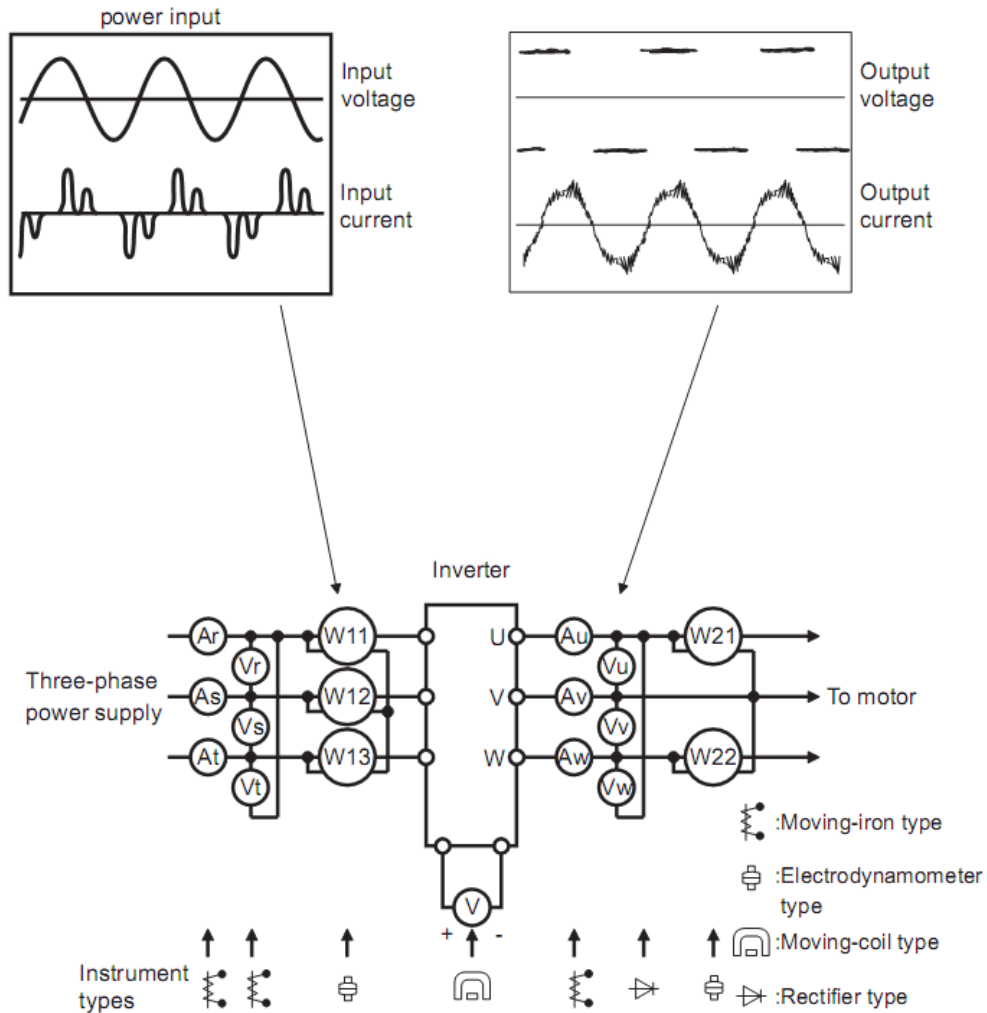

Table 7-2

Item	Measuring Point	Measuring Instrument	Remarks (Reference Measurement Value)
Power supply voltage V1	Across R-S, S-T, T-R	Moving-iron type AC voltmeter	400V±15%, 230V±15%
Power supply side current I1	R, S, and T line currents	Moving-iron type AC voltmeter	
Power supply side power P1	At R, S and T, and across R-S, S-T and T-R	Electrodynamic type single-phase wattmeter	P1=W11+W12+W13 (3-wattmeter method)
Power supply side power factor Pf1	Calculate after measuring power supply voltage, power supply side current and power supply side power. [Three phase power supply] $Pf1 = \frac{P1}{\sqrt{3}V1 \times I1} \times 100\%$		
Output side voltage V2	Across U-V, V-W and W-U	Rectifier type AC voltmeter (Moving-iron type cannot measure)	Difference between the phases is within ±1% of the maximum output voltage.
Output side current I2	U, V and W line currents	Moving-iron type AC Ammeter	Current should be equal to or less than rated inverter current. Difference between the phases is 10% or lower of the rated inverter current.
Output side power P2	U, V, W and U-V, V-W, W-U	Electro dynamic type single-phase wattmeter	P2 = W21 + W22 2-wattmeter method
Output side power factor Pf2	Calculate in similar manner to power supply side power factor: $Pf2 = \frac{P2}{\sqrt{3}V2 \times I2} \times 100\%$		
Converter output	Across P+ (positive) and - (negative)	Moving-coil type (such as multi-meter)	DC voltage, the value is $\sqrt{2} \times V1$
Power supply of control PCB	Across 10V-GND	Moving-coil type (such as multi-meter)	DC10V±0.2V
	Across 24V-CM	Moving-coil type (such as multi-meter)	DC24V±1.5V
Analog output AO1	Across AO1-GND	Moving-coil type (such as multi-meter)	Approx. DC10V at max frequency.
Alarm signal	Across TA/TC Across TB/TC	Moving-coil type (such as multi-meter)	<Normal> <Abnormal> Across TA/TC: Discontinuity Continuity Across TB/TC: Continuity Discontinuity

7-7 Installation & Connection

7.4 Functions of Control Terminals

To operate the inverter the user must operate the control terminals correctly and flexibly. The following is a description of the user terminals and any relevant parameters.

Table 7-3 Functions of Control Terminals

Terminal	Type	Description	Function
DO1	Output Signal	Multifunctional output terminal 1	When the function is true, the value between this terminal and CM is 0V; when the function is false, the value is 24V. Output current 2mA. TC is a common point, TB-TC are normally closed contacts, TA-TC are normally open contacts. The contact capacity is 10A/125VAC, 5A/250VAC, 5A/30VDC. (See note 3)
DO2 <i>Note 1</i>		Multifunctional output terminal 2	
TA			
TB			
TC		Relay contact	
AO1	Analog output	Running frequency	It is connected with frequency meter, speedometer or ammeter externally, and its minus pole is connected with GND. See F423~F426 for details.
AO2		Current display	
10V	Analog power supply	Self contained power supply	Internal 10V self-contained power supply of the inverter provides power to the inverter. When used externally, it can only be used as the power supply for voltage control signal, with current restricted below 20mA.
AI1	Input Signal	Voltage / Current analog input	When analog speed control is selected, the voltage or current signal is input through this terminal. The range of voltage input is 0~10V and the current input is 0~20mA, the input resistor is 500Ohm, and grounding: GND. If the input is 4~20mA, it can be realised by setting F406 to 2. The voltage or current signal can be chosen by coding switch. See Table 8-2 and Table 8-3 for details, the default setting of AI1 is 0~10V, and the default setting of AI2 is 0-20mA.
AI2			
GND		Self-contained Power supply Ground	Ground terminal of external control signal (voltage control signal or current source control signal) is also the ground of 10V power supply of this inverter.
24V	Power supply	Control power supply	Power: 24±1.5V, grounding is CM; current is restricted below 50mA for external use.
D11	Digital input control terminal	Jogging terminal	When this terminal is valid, the inverter will have jogging running. The jogging function of this terminal is valid under both at stopped and running status.
D12		External Coast Stop	When this terminal is valid, "ESP" malfunction signal will be displayed.
D13		"FWD" Terminal	When this terminal is valid, inverter will run forward.
D14		"REV" Terminal	When this terminal is valid, inverter will run reverse.
D15		Reset terminal	Make this terminal valid under fault status to reset the inverter.
D16 <i>Note 1</i>		Free stop	Make this terminal valid during running can realize free stop.
D17 <i>Note 1</i>		Run Terminal	When this terminal is in the valid state, inverter will run by the acceleration time.
D18 <i>Note 1</i>		Stop terminal	Make this terminal valid during running can realize stop by the deceleration time.
GND <i>Note 2</i>	RS485 communication terminals	Grounding of differential signal	Ground of differential signal
5V <i>Note 2</i>		Power of differential signal	Power of differential signal
A+ <i>Note 2</i>		Positive polarity of differential signal	Standard: TIA/EIA-485(RS-485) Communication protocol: Modbus Communication rate: 1200/2400/4800/9600/19200/38400/57600bps
B- <i>Note 2</i>		Negative polarity of Differential signal	

Note 1: This terminal is not included in 22kW and below 22Kw inverters.

Note 2: GND, 5V, A+, and B- are on separate 4-pole terminal block.

Note 3: The contact capacity for 30kW and above 30kW inverters is 10A/125VAC, NO/NC 3A, 250VAC/30VDC.

Note 4: The "true" state for these terminals is either 24V when configured for PNP operation or 0V when configured for NPN Operation.

7.5 Wiring for Digital Input Terminals:

Generally, shielded cable is recommended and wiring distance should be as short as possible. When the analogue reference signal is used, it is necessary to take measures to prevent power supply interference (noise).

Digital input terminals are only connected for NPN mode (source) or for PNP mode (sink). Select NPN or PNP mode by sliding the switch J7 to "NPN" or "PNP".

Wiring for control terminals as follows:

7.5.1 Wiring for positive source electrode (NPN mode).

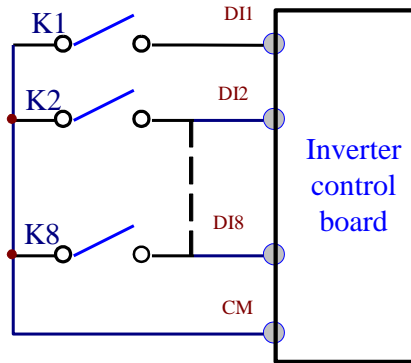

7.5.2 Wiring for active source electrode

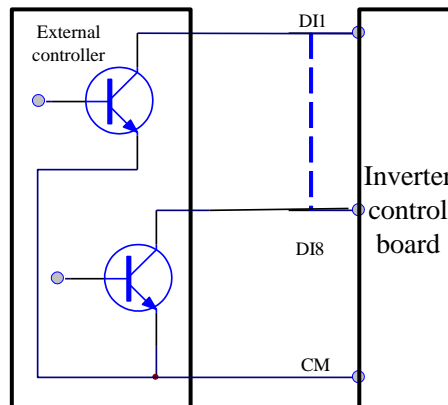

If digital input control terminals are connected by sink electrode, slide the toggle switch to the end of "PNP". Wiring for control terminals as follows:

7-9 Installation & Connection

7.5.3 Wiring for positive Sink electrode (PNP mode) – Switch J7 set for PNP.

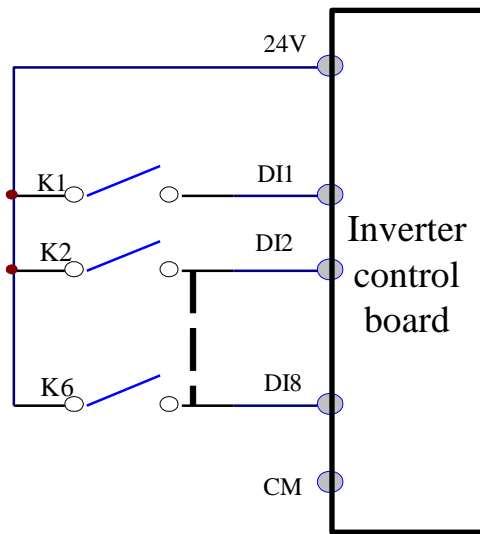

7.5.4 Wiring for active drain electrode (PNP mode) (Common Collector Mode)

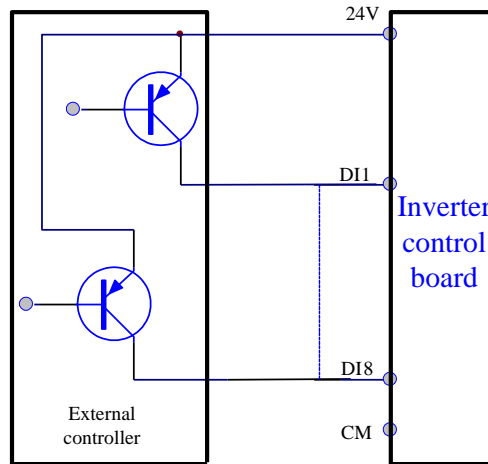

The most prevalent wiring mode for I/O depends on where the system is located. In many parts of the world “sink or pull-down” configurations are used, and PNP mode is generally used. In many other parts of the world “source or pull-up” configurations are used, and NPN mode is typically used. The user should choose wiring mode according to the application requirement.

Instructions of choosing NPN mode or PNP mode:

1. There is a toggle switch J7 near to control terminals. See Figure 7-2.
2. When turning J7 to “NPN”, DI terminal is connected to CM for TRUE.
3. When turning J7 to “PNP”, DI terminal is connected to 24V for TRUE.

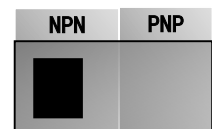

Figure 7-2 Toggle Switch J7

NOTE: J7 is on the back of control board for single-phase inverter 0.2-0.75KW.

7.6 Connection Overview

Refer to following figure for the overall connection for AC10 series inverters. Various wiring modes are available for the terminals whereas not every terminal needs to be connected in each mode when applied.

Note:

1. Only connect power terminals L1/R and L2/S to supply voltage for single-phase inverters.
2. The contact capacity for 22kW and below 22kW is 10A/125VAC、5A/250VAC、5A/30VDC.
The contact capacity for above 22kW is 10A/125VAC、NO/NC: 3A 250VAC/30VDC.

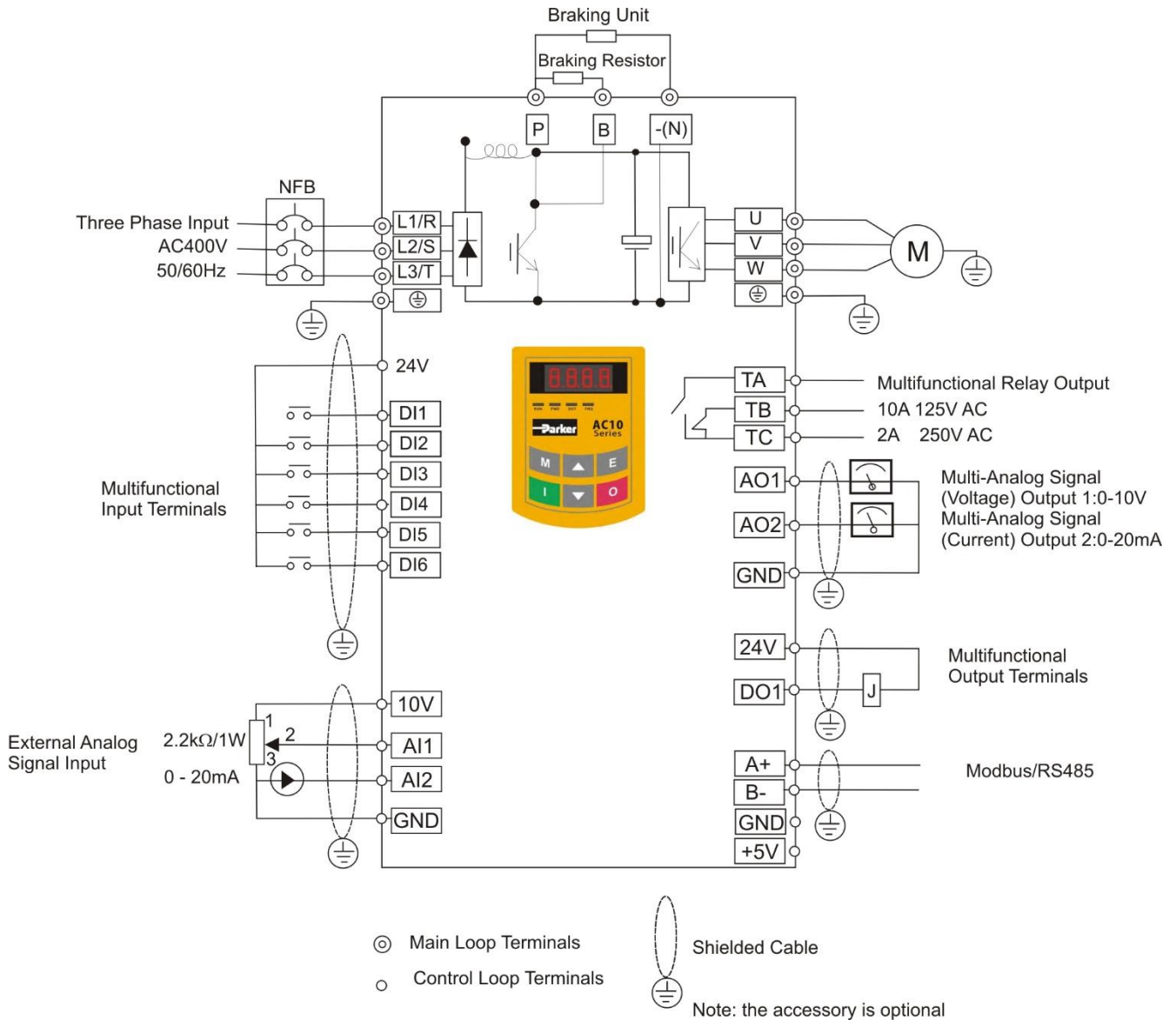

0.2kW – 22kW Basic Wiring Diagram for Multi-stage speed control macro (PNP type)

7-11 Installation & Connection

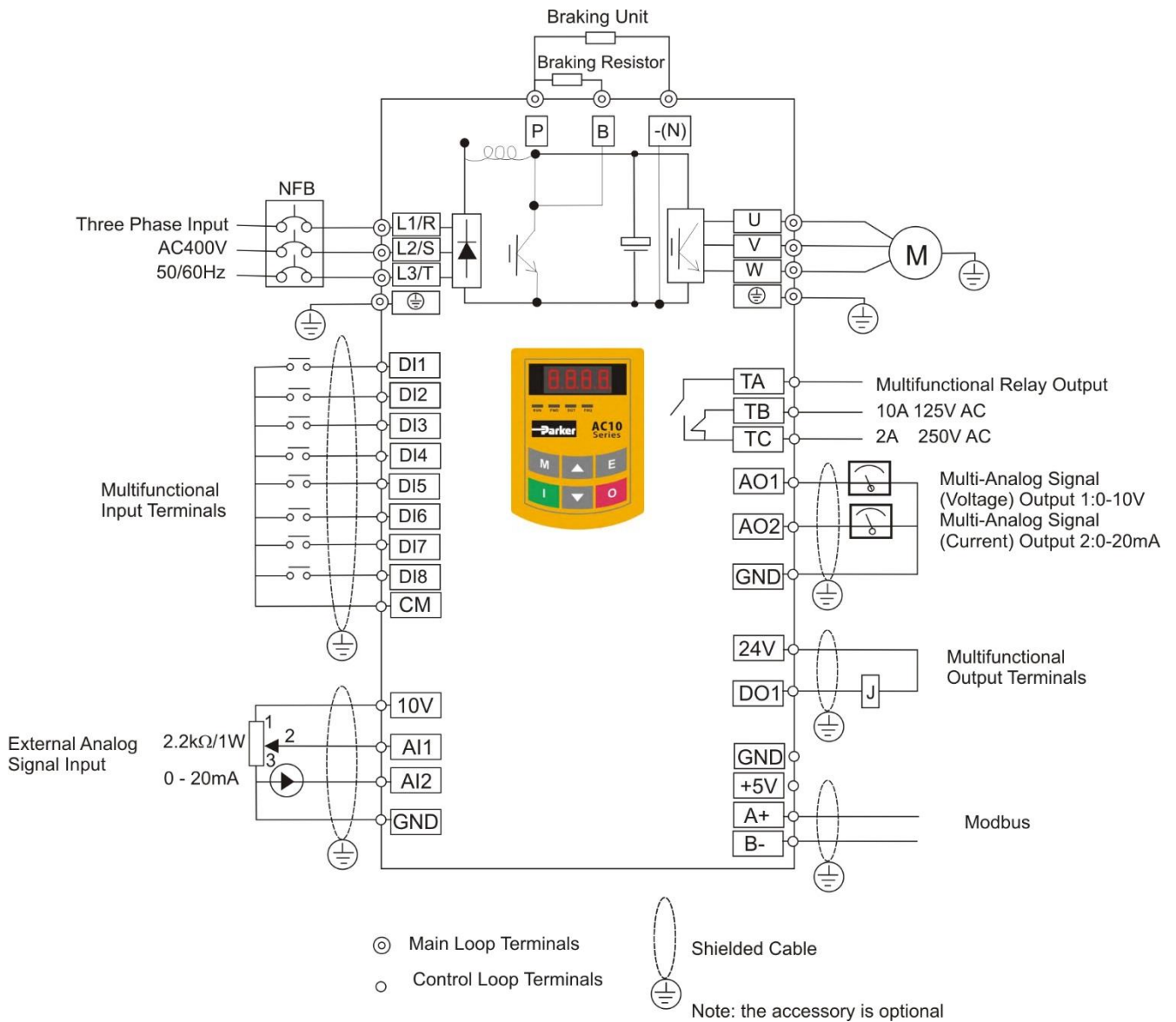

30kW – 180kW Basic Wiring Diagram for Three-phase AC drives (NPN type)

7.6.1 Terminal Tightening Torques

Frame Size	Power PCB Terminal	Control PCB Terminal	Cover	Power Supply, Motor Terminal	Fan	Fan Cover
Frame 1	1.13Nm	0.6Nm	0.6Nm	1.13Nm	1.3Nm	1.3Nm
Frame 2	1.13Nm	0.6Nm	0.6Nm	1.13Nm	1.3Nm	1.3Nm
Frame 3	1.8Nm	0.6Nm	0.6Nm	1.8Nm	1.3Nm	1.3Nm
Frame 4	2.1Nm	0.6Nm	0.6Nm	2.1Nm	1.3Nm	1.3Nm
Frame 5	3.4Nm	0.6Nm	0.6Nm	3.4Nm	1.3Nm	1.3Nm
Frame 6	4.5Nm	0.6Nm	1.3Nm	4.5Nm	0.9Nm	0.9Nm
Frame 7	10 Nm	0.6Nm	1.3Nm	10 Nm	0.9Nm	0.9Nm
Frame 8	10 Nm	0.6Nm	2.4Nm	10 Nm	0.9Nm	0.9Nm
Frame 9	18 Nm	0.6Nm	2.4Nm	18 Nm	0.9Nm	0.9Nm
Frame 10	18 Nm	0.6Nm	2.4Nm	18 Nm	Big fan 1.5Nm Small fan 2.4Nm	
Frame 11	18 Nm	0.6Nm	2.4Nm	18 Nm		

7.7 Basic Methods of Suppressing the Noise

The noise generated by the drive may disturb the equipment nearby. The degree of disturbance is dependent on the drive system, immunity of the equipment, wiring, installation clearance and earthing methods.

7.7.1 Noise propagation paths and suppressing methods

- ① Noise categories

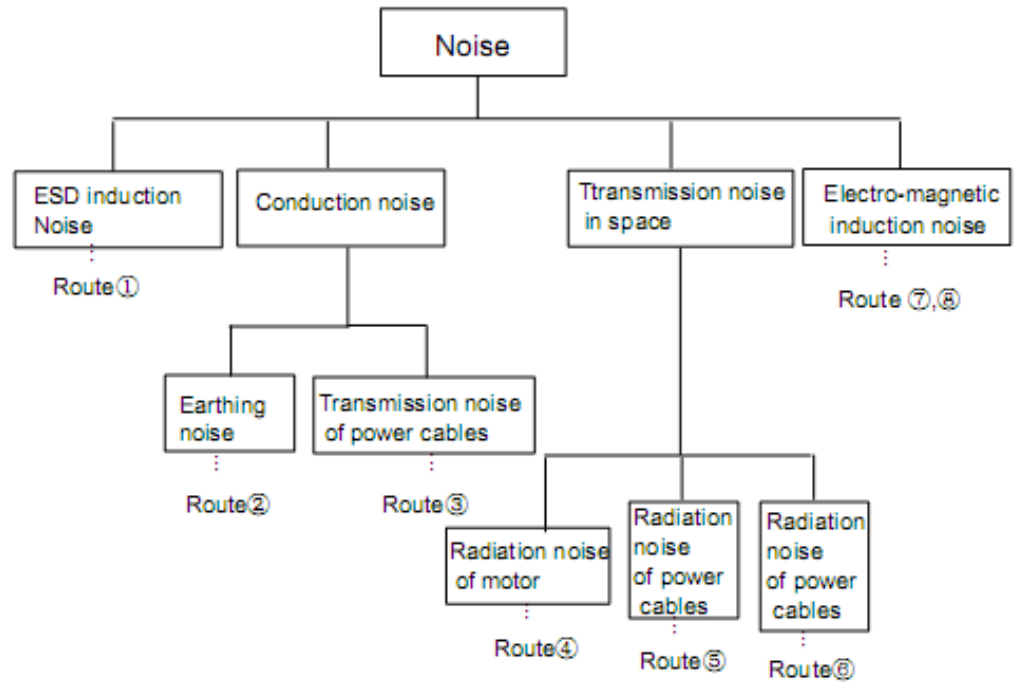

- ③ Noise propagation paths

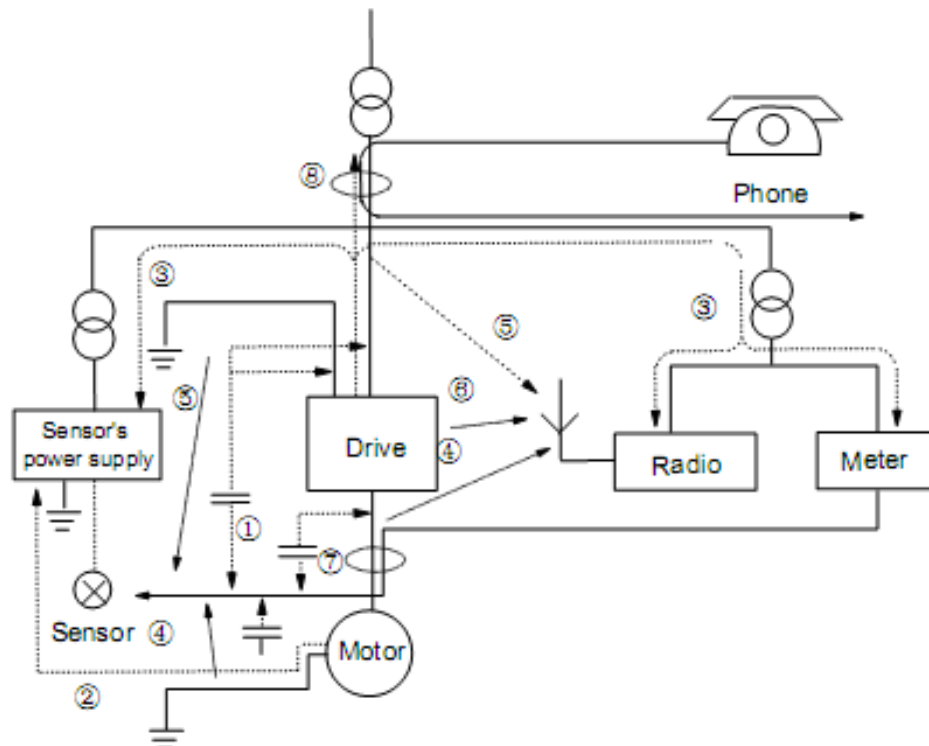

7-13 Installation & Connection

7.7.2 Basic methods of suppressing the noise

Noise Emission Paths	Actions to Reduce the Noise
2	When the external equipment forms a loop with the drive, the equipment may suffer nuisance tripping due to the drive's ground leakage current. The problem can be solved if the equipment is not grounded.
3	If the external equipment shares the same AC supply with the drive, the drive's noise may be transmitted along its input power supply cables, which may cause nuisance tripping to other external equipment. Take the following actions to solve this problem: Install noise filter at the input side of the drive, and use an isolation transformer or line filter to prevent the noise from disturbing the external equipment.
4,5,6	<p>If the signal cables of measuring meters, radio equipment and sensors are installed in a cabinet together with the drive, these equipment cables will be easily disturbed. Take the actions below to solve the problem:</p> <ol style="list-style-type: none"> (1) The equipment and the signal cables should be as far away as possible from the drive. The signal cables should be shielded and the shielding layer should be grounded. The signal cables should be placed inside a metal tube and should be located as far away as possible from the input/output cables of the drive. If the signal cables must cross over the power cables, they should be placed at right angle to one another. (2) Install radio noise filter and linear noise filter (ferrite common-mode choke) at the input and output of the drive to suppress the emission noise of power lines. (3) Motor cables should be placed in a tube thicker than 2mm or buried in a cement conduit. Power cables should be placed inside a metal tube and be grounded by shielding layer
1,7,8	Don't route the signal cables in parallel with the power cables or bundle these cables together because the induced electro-magnetic noise and induced ESD noise may disturb the signal cables. Other equipment should also be located as far away as possible from the drive. The signal cables should be placed inside a metal tube and should be placed as far away as possible from the input/output cables of the drive. The signal cables and power cables should be shielded cables. EMC interference will be further reduced if they could be placed inside metal tubes. The clearance between the metal tubes should be at least 20cm.

7.7.3 Field Wire Connections

Control cables, input power cables and motor cables should be installed separately and enough clearance should be left among the cables, especially when the cables are laid in parallel and the cable length is over 50 metres. If the signal cables must be laid with the power cables, they should be installed parallel to each other.

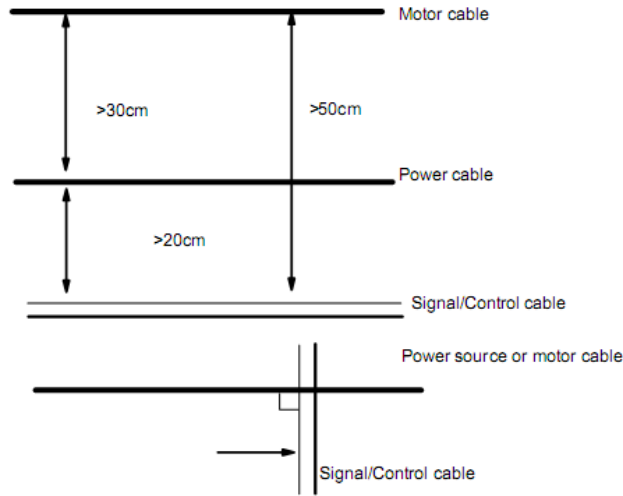

Generally, the control cables should be shielded cables and the shielding metal net must be connected to the metal enclosure of the drive by cable clamps.

7.7.4 Grounding

Independent grounding poles (best)

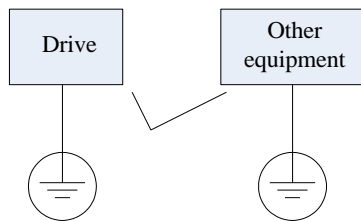

Shared grounding pole (good)

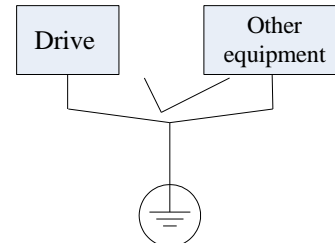

Shared earthing cable (not good)

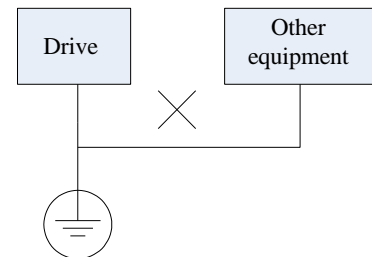
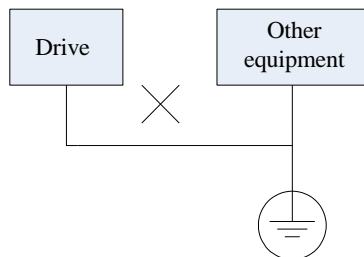

Note:

1. In order to reduce the grounding resistance, flat cable should be used because the high frequency impedance of flat cable is smaller than that of round cable with the same CSA.
2. If the grounding poles of different equipment in one system are connected together, then the leakage current will be a noise source that may disturb the whole system. Therefore, the drive's grounding pole should be separated with the grounding pole of other equipment such as audio equipment, sensors and PC, etc.
3. Grounding cables should be as far away from the I/O cables of the equipment that is sensitive to noise, and also should be as short as possible.

7-15 Installation & Connection

7.7.5 Leakage Current

Leakage current may flow through the drive's input and output capacitors and the motor. The leakage current value is dependent on the distributed capacitance and carrier wave frequency. The leakage current includes ground leakage current and the leakage current between lines.

Ground Leakage Current

The ground leakage current can not only flow into the drive system, but also other equipment via grounding cables. It may cause the leakage current circuit breaker and relays to falsely trip. The higher the drive's carrier wave frequency, the bigger the leakage current, also, the longer the motor cable, the greater the leakage current.

Suppressing Methods

- Reduce the carrier wave frequency, but the motor noise may be louder;
- Motor cables should be as short as possible;
- The drive and other equipment should use leakage current circuit breaker designed for protecting the product against high-order harmonics/surge leakage current.

Leakage Current Between Lines

The line leakage current flowing through the distribution capacitors of the drive outside may cause the thermal relay to be falsely activated, especially for the drive whose power is lower than 7.5kW. When the cable is longer than 50m, the ratio of leakage current to motor rated current may be increased and can cause the wrong action of external thermal relay very easily.

Suppressing Methods

- Reduce the carrier wave frequency, but the motor noise may become louder;
- Install reactor at the output side of the drive.

In order to protect the motor reliably, it is recommended to use a temperature sensor to detect the motor's temperature, and use the drive's over-load protection device (electronic thermal relay) instead of an external thermal relay.

7.7.6 Electrical Installation of the Drive

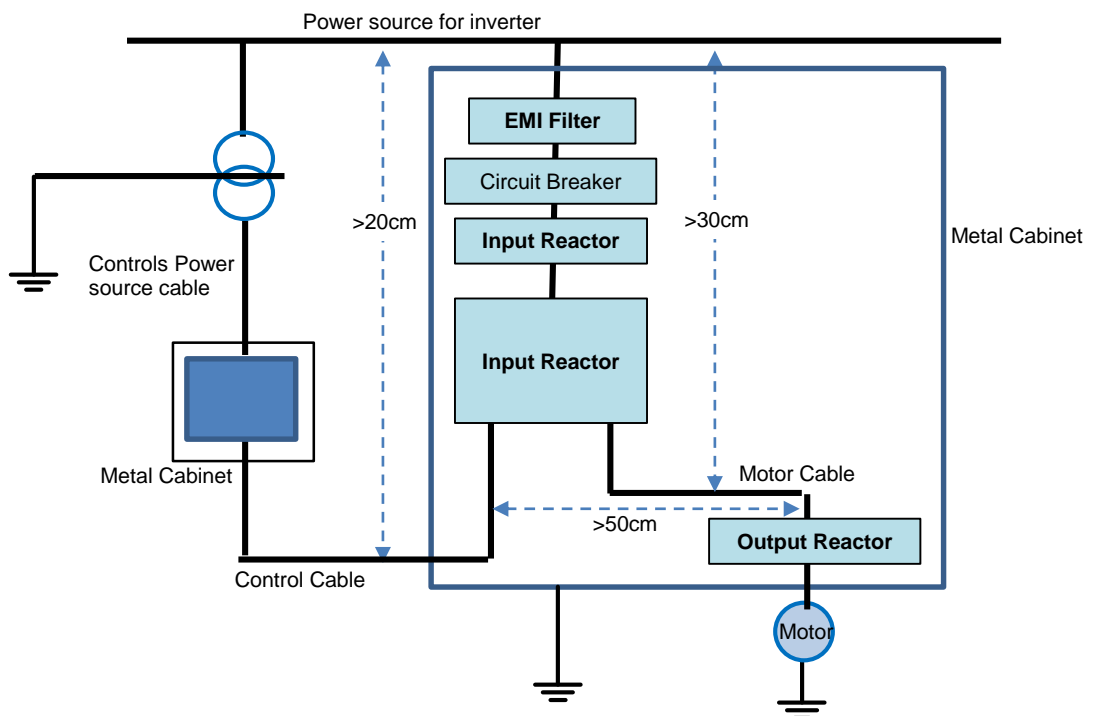

Note:

- The motor cable should be screened and earthed at the drive side, if possible, the motor and drive should be grounded separately;
- Motor cable and control cable should be shielded. The shield must be earthed and avoid entangling at cable end to improve high frequency noise immunity.
- Assure good conductivity among plates, screw and metal case of the drive; use tooth-shape/spring washer and conductive installation plate.

7.7.7 Application of Power Line Filter

Power source filter should be used in the equipment that may generate strong EMI or the equipment that is sensitive to the external EMI. The power source filter should be a two-way low pass filter through which only 50Hz current can flow and high frequency current should be rejected.

Function of Power Line Filter

The power line filter ensures the equipment can satisfy the conducting emission and conducting sensitivity in EMC standard. It can also suppress the radiation of the equipment.

Common mistakes in using power cable filter:

1. Power cable too long

The filter inside the cabinet should be located near to the input power source. The length of the power cables should be as short as possible.

2. The input and output cables of the AC supply filter are too close

The distance between input and output cables of the filter should be as far apart as possible, otherwise the high frequency noise may be coupled between the cables and bypass the filter. This will make the filter ineffective.

3. Bad Grounding of filter

The filter's enclosure must be earthed properly to the metal case of the drive. In order to be earthed well, make use of a special grounding terminal on the filter's enclosure. If you use one cable to connect the filter to the case, the grounding is useless for high frequency interference. When the frequency is high, so is the impedance of cable, hence there is little bypass effect. The filter should be mounted on the enclosure of equipment. Ensure to clear away the insulation paint between the filter case and the enclosure for good grounding contact.

8-1 Operation and Simple Running

Chapter 8 Operation and Simple Running

This chapter defines and explains the terms and names describing the control, running and status of the inverter. Please read it carefully as it will ensure correct operation.

8.1 Basic Conception

Control Mode

AC10 inverter has the following control modes: sensorless vector control (F106=0), V/HZ control (F106=2) and vector control 1 (F106=3).

Mode of Torque Compensation

Under V/HZ control mode, AC10 inverter has four kinds of torque compensation modes:

Linear compensation (F137=0);

Square compensation (F137=1);

User-defined multipoint compensation (F137=2);

Auto torque compensation (F137=3)

Mode of frequency setting

Please refer to F203~F207 for the method for setting the running frequency of the AC10 inverter.

Mode of controlling for running command

The channel for inverter to receive control commands (including start, stop and jogging, etc) contains 5 modes:

0. Keypad control;
1. Terminal control;
2. Keypad + Terminal control
3. Modbus control;
4. Keypad + Terminal +Modbus

The modes of control command can be selected through the function codes F200 and F201.

Operating status of inverter

When the inverter is powered on, it will have one of four types of operating status:

- Stopped status
- Programming status
- Running status
- Fault alarm status

They are described in the following:

Stopped status

If the inverter is re-energised (if “auto-startup after being powered on” is not set) or decelerate the inverter to stop, the inverter is at the stopped status until receiving control command. At this point, the running status indicator on the keypad goes off and the display shows the display status before power down.

Programming status

Through keypad panel, the inverter can be switched to the status that can read or change the function code parameters. Such a status is the programming status.

There are numbers of function parameters in the inverter. By changing these parameters, the user can realize different control modes.

Running status

The inverter at the stopped status or fault-free status will enter running status after having received a start command.

The running indicator on keypad panel lights up under normal running status.

Fault alarm status

The status under which the inverter has a fault and the fault code is displayed.

Fault codes mainly include: OC, OE, OL1, OL2, OH, LU, PF1 and PF0 representing “over current”, “over voltage”, “inverter overload”, “motor overload”, “overheat”, “input under-voltage”, “input phase loss”, and “output phase loss” respectively.

For troubleshooting, please refer to Chapter 10 “Troubleshooting”.

8.2 Keypad Panel and Operation Method

Keypad panel (keypad) is fitted as a standard part for configuration of the AC10 inverter. Using the keypad panel, the user may carry out parameter setting, status monitoring and operation control over the inverter. Both keypad panel and display screen are arranged on the keypad controller, which mainly consists of three sections:

- data display section,
- status indicating section
- and keypad operating section

It is necessary to know the functions and how to use the keypad panel. Please read this manual carefully before operation.

8.2.1 Method of operating the keypad panel

8.2.2 Operation Process of Setting the Parameters using the Keypad Panel

A three-level menu structure is adopted for setting the parameters using the keypad panel, which enables convenient and quick searching and changing of function code parameters.

Three-level menu:

- Function code group (first-level menu)
- Function code (second-level menu)
- Set value of each function code (third-level menu)

8.2.3 Setting the Parameters

Setting the parameters correctly is a precondition to give full inverter performance. The following is the introduction on how to set the parameters using the keypad panel.

Operating procedures:

- Press the “M” key, to enter programming menu.
- Press the key “O”, the DGT lamp goes out. Press ▲ and ▼. This will scroll the first digit after the F, changing the selected function code group. The first number behind F displayed on the panel shows the current function group, in other words, if it displays F1xxat this moment then basic parameters F100 – F160 is selected.
- Press the key “O” again, the DGT lamp lights up. Press ▲ and ▼ to scroll up and down the function code within the selected function group; press the “E” key to display 50.00; while press ▲ and ▼ to change to the need frequency.
- Press the “E” key to complete the change.

8.2.4 Switching and displaying of status parameters

Under stopped status or running status, the LED indicators of inverter can display status parameters of the inverter. Actual parameters displayed can be selected and set through function codes F131 and F132. Through the “M” key, it can switch over repeatedly and display the parameters of stopped status or running status. The followings are the description of operation method of displaying the parameters under stopped status and running status.

8.2.5 Switching of the parameters displayed under stopped status

Under stopped status, by default the inverter has three parameters of stopped status, which can be switched over repeatedly and displayed with the keys “M” and “O”. These parameters are displaying: frequency/function-code, target RPM, DC BUS voltage. Please refer to the

8-3 Operation and Simple Running

description of function code F132 for changing the displayed parameters.

8.2.6 Switching of the parameters displayed under running status

Under running status, by default five parameters of running status can be switched over repeatedly and displayed with the keys "M". These parameters are displayed: output RPM, output current, output voltage, DC BUS voltage. Please refer to the description of function code F131 for changing the displayed parameters.

8.2.7 Operation process of measuring motor parameters

The user shall input the parameters accurately as indicated on the nameplate of the motor prior to selecting operation mode of vector control and auto torque compensation (F137=3) of V/Hz control mode. Inverter will match standard motor stator resistance parameters according to the parameters indicated on the nameplate. To achieve better control performance, the user may start the inverter to measure the motor stator resistance parameters, so as to obtain accurate parameters of the motor controlled.

The motor parameters can be tuned through function code F800.

For example: If the parameters indicated on the nameplate of the motor controlled are as follows: numbers of motor poles are 4; rated power is 7.5kW; rated voltage is 400V; rated current is 15.4A; rated frequency is 50.00HZ; and rated rotary speed is 1440rpm, operation process of measuring the parameters shall be done as described in the following:

In accordance with the above motor parameters, set the values of F801 to F805 correctly: set the value of F801 = 7.5, F802 = 400, F803 = 15.4, F804 = 4 and F805 = 1440 respectively.

Note: The motor nameplate may not indicate the number of poles. The motor RPM listed on the nameplate will be (Synchronous RPM – Slip). The number of motor poles can be interpolated based on the synchronous motor RPM: 3600 = 60Hz, 2 poles; 3000 = 50Hz, 2 poles; 1800 = 60Hz, 4 poles; 1500 = 50Hz, 4 poles; 1200 = 60Hz, 6 poles; 1000 = 50Hz, 6 poles; etc.

Motor nameplate base speed (F805) = [(Base frequency x 120) / poles] – slip

1. ROTATING AUTOTUNE: In order to ensure dynamic control performance of the inverter, set F800=1, i.e. select rotating tuning. Make sure that the motor is disconnected from the load. Press the "I" key on the keypad, and the inverter will display "TEST", and it will tune the motor's parameters of two stages. After that, the motor will accelerate according to the acceleration time set at F114 and maintain for a certain period. The speed of motor will then decelerate to 0 according to the time set at F115. After auto-checking is completed, relevant parameters of the motor will be stored in function codes F806~F809, and F800 will turn to 0 automatically.

2. STATIONARY AUTOTUNE: If it is impossible to disconnect the motor from the load, select F800=2, i.e. stationary tuning. Press the "I" key, the inverter will display "TEST", and it will tune the motor's parameters of two stages. The motor's stator resistance, rotor resistance and leakage inductance will be stored in F806-F808 automatically, and F800 will turn to 0 automatically. The user may also calculate and input the motor's mutual inductance value manually according to actual conditions of the motor.

Note: The preferred method of autotuning is by performing a rotating autotune.

Operation process of simple running

Table 8-1 Brief Introduction to Inverter Operation Process

Process	Operation	Reference
Installation and operation environment	Install the inverter in a location meeting the technical specifications and requirements of the product. Ensure the inverter can operate in the anticipated environmental conditions, and the installation allows adequate heat dissipation.	See Chapters 1, 2, 3.
Wiring of the inverter	Input terminals (LINE), output (motor) terminals; Grounding; Digital I/O terminals, analog I/O terminals, and communication interface, etc.	See Chapters 7 & 8.
Checking before getting energised	Make sure that the voltage of input power supply is correct; the input power supply loop is connected with a breaker; the inverter has been grounded correctly and reliably; the power cable is connected to the power supply input terminals of inverter correctly (R/L1, S/L2 terminals for single-phase power grid, and R/L1, S/L2, and T/L3 for three-phase power grid); the output terminals U, V, and W of the inverter are connected to the motor correctly; the wiring of control terminals is correct; all the external switches are preset correctly; and the motor is under no load (the mechanical load is disconnected from the motor).	See Chapter 7
Checking immediately after energised	Check if there is any abnormal sound, smell with the inverter. Make sure that the display of keypad panel is normal, without any fault alarm message. In case of any abnormality, switch off the power supply immediately.	See Chapter 8
Inputting the parameters indicated on the motor's nameplate correctly, and measuring the motor's parameters.	Make sure to input the parameters indicated on the motor nameplate correctly, and study the parameters of the motor. The users shall check carefully, otherwise, serious problems may arise during running. Before initial running with vector control mode, carry out tuning of motor parameters, to obtain accurate electric parameters of the motor controlled. Before carrying out tuning of the parameters, make sure to disconnect the motor from mechanical load, to make the motor under entirely no load status. It is prohibited to measure the parameters when the motor is at a running status.	See description of parameter group F800~F830
Setting running control parameters	Set the parameters of the inverter and the motor correctly, which mainly include target frequency, upper and lower frequency limits, acceleration/deceleration time, and direction control command, etc. The user can select corresponding running control mode according to actual applications.	See description of parameter group.
Checking under no load	With the motor under no load, start the inverter with the keypad or control terminal. Check and confirm running status of the drive system. Motor's status: stable running, normal running, correct rotary direction, normal acceleration/deceleration process, free from abnormal vibration and abnormal noise. Inverter' status: normal display of the data on keypad panel, normal running of the fan, normal acting sequence of the relay, free from the abnormalities like vibration or noise. In case of any abnormality, stop and check the inverter and motor immediately.	See Chapter 8.
Checking under with Load	After successful test run under no load, connect the load of drive system properly. Start the inverter with the keypad or control terminal, and increase the load gradually. When the load is increased to 50% and 100%, keep the inverter run for a period respectively, to check if the system is running normally. Carry out overall inspection over the inverter during running, to check if there is any abnormality. In case of any abnormality, stop and check the inverter immediately.	
Checking during running	Check if the motor is running stable, if the rotary direction of the motor is correct, if there is any abnormal vibration or noise when the motor is running, if the acceleration/deceleration process of the motor is stable, if the output status of the inverter and the display of keypad panel is correct, if the blower fan is run normally, and if there is any abnormal vibration or noise. In case of any abnormality, stop the inverter immediately, and check the system after switching off the power supply.	

8-5 Operation and Simple Running

8.3 Illustration of Basic Operation

Illustration of inverter basic operation: we hereafter show various basic control operation processes by taking a 7.5kW inverter that drives a 7.5kW three-phase asynchronous AC motor as an example.

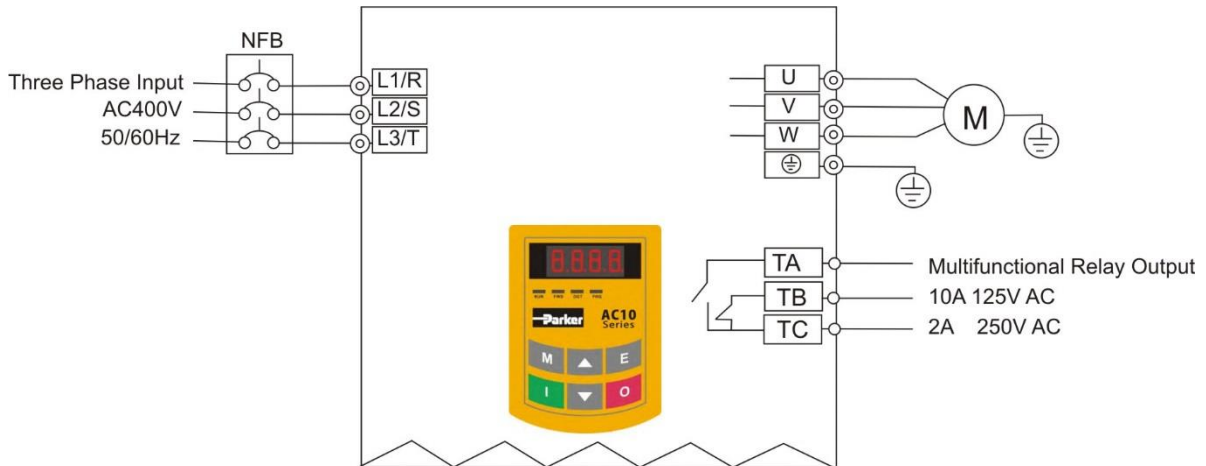

Figure 8-1 Wiring Diagram 1

The parameters indicated on the nameplate of the motor are as follows: 4 poles; rated power, 7.5kW; rated voltage, 400V; rated current, 15.4A; rated frequency 50.00HZ; and rated rotary speed, 1440rpm.

Frequency setting, start, forward running and stop using the keypad panel

- i. Connect the wires in accordance with Table 8-1. After having checked the wiring successfully, switch on the power to the inverter.
- ii. Press the “M” key, to enter the programming menu
- iii. Enter the parameters of the motor

Function code	Parameter	Values
F800	Autotune type	1(2)
F801	Rated motor power (kW)	7.5
F802	Rated motor voltage (V)	400
F803	Rated motor current (A)	15.4
F805	Base motor RPM	1440

Press the “I” key, to autotune the parameters of the motor. After completion of the tuning, the motor will stop running, and relevant parameters will be stored in F806~F809. For the details of tuning of motor parameters, please refer to “Operation process of measuring the motor parameters” in this manual.

Note: F800=1 is rotating tuning, F800=2 is stationary tuning. In the mode of rotating tuning, make sure to disconnect the motor from the load

- iv. Set functional parameters of the inverter:

Function code	Parameter	Values
F111	Maximum frequency	50.00
F200	Source of START	0
F201	Source of STOP	0
F202	Mode of direction setting	0
F203	Main frequency reference source	0

- v. Press the “I” key, to start the inverter;
- vi. During running, current frequency of the inverter can be changed by pressing ▲ or ▼;
- vii. Press the “O” key once, the motor will decelerate until it stops running;
- viii. Switch off the main switch, and power off the inverter.

8.3.2 Setting the frequency using the keypad panel, and starting, forward and reverse running, and stopping inverter through control terminals

- i. Connect the wires in accordance with **Figure 8-2**. After having checked the wiring successfully, switch on the main switch, and power on the inverter;

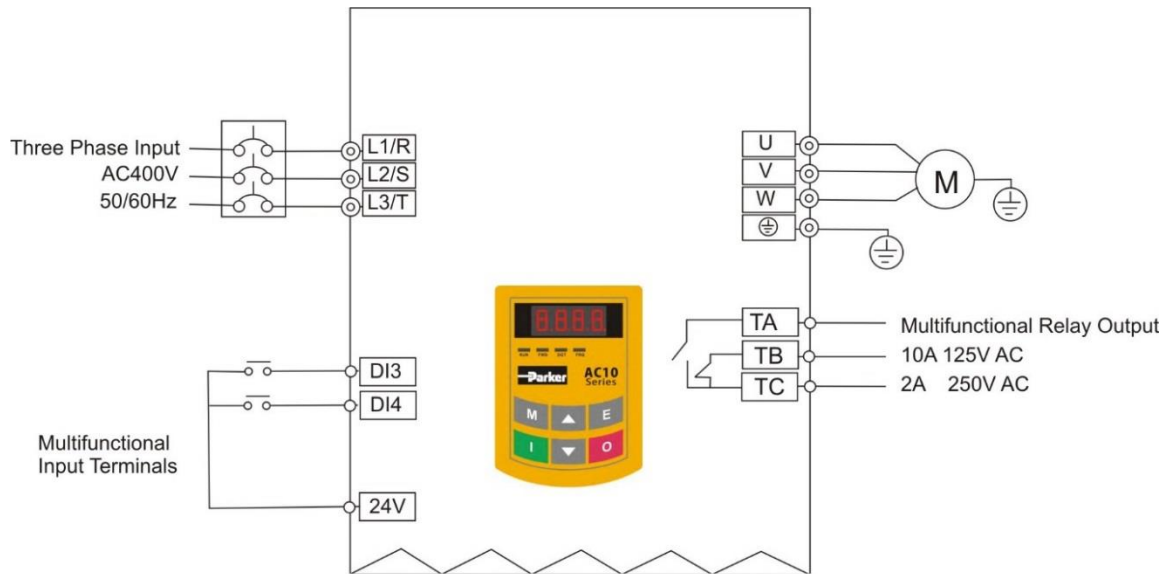

Figure 8-2 Wiring Diagram 2

- ii. Press the “M” key, to enter the programming menu.
- iii. Study the parameters of the motor: the operation process is the same as that of example 1. (Refer to 8.3.1 for tuning of the motor).
- iv. Set functional parameters of the inverter:

Function code	Parameter	Values
F111	Maximum frequency	50.00
F203	Main frequency source	0
F208	Terminal operational mode	1

- v. Close the switch DI3, the inverter starts forward running;
- vi. During running, current frequency of the inverter can be changed by pressing ▲ or ▼;
- vii. During running, switch off the switch DI3, then close the switch DI4, the running direction of the motor will be changed (Note: The user should set the dead time of forward and reverse running F120 on the basis of the load. If it was too short, OC protection of the inverter may occur.)
- viii. Switch off the switches DI3 and DI4, the motor will decelerate until it stops running;
- ix. Switch off the main switch to power off the inverter.

8.3.3 Operation process of jogging operation using the keypad panel

- i. Connect the wires in accordance with Figure 8-1. After having checked the wiring successfully, switch on the isolator, and power on the inverter;

8-7 Operation and Simple Running

- ii. Press the “M” key, to enter the programming menu.
- iii. Study the parameters of the motor: the operation process is the same as that of example 1. (Refer to 8.3.1 for tuning of the motor).
- iv. Set functional parameters of the inverter:

Function code	Parameter	Values
F124	Jogging frequency	5.00
F125	Jogging acceleration time	30
F126	Jogging deceleration time	30
F132	Display items for stop mode	1
F202	Direction setting mode	0

- v. Press and hold the “I” key until the motor is accelerated to the jogging frequency, and maintain the status of jogging operation.
- vi. Release the “I” key, or until motor reaches 0 speed;
- vii. Switch off the main switch to power off the inverter.

8.3.4 Setting the frequency with analog terminal and controlling the operation with control terminals

- i. Connect the wires in accordance with Figure 8-3. After having checked the wiring successfully, switch on the mains supply, and power on the inverter. Note: 2K~5K potentiometer may be used for setting external analog signals. For the cases with higher requirements for precision, a precise multiturn potentiometer is recommended, and adopt shielded wire for the wire connection, with near end of the shielding layer grounded reliably.

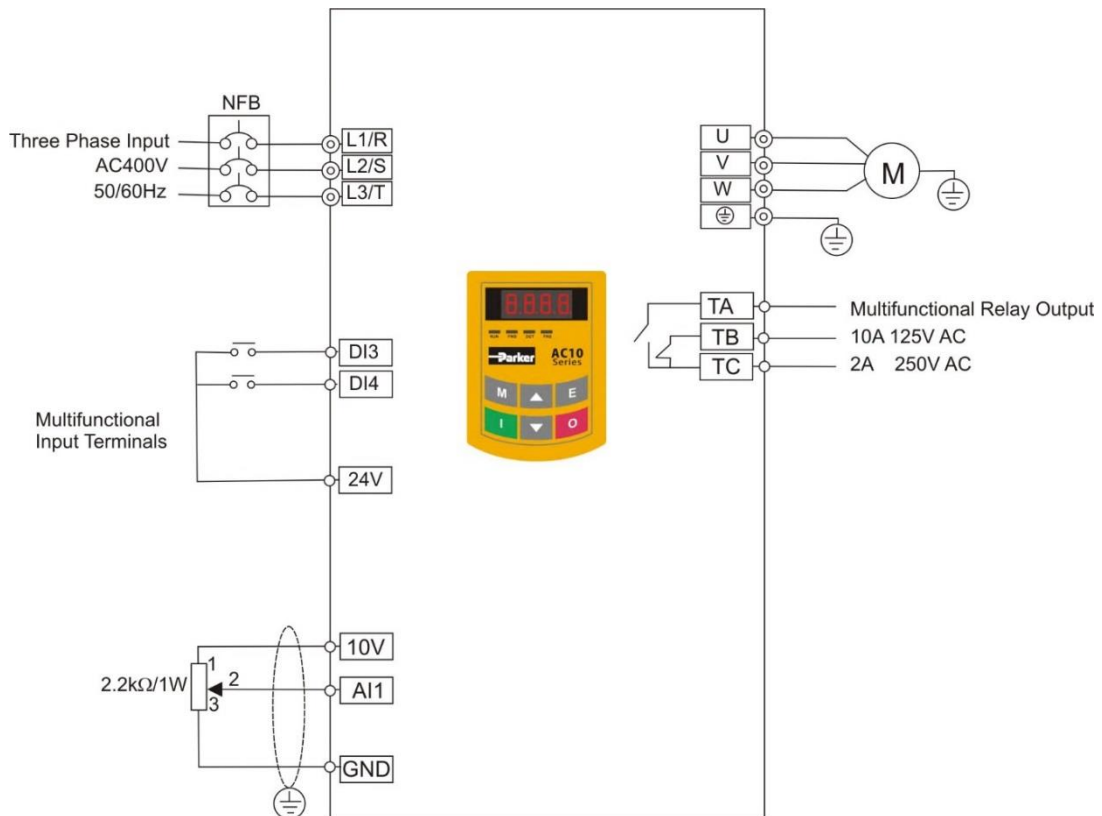

Figure 8-3 Wiring Diagram 3

- ii. Press the “M” key, to enter the programming menu.
- iii. Study the parameters of the motor: the operation process is the same as that of example 1. (Refer to 8.3.1 for tuning of the motor).
- iv. Set functional parameters of the inverter:

Function code	Parameter	Values
F203	Main frequency source	1
F208	Terminal operational mode	1

Frames 1 – 5 upto 22kW

- v. There is a red two-digit coding switch SW1 near the control terminal block, as shown in Figure 8-4. The function of coding switch is to select the voltage signal (0~5V/0~10V) or current signal of analog input terminal AI2, current channel is default. In actual application, select the analog input channel through F203. Turn switches 1 to ON and 2 to ON as illustrated in the figure, to select 0~20mA current speed control. Other states and modes of these switches are shown in table 8-2,

Frames 6 – 11 30kW – 150kW

- vi. There is a red four-digit coding switch SW1 near the control terminal block, as shown in Figure 8-5. The function of coding switch is to select the input range (0~5V/0~10V/0~20mA) of analog input terminal AI1 and AI2. In actual application, select the analog input channel through F203. AI1 channel default value is 0~10V, AI2 channel default value is 0~20mA. Other states and modes of these switches are shown in table 8-3.
- vii. There is a toggle switch S1 at the side of control terminals, refer to Fig 8-6. S1 is used to select the voltage input range of AI1 channel. When turning S1 to “+”, the input range is 0~10V, when turning S1 to “-”, the input range is -10~10V.
- viii. Close the switch DI3, the motor starts forward running;
- ix. The potentiometer can be adjusted and set during running, and the current setting frequency of the inverter can be changed;
- x. During running process, switch off the switch DI3, then, close DI4, the running direction of the motor will be changed;
- xi. Switch off the switches DI3 and DI4, the motor will decelerate until it stops running;
- xii. Switch off the main switch to power off the inverter.
- xiii. Analog output terminal AO1 can output voltage and current signal, the selecting switch is J5, refer to Fig 8-7 the output relation is shown in Table 8-4.

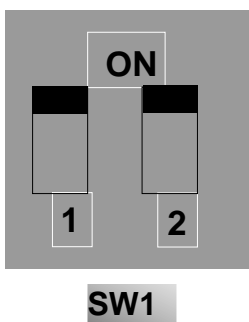

Figure 8-4

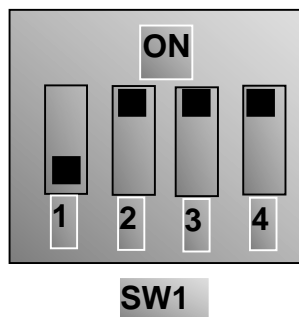

Figure 8-5

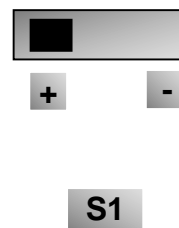

Figure 8-6

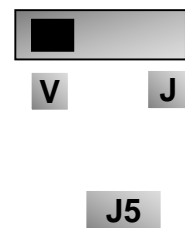

Figure 8-7

8-9 Operation and Simple Running

Table 8-2 The Setting of Coding Switch and Parameters for Analog Inputs

F203=2, channel AI2 is selected			F203=1, channel AI1 is selected	
SW1 coding switch			S1 toggle switch	
Coding Switch 1	Coding Switch 2	Analog Input AI2 signal	+	-
OFF	OFF	0~5V voltage	0 ~ 10V voltage	-10 ~ +10V voltage
OFF	ON	0~10V voltage		
ON	ON	0~20mA current		

Table 8-3 The Setting of Coding Switch and Parameters for Analog Inputs (in the Mode of Analog Speed Control).

Set F203 to 1, to select channel AI1				Set F203 to 2, to select channel AI2		
Coding Switch SW1		Toggle switch S1	Analog signal range	Coding Switch SW1		
Switch 1	Switch 3			Switch 2	Switch 4	Analog signal range
OFF	OFF	+	0~5V voltage	OFF	OFF	0~5V voltage
OFF	ON	+	0~10V voltage	OFF	ON	0~10V voltage
ON	ON	+	0~20mA current	ON	ON	0~20mA current
OFF	OFF	-	Reserved			
OFF	ON	-	-10~10V voltage			
ON	ON	-	Reserved			

ON refers to switching the coding switch to the top, OFF refers to switching the coding switch to the bottom

Table 8-4 The relationship between AO1 and J5 and F423

AO1 output		Setting of F423		
		0	1	2
J5	V	0~5V	0~10V	Reserved
	I	Reserved	0~20mA	4~20mA

Chapter 9 Function Parameters

9.1 Basic Parameters

F100	User's Password	Setting range: 0~9999	Mfr's value: 8
------	-----------------	--------------------------	----------------

When F107=1 with valid password, the user must enter correct user's password after power on or fault reset if you intend to change parameters. Otherwise, parameter setting will not be possible, and a prompt "Err1" will be displayed.

Relating function code: F107 Password valid or not F108 Setting user's password

F102	Inverter's Rated Current (A)		Mfr's value: Subject to inverter model
F103	Inverter Power (kW)		Mfr's value: Subject to inverter model

Rated current and rated power can only be checked but cannot be modified.

F105	Software Edition No.		Mfr's value: Subject to inverter model
------	----------------------	--	--

Software Edition No. can only be checked but cannot be modified.

F106	Control mode	Setting range: 0:Sensorless vector control (SVC); 1: Reserved; 2: V/F; 3: Vector control 1 6: PMSM sensorless vector control	Mfr's value: 2
------	--------------	---	----------------

0: Sensorless vector control is suitable for the application of high-performance requirement. One inverter can only drive one motor.

2: V/F control is suitable for common requirement of control precision or one inverter drives several motors.

3: Vector control 1 is auto torque promotion, which has the same function of F137=3. While studying motor parameters, motor does not need to be disconnected with load. One inverter can only drive one motor.

6: PMSM sensorless vector control is suitable for the application of high-performance requirement. One inverter can only drive one motor. Now 3ph 400V 0.75kW-90kW inverters can drive PMSM.

Note:

- It is necessary to autotune the drive before inverter runs in the sensorless vector control.
- Under sensorless vector control, one inverter can only drive one motor and the power of motor should be similar to the power of inverter. Otherwise, control performance will be decreased or the system cannot work properly.
- The operator may input motor parameters manually according to the motor parameters given by motor manufactures.
- Usually, the motor will work normally by inverter's default parameters, but the inverter's best control performance will not be acquired. Therefore, in order to get the best control performance autotune the drive before inverter runs in the sensorless vector control.

9-2 Function Parameters

F107 Password Valid or Not	Setting range: 0: invalid; 1: valid	Mfr's value: 0
F108 Setting User's Password	Setting range: 0~9999	Mfr's value: 8

When F107 is set to 0, the function codes can be changed without inputting the password.

When F107 is set to 1, the function codes can be changed only after inputting the user's password by F100.

The user can change "User's Password". The operation process is the same as those of changing other parameters.

Input the value of F108 into F100, and the user's password can be unlocked.

Note: When password protection is valid, and if the user's password is not entered, F108 will display 0.

F109 Starting Frequency (Hz)	Setting range: 0.00~10.00	Mfr's value: 0.00
F110 Holding Time of Starting Frequency (s)	Setting range: 0.0~999.9	Mfr's value: 0.0

The inverter begins to run from the starting frequency. If the target frequency is lower than starting frequency, F109 is invalid.

The inverter begins to run from the starting frequency. After it keeps running at the starting frequency for the time as set in F110, it will accelerate to target frequency. The holding time is not included in acceleration/deceleration time.

Starting frequency is not limited by the Min frequency set by F112. If the starting frequency set by F109 is lower than Min frequency set by F112, inverter will start according to the setting parameters set by F109 and F110. After inverter starts and runs normally, the frequency will be limited by frequency set by F111 and F112.

Starting frequency should be lower than Max frequency set by F111.

Note: When Flycatching is adopted, F109 and F110 are ignored.

F111 Max Frequency (Hz)	Setting range: F113~590.0	Mfr's value: 50.00
F112 Min Frequency (Hz)	Setting range: 0.00~F113	Mfr's value: 0.50

Max frequency is set by F111.

Min frequency is set by F112.

The setting value of min frequency should be lower than target frequency set by F113.

The inverter begins to run from the starting frequency. During inverter running, if the given frequency is lower than min frequency, then inverter will run at min frequency until inverter stops or given frequency is higher than min frequency.

Max/Min frequency should be set according to the nameplate parameters and running situations of motor. The motor should not run at low frequency for a long time, or else motor will be damaged because of overheating.

F113 Target Frequency (Hz)	Setting range: F112~F111	Mfr's value: 50.00
----------------------------	-----------------------------	--------------------

It shows the preset frequency. Under keypad speed control or terminal speed control mode, the inverter will run to this frequency automatically after startup.

F114	First Acceleration Time (s)	Setting range: 0.1~3000	Mfr's value: subject to inverter model
F115	First Deceleration Time (s)		
F116	Second Acceleration Time (s)		
F117	Second Deceleration Time (s)		
F277	Third Acceleration Time (S)		
F278	Third Deceleration Time (S)		
F279	Fourth Acceleration Time (S)		
F280	Fourth Deceleration Time (S)		

F119 is used to set the reference of setting acceleration/deceleration time.

The Acceleration/Deceleration time can be chosen by multifunction digital input terminals F316~F323 and connecting DI terminal with CM terminal. Please refer to the instructions of multifunctional input terminals.

Note: When Flycatching is working, acceleration/deceleration time, min frequency and target frequency are invalid. After Flycatching is finished, inverter will run to target frequency according to acceleration/deceleration time.

F118	Base Frequency (Hz)	Setting range: 15.00~590.0	Mfr's value: 50.00Hz
------	---------------------	-------------------------------	-------------------------

Base frequency is the frequency required to run the motor nameplate base speed (Typically 50Hz or 60Hz). Motor nameplate base speed (F805) = [(Base frequency x 120) / poles] – slip.

When running frequency is lower than this value, inverter has constant-torque output. When running frequency exceeds this value, inverter has constant-power output (i.e. Hp = SPEED x TORQUE).

Note: During the process of Flycatching, base frequency is ignored.

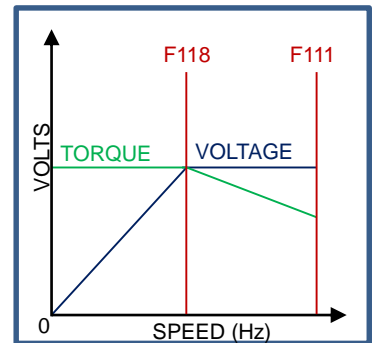

F119	The reference of setting accel/decel time	Setting range: 0: 0~50.00Hz 1: 0~F111	Mfr's value: 0
------	---	---	----------------

When F119=0, acceleration/deceleration time means the time for inverter to accelerate/ decelerate from 0Hz (50Hz) to 50Hz (0Hz).

When F119=1, acceleration/deceleration time means the time for inverter to accelerate/ decelerate from 0Hz (max frequency) to max frequency (0Hz).

F120	Forward / Reverse Switchover dead-Time (s)	Setting range: 0.0~3000	Mfr's value: 0.0
------	--	----------------------------	------------------

Within “forward/reverse switchover dead-time”, this latency time will be cancelled and the inverter will switch to run in the other direction immediately upon receiving “stop” signal. This function is suitable for all the speed control modes except automatic cycle operation.

This function can ease the current impact in the process of direction switchover.

Note: During the process of Flycatching, F120 is invalid. After Flycatching is finished, this function code is valid.

9-4 Function Parameters

F122 Reverse Running Forbidden	Setting range: 0: invalid; 1: valid	Mfr's value: 0
--------------------------------	---	----------------

When F122=1, inverter will only run forward no matter the state of terminals and the parameters set by F202.

Inverter will not run reverse and forward / reverse switchover is forbidden. If reverse signal is given, inverter will stop.

If reverse running locking is valid (F202=1), inverter has no output.

When F122=1, F613=1, F614≥2 and inverter gets forward running command and motor is rotating in reverse, the inverter will run to 0.0Hz reverse, then run forward according to the setting value of parameters.

If reverse running locking is valid (F202=1), whatever Flycatching is valid or not, inverter has no output.

When F122=1, F613=1, F614≥2 and inverter gets forward running command and motor is sliding reverse, if inverter can detect the sliding direction and track to motor speed, then inverter will run to 0.0Hz reverse, then run forward according to the setting value of parameters.

F123 Minus frequency is valid in the mode of combined speed control.	0: False 1: True	0
--	---------------------	---

In the mode of combined speed control, if running frequency is minus and F123=0, inverter will run at 0Hz; if F123=1, inverter will run reverse at this frequency. (This function is controlled by F122.)

F124 Jogging Frequency (Hz)	Setting range: F112~F111	Mfr's value: 5.00Hz
F125 Jogging Acceleration Time (s)	Setting range: 0.1~3000	Mfr's value: subject to inverter model
F126 Jogging Deceleration Time (s)		

There are two types of jogging: keypad jogging and terminal jogging. Keypad jogging is valid only under stopped status (F132 including of displaying items of keypad jogging should be set). Terminal jogging is valid under both running status and stopped status. Carry out jogging operation through the keypad (under stopped status):

(a) Press the "M" key, it will display "HF-0";

(b) Press the "I" key, the inverter will run to "jogging frequency" (if pressing "M" key again, "keypad jogging" will be cancelled).

Jogging Acceleration Time: the time for inverter to accelerate from 0Hz to 50Hz.

Jogging Deceleration Time: the time for inverter to decelerate from 50Hz to 0Hz.

In case of terminal jogging, make "jogging" terminal (such as DI1) connected to CM, and inverter will run to jogging frequency. The rated function codes are from F316 to F323.

Note: When jogging function is valid, Flycatching function is invalid.

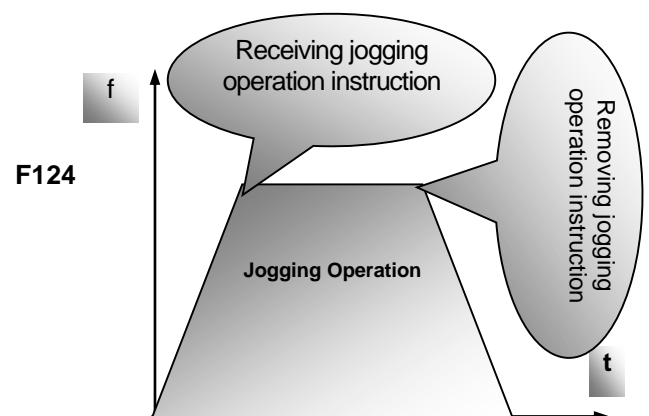

Figure 9-1 Jogging Operation

F127/F129	Skip Frequency A,B (Hz)	Setting range: 0.00~590.0	Mfr's value:0.00Hz
F128/F130	Skip Width A,B (Hz)	Setting range: ±2.5	Mfr's value: 0.0

Systematic vibration may occur when the motor is running at a certain frequency. This parameter is set to skip this frequency.

The inverter will skip the point automatically when output frequency is equal to the set value of this parameter.

“Skip Width” is the span from the upper to the lower limits around Skip Frequency. For example, Skip Frequency=20Hz, Skip Width=±0.5Hz, inverter will skip automatically when output is between 19.5~20.5Hz.

The inverter will not skip this frequency span during acceleration/deceleration.

Note: During the process of Flycatching, skip frequency function is invalid. After Flycatching is finished, this function is valid.

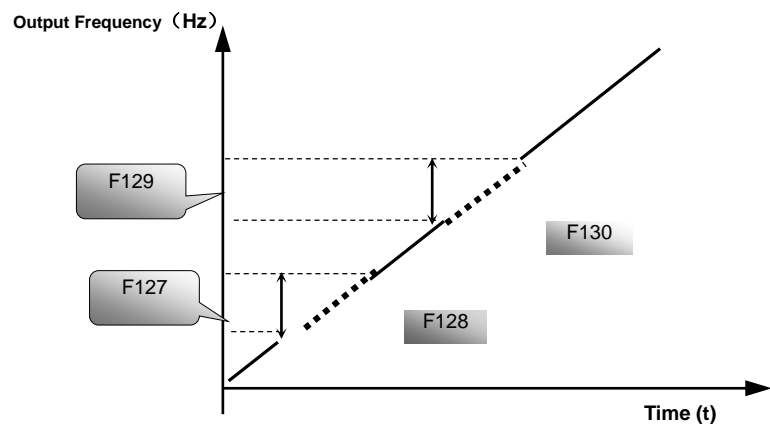

Figure 9-2 Skip Frequency

F131 Running Display Items	0— Current output frequency/function-code 1— Output rotary speed 2— Output current 4— Output voltage 8— DC Bus Voltage 16— PID feedback value 32— Temperature 64— Reserved 128— Linear speed 256— PID given value 512— Reserved 1024— Reserved 2048— Output power 4096— Output torque	Mfr's value: 0+1+2+4+8=15
----------------------------	--	------------------------------

Selection of one value from 1, 2, 4, 8, 16, 32, 64 and 128 shows that only one specific display item is selected. Should multiple display items be intended, add the values of the corresponding display items and take the total values as the set value of F131, e.g., just set F131 to be 19 (1+2+16) if you want to call “current output rotary speed”, “output current” and “PID feedback value”. The other display items will be covered.

As F131=8191, all display items are visible, of which, “frequency/function-code” will be visible whether or not it is selected.

Should you intend to check any display item, press the “M” key for switchover.

Refer to the following table for each specific value unit and its indication:

9-6 Function Parameters

Whatever the value of F131 is set to, corresponding target frequency will flash under stopped status.

Target rotary speed is an integral number. If it exceeds 9999, add a decimal point to it.

Keypad Displays					
Current	A*.*	DC Bus Voltage	U***	Output Voltage	u***
Temperature	H***	Linear Speed	L***		
PID Reference	O*.*	PID Feedback	B*.*		
Output power	*.*	Output torque	*.*		

If it exceeds 999, add a decimal point to it.

If it exceeds 9999, add two decimal points to it, and the like.

F132	Display items of stop	Setting range: 0: Frequency/function-code 1: Keypad jogging 2: Target rotary speed 4: DC Bus Voltage 8: PID feedback value 16: Temperature 32: Reserved 64: PID given value 128: Reserved 256: Reserved 512: Setting torque	Mfr's value: 0+2+4=6
F133	Drive ratio of driven system	Setting range: 0.10~200.0	Mfr's value:
F134	Transmission-wheel radius	0.001~1.000 (m)	Mfr's value: 0.001

Calculation of rotary speed and linear speed:

For example, If inverter's max frequency F111=50.00Hz, numbers of motor poles F804=4, drive ratio F133=1.00, transmission-shaft radius R=0.05m, then

Transmission shaft perimeter: $2\pi R = 2 \times 3.14 \times 0.05 = 0.314$ (meter)

Transmission shaft rotary speed: $60 \times \text{operation frequency} / (\text{numbers of poles pairs} \times \text{drive ratio}) = 60 \times 50 / (2 \times 1.00) = 1500 \text{rpm}$

Maximum linear speed: rotary speed \times perimeter = $1500 \times 0.314 = 471$ (meters/second)

F136	Slip compensation	Setting range: 0~10	Mfr's value: 0
------	-------------------	---------------------	----------------

Under V/HZ controlling, rotary speed of motor rotor will decrease as load increases. Be assured that rotor rotate speed is near to synchronization rotary speed while motor with rated load, slip compensation should be adopted according to the setting value of frequency compensation.

Note: During the process of Flycatching, slip compensation function is invalid. After Flycatching is finished, this function is valid.

F137	Modes of torque compensation	Setting range: 0: Linear compensation; 1: Square compensation; 2: User-defined multipoint compensation 3: Auto torque compensation	Mfr's value: 3
F138	Linear compensation	Setting range: 1~20	Mfr's value: subject to inverter model
F139	Square compensation	Setting range: 1: 1.5 2: 1.8 3: 1.9 4: 2.0	Mfr's value: 1

When F106 (Control Mode) = 2, the function of F137 is enabled.

To compensate low-frequency torque controlled by V/HZ, output voltage of inverter while low-frequency should be compensated.

When F137=0, linear compensation is chosen and it is applied on universal constant-torque load;

When F137=1, square compensation is chosen and it is applied on the loads of fan or water pump;

When F137=2, user-defined multipoint compensation is chosen and it is applied on the special loads of spin-drier or centrifuge;

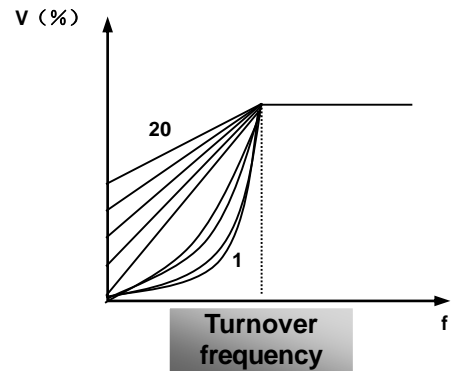

Figure 9-3 Torque Promotion

This parameter should be increased when the load is heavier, and this parameter should be decreased when the load is lighter.

If the torque is elevated too much, the motor overheats easily, and the current of inverter will be too high. Please check the motor while elevating the torque.

When F137=3, auto torque compensation is chosen and it can compensate low-frequency torque automatically, to diminish motor slip, to make rotor rotary speed close to synchro rotary speed and to restrain motor vibration. Customers should correctly set motor power, rotary speed, numbers of motor poles, motor rated current and stator resistance. Please refer to the chapter "Operation process of measuring motor parameters".

F140	Voltage compensation point frequency (Hz)	Setting range: 0~F142	Mfr's value: 1.00
F141	Voltage compensation point 1 (%)	Setting range: 0~100%	Subject to inverter model
F142	User-defined frequency point F2	Setting range: F140~F144	Mfr's value:
F143	User-defined voltage point V2	Setting range: 0~100%	Mfr's value: 13
F144	User-defined frequency point F3	Setting range: F142~F146	Mfr's value:
F145	User-defined voltage point V3	Setting range: 0~100%	Mfr's value: 24
F146	User-defined frequency point F4	Setting range: F144~F148	Mfr's value:
F147	User-defined voltage point V4	Setting range: 0~100%	Mfr's value: 45
F148	User-defined frequency point F5	Setting range: F146~F150	Mfr's value:
F149	User-defined voltage point V5	Setting range: 0~100%	Mfr's value: 63
F150	User-defined frequency point F6	Setting range: F148~F118	Mfr's value:
F151	User-defined voltage point V6	Setting range: 0~100%	Mfr's value: 81

Multi-stage V/HZ curves are defined by 12 parameters from F140 to F151.

9-8 Function Parameters

The setting value of V/Hz curve is set by motor load characteristic.

Note: $V1 < V2 < V3 < V4 < V5 < V6$, $F1 < F2 < F3 < F4 < F5 < F6$. As with low-frequency, if the voltage setting is too high, the motor will overheat or be damaged. Inverter will be stalling or occur over-current protection.

Note: During the process of Flycatching, polygonal-line V/Hz curve function is disabled. After Flycatching is finished, this function is enabled.

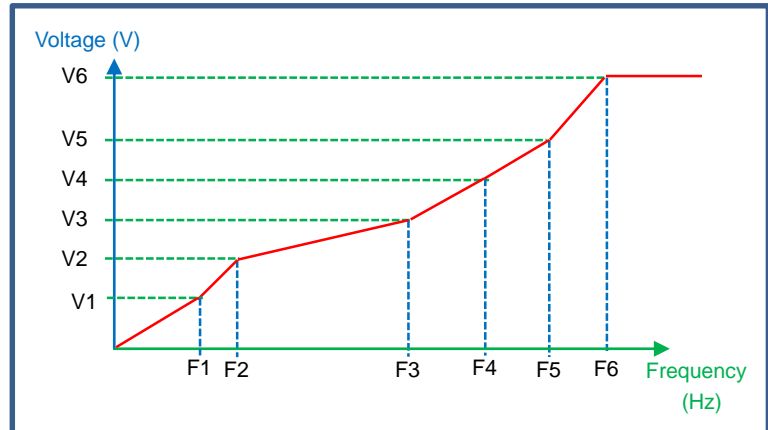

Figure 9-4 Polygonal-Line Type V/Hz

F152 Output voltage corresponding to turnover frequency	Setting range: 0~100	Mfr's value: 100
---	----------------------	------------------

This function can meet the needs of some special loads, for example, when the frequency outputs 300Hz and corresponding voltage outputs 200V (supposed voltage of inverter power supply is 400V), turnover frequency F118 should be set to 300Hz and F152 is set to $(200 \div 400) \times 100 = 50$. And F152 should be equal to 50.

CAUTION: Please pay attention to nameplate parameters of motor. If the motor is not rated as inverter-duty; if the inverter output voltage is higher than rated voltage of the motor windings; or if the inverter output volts-per-hertz ratio is not the same as the motor specifications, the motor will be damaged.

F153 Carrier frequency setting	Setting range: subject to inverter model	Mfr's value: subject to inverter model
--------------------------------	--	--

Carrier-wave frequency of inverter is adjusted by setting this code function. Adjusting carrier-wave may reduce motor noise, avoid point of resonance of mechanical system, decrease leakage current of wire to earth and the interference of inverter.

When carrier-wave frequency is low, although carrier-wave noise from motor will increase, the current leaked to the earth will decrease. The wastage of motor and the temperature of motor will increase, but the temperature of inverter will decrease.

When carrier-wave frequency is high, the situations are opposite, and the interference will raise.

When output frequency of inverter is adjusted to high frequency, the setting value of carrier-wave should be increased. Performance is influenced by adjusting carrier-wave frequency as below table:

Carrier-wave frequency	Low	→	High
Motor noise	Loud	→	Low
Waveform of output current	Bad	→	Good
Motor temperature	High	→	Low
Inverter temperature	Low	→	High
Leakage current	Low	→	High
Interference	Low	→	High

F154 Automatic voltage rectification	Setting range: 0: Invalid 1: Valid 2: Invalid during deceleration process	Mfr's value: 0
--------------------------------------	--	----------------

This function is enabled to keep output voltage constant automatically in the case of fluctuation of input voltage, but the deceleration time will be affected by internal PI adjustor. If deceleration time is forbidden being changed, please select F154=2.

F155 Digital secondary frequency setting	Setting range: 0~F111	Mfr's value: 0
F156 Digital secondary frequency polarity setting	Setting range: 0 or 1	Mfr's value: 0
F157 Reading secondary frequency		
F158 Reading secondary frequency polarity		

Under combined speed control mode, when secondary frequency source is digital setting memory (F204=0), F155 and F156 are considered as initial set values of secondary frequency and polarity (direction).

In the mode of combined speed control, F157 and F158 are used for reading the value and direction of secondary frequency.

For example, when F203=1, F204=0. F207=1, the given analog frequency is 15Hz, inverter is required to run to 20Hz. In case of this requirement, user can push "UP" button to raise the frequency from 15Hz to 20Hz. User can also set F155=5Hz and F156=0 (0 means forward, 1 means reverse). In this way, inverter can be run to 20Hz directly.

F159 Random carrier-wave selection	Setting range: 0: Control speed normally 1: Random carrier-wave frequency	Subject to inverter model
------------------------------------	---	---------------------------

When F159=0, inverter will modulate as per the carrier-wave set by F153. When F159=1, inverter will operate in mode of random carrier-wave modulating.

Note: when random carrier-wave is selected, output torque will increase but noise will be loud. When the carrier-wave set by F153 is selected, noise will be reduced, but output torque will decrease. Please set the value according to the situation.

F160 Reverting to manufacturer values	Setting range: 0: Invalid 1: Valid	Mfr's value: 0
---------------------------------------	--	----------------

When there is problem with inverter's parameters and manufacturer values need to be restored, set F160=1. After "Reverting to manufacturer values" is done, F160 values will be automatically changed to 0.

"Reverting to manufacturer values" will not work for the function-codes marked "o" in the "change" column of the parameters table. These function codes have been adjusted properly before delivery. It is recommended not to change them.

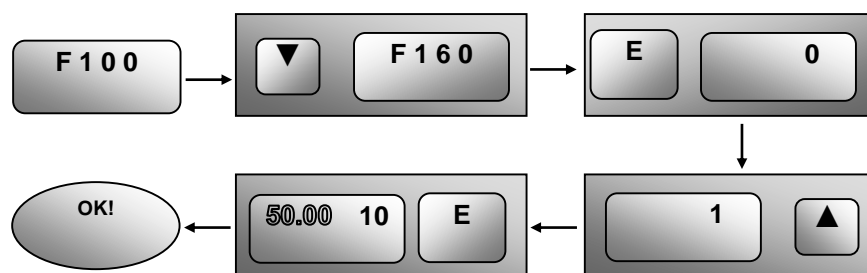

Figure 9-5 Reverting to Manufacturer Values

9-10 Function Parameters

9.2 Operation Control

F200 Source of start command	Setting range: 0: Keypad command; 1: Terminal command; 2: Keypad+Terminal; 3: MODBUS; 4: Keypad+Terminal+MODBUS	Mfr's value: 4
F201 Source of stop command	Setting range: 0: Keypad command; 1: Terminal command; 2: Keypad+Terminal; 3: MODBUS; 4: Keypad+Terminal+MODBUS	Mfr's value: 4

F200 and F201 are the resource of selecting inverter control commands.

Inverter control commands include: starting, stopping, forward running, reverse running, jogging, etc.

"Keypad command" refers to the start/stop commands given by the "I" or "O" key on the keypad.

"Terminal command" refers to the start/stop command given by the "I" terminal defined by F316-F323.

When F200=3 and F201=3, the running command is given by MODBUS communication.

When F200=2 and F201=2, "keypad command" and "terminal command" are valid at the mean time, F200=4 and F201=4 are the same.

F202 Mode of direction setting	Setting range: 0: Forward running locking; 1: Reverse running locking; 2: Terminal setting 3: Keypad	Mfr's value: 0
-----------------------------------	--	-------------------

The running direction is controlled by this function code together with other speed control mode which can set the running direction of inverter. When auto-circulation speed is selected by F500=2, this function code is not valid.

When speed control mode without controlling direction is selected, the running direction of inverter is controlled by this function code, for example, keypad controls speed.

Direction given by F202	Direction given by other control mode	Running direction	Remarks
0	0	0	0 means forward. 1 means reverse.
0	1	1	
1	0	1	
1	1	0	

F203 Main frequency source X	Setting range: 0: Memory of digital given;(adjust with keypad) 1: External analog AI1; 2: External analog AI2; 3: Reserved; 4: Stage speed control; 5: No memory of digital given; 6: Reserved; 7: Reserved; 8: Reserved; 9: PID adjusting; 10: MODBUS	Mfr's value: 0
---------------------------------	---	----------------

Main frequency source is set by this function code.

0: Memory of digital given

Its initial value is the value of F113. The frequency can be adjusted through the keypad "up" or
AC10 Inverter

“down”, or through the “up”, “down” terminals.

“Memory of digital given” means after inverter stops, the target frequency is the running frequency before stop. If the user would like to save target frequency in memory when the power is disconnected, please set F220=1, i.e. frequency memory after power down is valid.

1: External analog AI1; **2:** External analog AI2

The frequency is set by analog input terminal AI1 and AI2. The analog signal may be current signal (0-20mA or 4-20mA) or voltage signal (0-5V or 0-10V), which can be chosen by switch code. Please adjust the switch code according to practical situations, refer to fig 4-4 and Table 8-2.

When inverters leave the factory, the analog signal of AI1 channel is DC voltage signal, the range of voltage is 0-10V, and the analog signal of AI2 channel is DC current signal, the range of current is 0-20 mA. If 4-20mA current signal is needed, please set lower limit of analog input F406=2, which input resistor is 500OHM. If some errors exist, please make some adjustments.

4: Stage speed control

Multi-stage speed control is selected by setting stage speed terminals F316-F322 and function codes of multi-stage speed section. The frequency is set by multi-stage terminal or automatic cycling frequency.

5: No memory of digital given

Its initial value is the value of F113. The frequency can be adjusted through the key “up” or “down”, or through the “up”, “down” terminals.

“No memory of digital given” means that the target frequency will restore to the value of F113 after stop no matter the state of F220.

9: PID adjusting

When PID adjusting is selected, the running frequency of inverter is the value of frequency adjusted by PID. Please refer to instructions of PID parameters for PID given resource, PID given numbers, feedback source, and so on.

10: MODBUS

The main frequency is given by MODBUS communication.

F204 Secondary frequency source Y	Setting range: 0: Memory of digital given; (adjust with keypad) 1: External analog AI1; 2: External analog AI2; 3: Reserved; 4: Stage speed control; 5: PID adjusting; 6: Reserved;	Mfr's value: 0
-----------------------------------	--	----------------

When secondary frequency Y is given to channel as independent frequency, it has the same function with main frequency source X.

When F204=0, the initial value of secondary frequency is set by F155. When secondary frequency controls speed independently, polarity setting F156 is not valid.

When F207=1 or 3, and F204=0, the initial value of secondary frequency is set by F155, the polarity of frequency is set by F156, the initial value of secondary frequency and the polarity of secondary frequency can be checked by F157 and F158.

When the secondary frequency is set by analog input (AI1, AI2), the setting range for the frequency is set by F205 and F206.

When the secondary frequency is given by keypad potentiometer, the main frequency can only select stage speed control and modbus control (F203=4, 10)

Note: secondary frequency source Y and main frequency source X cannot use the same frequency given channel.

9-12 Function Parameters

F205 reference for selecting secondary frequency source Y range	Setting range: 0: Relative to max frequency; 1: Relative to main frequency X	Mfr's value: 0
F206 secondary frequency Y range (%)	Setting range: 0~100	Mfr's value: 100

When combined speed control is adopted for frequency source, F206 is used to confirm the relative object of the setting range for the secondary frequency.

F205 is to confirm the reference of the secondary frequency range. If it is relative to main frequency, the range will change according to the change of main frequency X.

F207 Frequency source selecting	Setting range: 0: X; 1: X+Y; 2: X or Y (terminal switchover); 3: X or X+Y (terminal switchover); 4: Combination of stage speed and analog 5: X-Y 6: Reserved	Mfr's value: 0
---------------------------------	---	----------------

Select the channel of setting the frequency. The frequency is given by combination of main frequency X and secondary frequency Y.

When F207=0, the frequency is set by main frequency source.

When F207=1, X+Y, the frequency is set by adding main frequency source to secondary frequency source. X or Y can be given by PID.

When F207=2, main frequency source and secondary frequency source can be switched over by frequency source switching terminal.

When F207=3, main frequency given and adding frequency given(X+Y) can be switched over by frequency source switching terminal. X or Y cannot be given by PID.

When F207=4, stage speed setting of main frequency source has priority over analog setting of secondary frequency source (only suitable for F203=4 F204=1).

When F207=5, X-Y, the frequency is set by subtracting secondary frequency source from main frequency source. If the frequency is set by main frequency or secondary frequency, PID speed control cannot be selected.

Note:

When F203=4 and F204=1, the difference between F207=1 and F207=4 is that when F207=1, frequency source selecting is the addition of stage speed and analog, when F207=4, frequency source selecting is stage speed with stage speed and analog given at the same time. If stage speed given is cancelled and analog given still exists, inverter will run by analog given.

Frequency given mode can be switched over by selecting F207. For example: switching PID adjusting and normal speed control, switching stage speed and analog given, switching PID adjusting and analog given, and so on.

The acceleration/deceleration time of stage speed is set by function code of corresponding stage speed time. When combined speed control is adopted for frequency source, the acceleration/deceleration time is set by F114 and F115.

The mode of automatic cycle speed control is unable to combine with other modes.

When F207=2 (main frequency source and secondary frequency source can be switched over by terminals), if main frequency is not set to be under stage-speed control, secondary frequency can be set to be under automatic cycle speed control (F204=5, F500=0). Through the defined switchover terminal, the control mode (defined by X) and automatic cycle speed control (defined by Y) can be freely switched.

If the settings of main frequency and secondary frequency are the same, only main frequency will be valid.

<p>F208 Terminal two-line/three-line operation control</p>	<p>Setting range: 0: No function 1: Two-line operation mode 1; 2: Two-line operation mode 2; 3: three-line operation mode 1; 4: three-line operation mode 2; 5: start/stop controlled by direction pulse</p>	<p>Mfr's value: 0</p>
--	--	-----------------------

When selecting two-line type or three-line type), F200, F201 and F202 are invalid.

Five modes are available for terminal operation control.

Note: In case of stage speed control, set F208 to 0. If F208 ≠ 0 (when selecting two-line type or three-line type), F200, F201 and F202 are invalid.

“FWD”, “REV” and “X” are three terminals designated in programming DI1 ~ DI5.

1: Two-line operation mode 1: this mode is the most popularly used two-line mode. The running direction of mode is controlled by FWD, REV terminals.

For example: “FWD” terminal -----“open”: stop, “closed”: forward running;

“REV” terminal -----“open”: stop, “closed”: reverse running;

“CM” terminal -----common port

K1	K2	Running command
0	0	Stop
1	0	Forward running
0	1	Reverse running
1	1	Stop

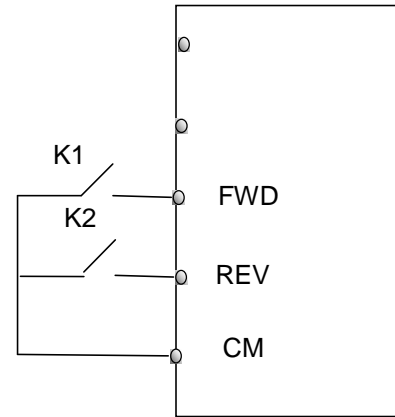

2: Two-line operation mode 2: when this mode is used, FWD is enable terminal, the direction is controlled by REV terminal.

For example: “FWD” terminal -----“open”: stop, “closed”: running;

“REV” terminal -----“open”: forward running, “closed”: reverse running;

“CM” terminal -----common port

K1	K2	Running command
0	0	Stop
0	1	Stop
1	0	Forward running
1	1	Reverse running

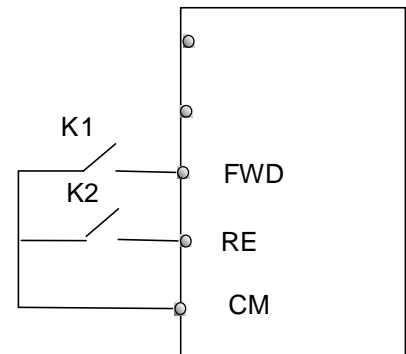

9-14 Function Parameters

3: Three-line operation mode 1:

In this mode, X terminal is enable terminal, the direction is controlled by FWD terminal and REV terminal. Pulse signal is valid.

Stopping commands is enabled by opening X terminal.

SB3: Stop button

SB2: Forward button

SB1: Reverse button

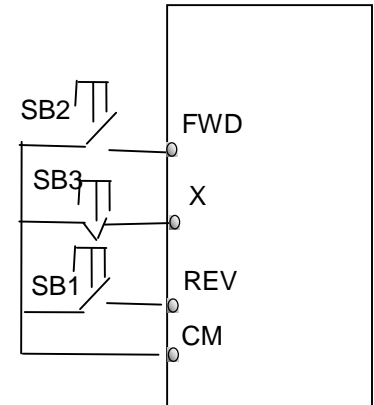

4: Three-line operation mode 2:

In this mode, X terminal is enable terminal, running command is controlled by FWD terminal. The running direction is controlled by REV terminal, and stopping command enable by opening X terminal.

SB1: Running button

SB2: Stop button

K1: direction switch. Open stands for forward running; close stands for reverse running.

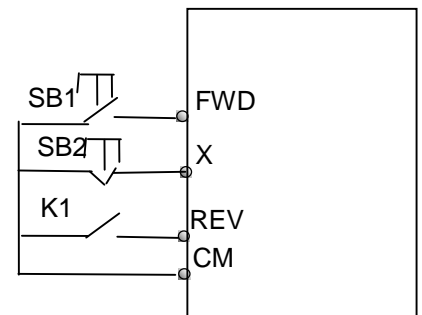

5: Start/stop controlled by direction pulse:

“FWD” terminal—(impulse signal: forward/stop)

“REV” terminal—(impulse signal: reverse/stop)

“CM” terminal—common port

Note: when pulse of SB1 triggers, inverter will run forward. When the pulse triggers again, inverter will stop running.

When pulse of SB2 triggers, inverter will run reverse. When the pulse triggers again, inverter will stop running.

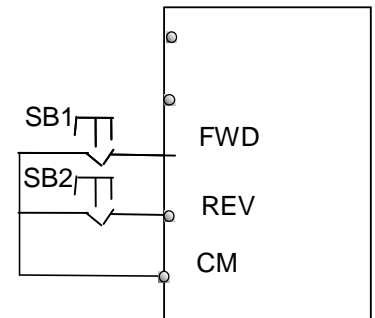

F209 Selecting the mode of stopping the motor	Setting range: 0: stop by deceleration time; 1: free stop(coast stop)	Mfr's value: 0
---	---	----------------

When the stop signal is input, stopping mode is set by this function code:

F209=0: stop by deceleration time

Inverter will decrease output frequency according to setting acceleration/deceleration curve and decelerating time, after frequency decreases to 0, inverter will stop.

F209=1: free stop

After stop command is valid, inverter will stop output. Motor will free stop by mechanical inertia.

Function Parameters 9-15

F210 Frequency display accuracy	Setting range: 0.01~2.00	Mfr's value: 0.01
---------------------------------	-----------------------------	-------------------

Under keypad speed control or terminal UP/DOWN speed control, frequency display accuracy is set by this function code and the range is from 0.01 to 2.00. For example, when F210=0.5, ▲/▼ terminal is pressed at one time, frequency will increase or decrease by 0.5Hz.

F211 Speed of digital control	Setting range: 0.01~100.0Hz/S	Mfr's value: 5.00
-------------------------------	----------------------------------	-------------------

When UP/DOWN terminal is pressed, frequency will change at the setting rate. The Mfr's value is 5.00Hz/s.

F212 Direction memory	Setting range: 0: Disable 1: Enable	Mfr's value: 0
-----------------------	---	----------------

This function is valid when three-line operation mode 1 (F208=3) is valid.

When F212=0, after inverter is stopped, reset and repowered on, the running direction is not memorized.

When F212=1, after inverter is stopped, reset and repowered on, if inverter starts running but no direction signal, inverter will run according the memory direction.

F213 Auto-starting after repowered on	Setting range: 0: Disable 1: Enable	Mfr's value: 0
F214 Auto-starting after reset	Setting range: 0: Disable 1: Enable	Mfr's value: 0

Whether or not to start automatically after repowered on is set by F213

F213=1, Auto-starting after repowered on is valid. When inverter is power off and then powered on again, it will run automatically after the time set by F215 and according to the running mode before power-down. If F220=0 frequency memory after power-down is not valid, inverter will run by the setting value of F113.

F213=0, after repower-on, inverter will not run automatically unless running command is given to inverter.

Whether or not to start automatically after fault resetting is set by F214

When F214=1, if fault occurs, inverter will reset automatically after delay time for fault reset (F217). After resetting, inverter will run automatically after the auto-starting delay time (F215).

If frequency memory after power-down (F220) is valid, inverter will run at the speed before power-down. Otherwise, inverter will run at the speed set by F113.

In case of fault under running status, inverter will reset automatically and auto-start. In case of fault under stopped status, the inverter will only reset automatically.

When F214=0, after fault occurs, inverter will display fault code, it must be reset manually.

F215 Auto-starting delay time	Setting range: 0.1~3000.0	Mfr's value: 60.0
-------------------------------	------------------------------	-------------------

F215 is the auto-starting delay time for F213 and F214. The range is from 0.1s to 3000.0s.

9-16 Function Parameters

F216 Auto-start restart attempts	Setting range: 0~5	Mfr's value: 0
F217 Fault reset delay	Setting range: 0.0~10.0	Mfr's value: 3.0

F216 sets the most times of auto-starting in case of repeated faults. If starting times are more than the setting value of this function code, inverter will not reset or start automatically after fault. Inverter will run after running command is given to inverter manually.

F217 sets delay time for fault reset. The range is from 0.0 to 10.0s which is time interval from fault to resetting.

F219 Write EEPROM by Modbus	Setting range: 0: Disable 1: Enable	Mfr's value: 1
F220 Frequency memory after power-down	Setting range: 0: Disable 1: Enable	Mfr's value: 0

F220 sets whether or not frequency remember after power-down is valid.

This function is valid for F213 and F214. Whether or not to memory running state after power-down or malfunction is set by this function.

The function of frequency memory after power-down is valid for main frequency and secondary frequency that is given by digital. Because the digital given secondary frequency has positive polarity and negative polarity, it is saved in the function codes F155 and F156.

Table 9-1 Combination of Speed Control

F203 \ F204	0. Memory of digital setting	1 External analog AI1	2 External analog AI2	4 Terminal stage speed control	5 PID adjusting
0 Memory of digital setting	○	●	●	●	●
1 External analog AI1	●	○	●	●	●
2 External analog AI2	●	●	○	●	●
4 Terminal Stage speed control	●	●	●	○	●
5 Digital setting	○	●	●	●	●
9 PID adjusting	●	●	●	●	○
10 MODBUS	●	●	●	●	●

●: Inter-combination is allowable.

○: Combination is not allowable.

The mode of automatic cycle speed control is unable to combine with other modes. If the combination includes the mode of automatic cycle speed control, only main speed control mode will be valid.

F224 when target frequency is lower than Min frequency	Setting range: 0: stop 1: run at min frequency	Mfr's value: 1
--	--	----------------

F224=1, when target frequency is lower than Min frequency, inverter will run at Min frequency.

F228 Application selection	Setting range: 0: None 1: Basic speed control 2: Auto/manual speed control 3: Preset speed control 4: Terminal speed control 5: PID control	Mfr's value: 0
----------------------------	---	----------------

·F228 can be set to Mfr's value by F160=1.

9.3 Multifunctional Input and Output Terminals

9.3.1 Digital multifunctional output terminals

F300 Relay token output	Setting range: 0~40	Mfr's value: 1
F301 DO1 token output	Refer to Table 9-2 for detailed instructions.	Mfr's value: 14
F302 DO2 token output		Mfr's value: 5

Table 9-2 Instructions for digital multifunctional output terminal

Value	Function	Instructions
0	No function	Output terminal has no functions.
1	Inverter fault protection	When inverter trips this signal is output high.
2	At target frequency 1	Please refer to instructions from F307 to F309.
3	At target frequency 2	Please refer to instructions from F307 to F309.
4	Free stop	Under free stop (coast stop) status, after stop command is given, the output is true until inverter completely stops.
5	In running status 1	When the inverter is running, the output is true.
6	DC braking	When the DC braking and run are true, the output is true.
7	Acceleration/deceleration time switchover	When the inverter is in the state of acceleration/deceleration time switchover, the output is true.
8	Reserved	
9	Reserved	
10	Inverter overload pre-alarm	When the inverter load reaches the Overload pre-alarm Coefficient (F704) for half the timed protection, the output is true. The output becomes false after the inverter load falls below F704 or an inverter overload fault occurs.

9-18 Function Parameters

Value	Function	Instructions
11	Motor overload pre-alarm	After motor overloads, ON signal is output after the half time of protection timed, ON signal stops outputting after overload stops or overload protection occurs.
12	Stalling	During accel/decel process, inverter stops accelerating/decelerating because inverter is stalling, and ON signal is output.
13	Inverter is ready to run	When inverter is powered on. Protection function is not in action and inverter is ready to run, then ON signal is output.
14	In running status 2	Indicating that inverter is running and ON signal is output. When inverter is running at 0HZ, its seen as the running status, and ON signal is output.
15	Frequency arrival output At Speed	Indicating inverter runs at the setting target frequency, and ON signal is output. See F312.
16	Overheat pre-alarm Warning	When temperature reaches 80% of setting value, the output is true until overheat protection occurs or temperature is lower than 80% of setting value, then the output becomes false.
17	Over latent current output	When output current of inverter reaches the setting over latent current, ON signal is output. See F310 and F311.
18	Analog line disconnection protection	Indicating inverter detects analog input lines disconnection, and ON signal is output refer to F741.
19	Reserved	
20	At zero output current	When inverter output current has fallen to zero current detecting value, and the duration time (F755) has elapsed the signal is true, refer to F754 and F755.
21	DO1 Output controlled by PC/PLC	1 means output is True 0 means output is False.
22	Reserved	
23	TA\TC Output controlled by PC/PLC	
24	Watchdog	The output is valid when inverter trips into Err6.
25-39	Reserved	
40	Switchover of high-frequency performance	When this function is valid, inverter will switch into high-frequency optimizing mode.

Function Parameters 9-19

F303 DO1 output types selection	Setting range: 0: level output 1 : pulse output	Mfr's value: 0
---------------------------------	---	----------------

When level output is selected, all terminal functions in table 9-2 can be defined by F301.

When pulse output is selected, DO1 can be defined as high-speed pulse output terminal. The max pulse frequency is 50KHz. The related function codes are F449、F450、F451、F452、F453.

F307 Target frequency 1	Setting range: F112~F111Hz	Mfr's value: 10.00Hz
F308 Target frequency 2		Mfr's value: 50.00Hz
F309 Frequency width	Setting range: 0~100%	Mfr's value: 50

When F300, F301, or F302 = 2 or 3 and characteristic frequency (F307) is selected, this group function codes set characteristic frequency and its width.

For example:

F301 (DO1 assignment) =2,
F307 (Target Frequency 1) =10,
F309 (Target frequency width) =10,

When frequency is higher than F307,
DO1 becomes true until the frequency is
lower than $(10-10*10\%) = 9\text{Hz}$, then
DO1 becomes false.

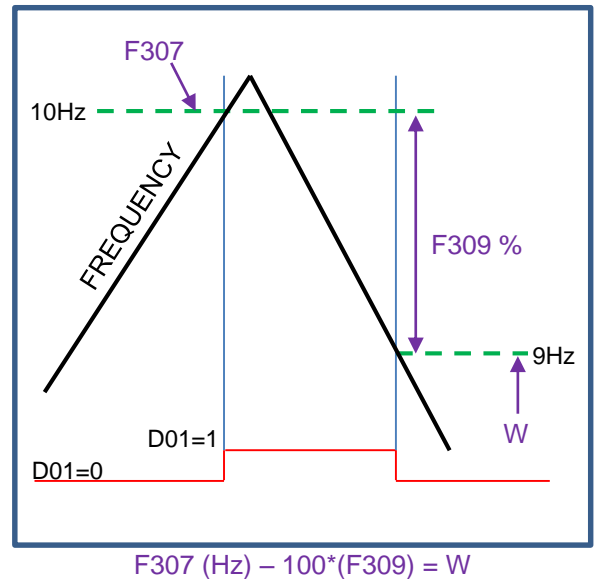

F310 Target current	Setting range: 0~5000	Mfr's value: Rated current
F311 Target current width	Setting range: 0~100	Mfr's value: 10

When F300 or F301=17 (Over latent current) is selected, this group function codes set characteristic current and its width.

For example:

F301 (DO1 assignment) =17,
F310 (Target Current) =100,
F311 (Current width) =10,

When inverter current is higher than F310,
DO1 becomes true until inverter current is
lower than $(100-100*10\%) = 90\text{A}$, then
DO1 becomes false.

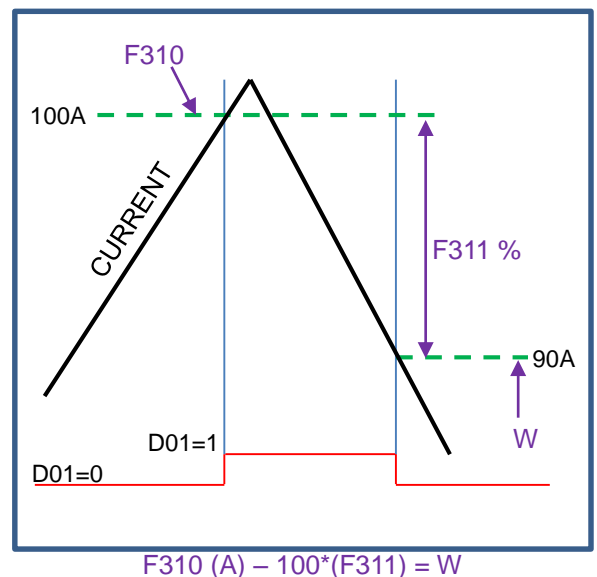

9-20 Function Parameters

F312 At Speed threshold	Setting range: 0.00~5.00Hz	Mfr's value: 0.00
-------------------------	----------------------------	-------------------

When F300=15 or F301=15, threshold range is set by F312.

For example: when F301=15, target frequency is 20HZ and F312=2, the running frequency reaches 18Hz (20-2), ON signal is output by DO1 until the running frequency reaches target frequency.

9.3.2 Digital multifunctional input terminals

F316 DI1 terminal function setting	Setting range: 0: no function 1: Run 2: Stop	Mfr's value: 11
F317 DI2 terminal function setting	3: Multi-stage speed terminal 1 4: Multi-stage speed terminal 2 5: Multi-stage speed terminal 3 6: Multi-stage speed terminal 4	Mfr's value: 9
F318 DI3 terminal function setting	7: Reset 8: Free stop 9: External coast stop	Mfr's value: 15
F319 DI4 terminal function setting	10: Acceleration/deceleration forbidden 11: Forward run jogging 12: Reverse run jogging 13: UP frequency increasing terminal 14: DOWN frequency decreasing terminal	Mfr's value: 16
F320 DI5 terminal function setting	15: "FWD" terminal 16: "REV" terminal 17: Three-line type input "X" terminal	Mfr's value: 7
F321 DI6 terminal function setting	18: Acceleration/deceleration 1 19: Reserved 20: Speed/torque switchover 21: Frequency source switchover	Mfr's value: 8
F322 DI7 terminal function setting	32: Fire control switchover 33: Emergency fire control 34: Accel / decel switchover 2 37: Common-open PTC heat protection	Mfr's value: 0
F323 DI8 terminal function setting	38: Common-close PTC heat protection 48: High-frequency switchover 52: Jogging (no direction) 53: Watchdog 54: Frequency reset 55: switchover between manual running and auto running 56: Manual running 57: Auto running 58: Direction	Mfr's value: 0

This parameter is used for setting the corresponding function for multifunctional digital input terminal.

Both free stop and external coast stop of the terminal have the highest priority.

Table 9-3 Instructions for digital multifunctional input terminal

Value	Function	Instructions
0	No function	Even if signal is input, inverter will not work. This function can be set by undefined terminal to prevent mistake action.
1	Run	When running command is given by terminal or terminals combination and this terminal is valid, inverter will run. This terminal has the same function with "I" key in keypad.
2	Stop	When stop command is given by terminal or terminals combination and this terminal is valid, inverter will stop. This terminal has the same function with "stop" key in keypad.
3	Multistage speed terminal 1	15-stage speed setpoint is selected by combination of this group of terminals. See Table 9-5.
4	Multistage speed terminal 2	
5	Multistage speed terminal 3	
6	Multistage speed terminal 4	
7	Reset	This terminal has the same function with "O" key in keypad.
8	Free stop (Coast Stop)	Inverter closes off output and motor stop process is not controlled by inverter. This mode is often used when load has big inertia or there are no requirements for stop time. This mode has the same function as F209 = 1.
9	External Trip	When this input is true an external malfunction signal is given to inverter, the keypad will display "ESP", and the inverter will stop.
10	Acceleration/deceleration Hold	When this input is true, the Inverter will not be controlled by external commands (except for stop command), and it will maintain the current output frequency.
11	Forward run jogging	Forward jogging running and reverse jogging running. Refer to F124, F125 and F126 for jogging running frequency, jogging acceleration/ deceleration time.
12	Reverse run jogging	
13	Increase frequency (UP)	When the digital frequency source is set by digital reference, the setpoint is increased by the "UP" terminal and decreased by the "DOWN" terminal. The rate is set by F211.
14	Decrease frequency (DOWN)	
15	"FWD" terminal	When start/stop command is given by terminal or terminals combination, running direction of inverter is controlled by the "FWD" and "REV" terminals.
16	"REV" terminal	
17	Three-line input "X" terminal	"FWD", "REV", "CM" terminals realize three-line control. See F208 for details.
18	Acceleration/deceleration time switchover 1	If this function is valid, the second acceleration/deceleration time will be valid. Please refer to F116 and F117.
20	Speed / torque switchover	When this input is true, the inverter switched between speed and torque control.
21	Frequency source switchover terminal	When this input is true, and F207=2, the main frequency source is replaced with the secondary frequency source.

9-22 Function Parameters

Value	Function	Instructions
		When this input is true, and F207=3, the main frequency source is switched with the sum of the main and the secondary frequency sources.
32	Fire pressure switchover	When PID control is valid and this terminal is valid, the setting value of PID switches into fire pressure given (FA58).
33	Emergency fire control	When emergency fire mode (FA59) is valid, inverter will be in emergency fire mode.
34	Acceleration / deceleration switchover 2	Please refer to Table 9-4.
37	Normally-open PTC heat protection	A normally-open contact is connected to monitor motor temperature. When this input is true, and the inverter is in the running status, the inverter will trip into OH1.
38	Normally-closed PTC heat protection	A normally-closed contact is connected to monitor motor temperature. When this input is false, and the inverter is in the running status, the inverter will trip into OH1.
48	High-frequency switchover	When this function is valid, inverter will switch into high-frequency optimizing mode.
52	Jogging (no direction)	In the application 1 and 2, the direction of jogging command is controlled by terminal set to 58: direction.
53	Watchdog	During the time set by F326 elapses without an impulse being registered, inverter will trip into Err6, and inverter will stop according to stop mode set by F327.
54	Frequency reset	In the application 4, if the function is valid, target frequency will change to the value set by F113.
55	Switchover between manual run and auto run	In application 2, when this input is true, the inverter can be switched between manual and auto run using terminals set to 55 and 56.
56	Manual run	In the application 2, if the function is valid, inverter will run manually.
57	Auto running	In the application 2, if the function is valid, inverter will run automatically.
58	Direction	Run / Jog direction. When this input is true, the inverter will run/jog reverse. When this input is false, the inverter will run/jog forward.

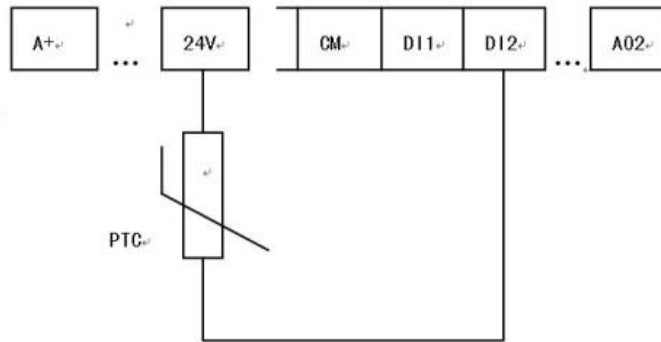

Figure 9-6 PTC Heat Protection

When the coding switch is in the end of “NPN”, PTC resistor should be connected between CM and Dlx terminal. When the coding switch is in the end of “PNP”, PTC resistor should be connected between Dlx and 24V. The recommended resistor value is 16.5KΩ.

Because the accuracy of external PTC has some differences with manufacture variation some errors can exist, thermistor protection relay is recommended.

NOTE: To use this function double insulate motor thermistor must be used.

Table 9-4 Accel/decel selection

Accel/decel switchover 2 (34)	Accel/decel switchover 1 (18)	Present accel/decel time	Related parameters
0	0	The first accel/decel time	F114, F115
0	1	The second accel/decel time	F116, F117
1	0	The third accel/decel time	F277, F278
1	1	The fourth accel/decel time	F279, F280

Table 9-5 Instructions for multistage speed

K4	K3	K2	K1	Frequency setting	Parameters
0	0	0	0	Multi-stage speed 1	F504/F519/F534/F549/F557/F565
0	0	0	1	Multi-stage speed 2	F505/F520/F535/F550/F558/F566
0	0	1	0	Multi-stage speed 3	F506/F521/F536/F551/F559/F567
0	0	1	1	Multi-stage speed 4	F507/F522/F537/F552/F560/F568
0	1	0	0	Multi-stage speed 5	F508/F523/F538/F553/F561/F569
0	1	0	1	Multi-stage speed 6	F509/F524/F539/F554/F562/F570
0	1	1	0	Multi-stage speed 7	F510/F525/F540/F555/F563/F571
0	1	1	1	Multi-stage speed 8	F511/F526/F541/F556/F564/F572
1	0	0	0	Multi-stage speed 9	F512/F527/F542/F573
1	0	0	1	Multi-stage speed 10	F513/F528/F543/F574
1	0	1	0	Multi-stage speed 11	F514/F529/F544/F575
1	0	1	1	Multi-stage speed 12	F515/F530/F545/F576
1	1	0	0	Multi-stage speed 13	F516/F531/F546/F577
1	1	0	1	Multi-stage speed 14	F517/F532/F547/F578
1	1	1	0	Multi-stage speed 15	F518/F533/F548/F579

9-24 Function Parameters

K4	K3	K2	K1	Frequency setting	Parameters
1	1	1	1	None	None

Note: 1. K4 is multi-stage speed terminal 4, K3 is multi-stage speed terminal 3, K2 is multi-stage speed terminal 2, K1 is multi-stage speed terminal 1. And 0 stands for OFF, 1 stands for ON.

0=False, 1=True

F324 Free stop terminal logic	Setting range: 0: positive logic (valid for low level); 1: negative logic (valid for high level)	Mfr's value: 0
F325 External coast stop terminal logic		Mfr's value: 0
F326 Watchdog time	Setting range: 0.0~3000.0	Mfr's value: 10.0
F327 Stop mode	Setting range: 0: Free to stop 1: Deceleration to stop	Mfr's value : 0
F328 Terminal filtering times	Setting range: 1~100	Mfr's value: 10

When multifunctional input terminal is set to free stop (coast stop) terminal (8) or external coast stop terminal (9), terminal logic level is set by this group of function codes. When F324=0 and F325=0, positive logic is selected and low level (0V) is true, when F324=1 and F325=1, negative logic is selected and high level (+24V) is true.

When F326=0.0, watchdog function is disabled.

When F327=0, If the watchdog input (53) does not pulse true, within the time period set by F326, the inverter will coast to a stop and trip on Err6.

When F327=1, If the time set by F326 elapses without an impulse being registered at the watchdog input (53), the inverter will decelerate to a stop, then inverter will trip into Err6.

F330 Diagnostics of DIX terminal	Only read
----------------------------------	-----------

F330 is used to display the diagnostics of DIX terminals.

Please refer to Figure 9-7 about the DIX terminals diagnostics in the first digit.

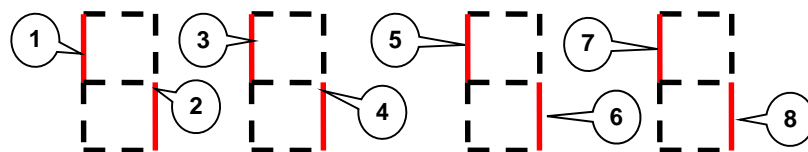

Figure 9-7 Status of digital input terminal

① stands for DI1 valid.

⑤ stands for DI5 valid.

② stands for DI2 valid.

⑥ stands for DI6 valid.

③ stands for DI3 valid.

⑦ stands for DI7 valid.

④ stands for DI4 valid.

⑧ stands for DI8 valid.

9.3.3 Analog input monitoring

F331 Monitoring AI1		Only read
F332 Monitoring AI2		Only read

The value of analog is displayed by 0~4095.

F335	Relay output simulation	Setting range: 0: Output true 1: Output false	Mfr's value: 0
F336	DO1 output simulation		Mfr's value: 0
F337	DO2 output simulation		Mfr's value: 0

As an example of DO1 output simulation, when inverter is in the stop status and enter F336, press the UP key, the DO1 terminal is valid. Release the UP key, DO1 remains valid status. After quitting F336, DO1 will revert to initial output status.

F338	AO1 output simulation	Setting range: 0~4095	Mfr's value: 0
F339	AO2 output simulation		

When inverter is in the stop status, and enter F338, press the UP key, the output analog will increase, and when press the DOWN key, the output analog will decrease. After quitting the parameters, AO1 will revert to initial output status.

F340 Selection of terminal negative logic	Setting range: 0: None 1: DI1 negative logic 2: DI2 negative logic 4: DI3 negative logic 8: DI4 negative logic 16: DI5 negative logic 32: DI6 negative logic 64: DI6 negative logic 128: DI8 negative logic	Mfr's value: 0
---	--	----------------

For example if user wants to set DI1 and DI4 to negative logic, set F340=1+8=9

9.4 Analog Input and Output

AC10 series inverters have 2 analog input channels and 2 analog output channels.

F400	Lower limit of AI1 channel input (V)	Setting range: 0.00~F402	Mfr's value: 0.04
F401	Corresponding setting for lower limit of AI1 input	Setting range: 0~F403	Mfr's value: 1.00
F402	Upper limit of AI1 channel input (V)	Setting range: F400~10.00	Mfr's value: 10.00
F403	Corresponding setting for upper limit of AI1 input	Setting range: Max (1.00, F401) ~2.00	Mfr's value: 2.00
F404	AI1 channel proportional gain K1	Setting range: 0.0~10.0	Mfr's value: 1.0
F405	AI1 filtering time constant (s)	Setting range: 0.1~10.0	Mfr's value: 0.10

When using analog inputs for speed control, sometimes it is necessary to scale the relationship between the upper limit and lower limit of the value input analog, analog changes and the output frequency, to achieve a satisfactory speed control effect.

The upper and lower limit of analog input are set by F400 and F402.

9-26 Function Parameters

For example: when F400=1, F402=8, if analog input voltage is lower than 1V, system judges it as 0. If input voltage is higher than 8V, system judges it as 10V (suppose analog channel selects 0-10V). If Max frequency F111 is set to 50Hz, the output frequency corresponding to 1-8V is 0-50Hz.

The filtering time constant is set by F405.

The greater the filtering time constant is, the more stable for the analog testing. However, the precision may decrease to a certain extent. It may require appropriate adjustment according to actual application.

Channel proportional gain is set by F404.

If 1V corresponds to 10Hz and F404=2, then 1V will correspond to 20Hz.

Corresponding setting for upper / lower limit of analog input are set by F401 and F403.

If Max frequency F111 is 50Hz, analog input voltage 0-10V can correspond to output frequency from -50Hz to 50Hz by setting these group function codes. Please set F401=0 and F403=2, then 0V corresponds to -50Hz, 5V corresponds to 0Hz and 10V corresponds to 50Hz. The unit scaling the upper / lower limit of input is in percentage (%). If the value is greater than 1.00, it is positive; if the value is less than 1.00, it is negative. (e.g. F401=0.5 represents -50%).

If the running direction is set to forward running by F202, then 0-5V corresponding to the minus frequency will cause reverse running, or vice versa.

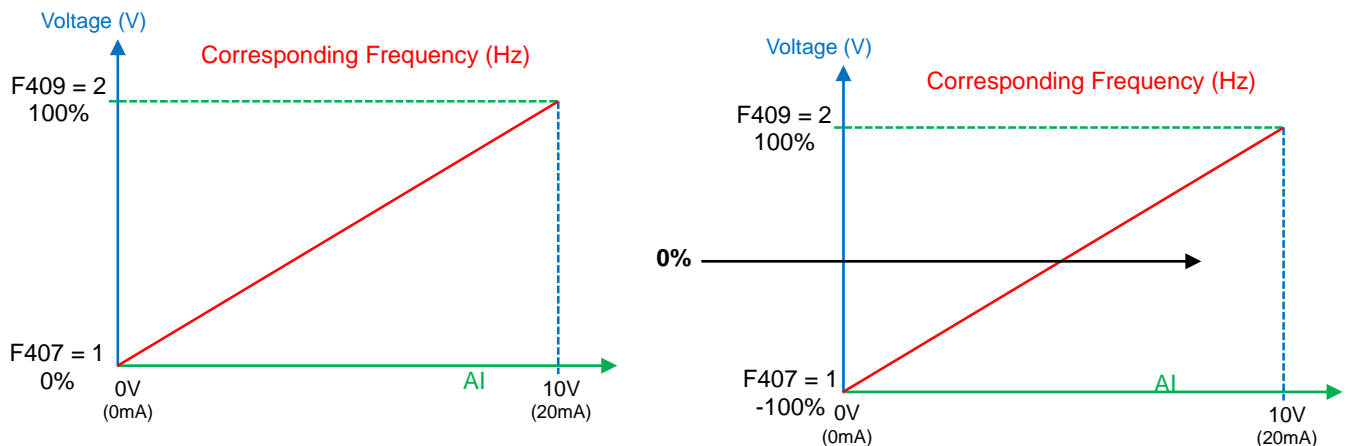
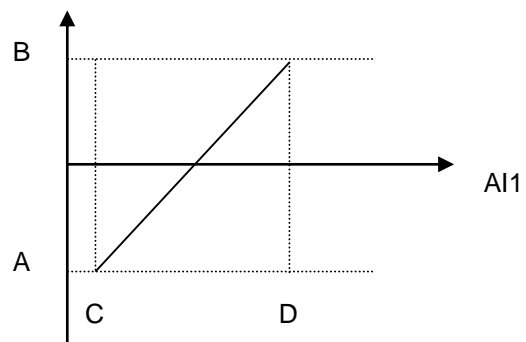

Figure 9-8 Correspondence of analog input to setting

The unit of for scaling the upper / lower limit of input is in percentage (%). If the value is greater than 1.00, it is positive; if the value is less than 1.00, it is negative. (e.g. F401=0.5 represents -50%).

The corresponding setting benchmark: in the mode of combined speed control, analog is the secondary frequency and the setting benchmark for range of secondary frequency which relates to main frequency is "main frequency X"; corresponding setting benchmark for other cases is the "max frequency", as illustrated in the above figure.



	AI1	AI2	
A	(F401-1)	(F407-1)	Should be max frequency (F111)
B	(F403-1)	(F409-1)	Should be max frequency (F111)
C	F400	F406	Low limit of Aix channel input (V)
D	F402	F408	Upper limit of Aix channel input (V)

Function Parameters 9-27

F406	Lower limit of AI2 channel input (V)	Setting range: 0.00~F408	Mfr's value: 0.01
F407	Corresponding setting for lower limit of AI2 input	Setting range: 0~F409	Mfr's value: 1.00
F408	Upper limit of AI2 channel input (V)	Setting range: F406~10.00	Mfr's value: 10.00
F409	Corresponding setting for upper limit of AI2 input	Setting range: Max (1.00, F407) ~2.00	Mfr's value: 2.00
F410	AI2 channel proportional gain K2	Setting range: 0.0~10.0	Mfr's value: 1.0
F411	AI2 filtering time constant (s)	Setting range: 0.1~50.0	Mfr's value: 0.1

The function of AI2 is the same with AI1.

F418	AI1 channel 0Hz voltage dead zone	Setting range: 0~0.50V (Positive-Negative)	Mfr's value: 0.00
F419	AI2 channel 0Hz voltage dead zone	Setting range: 0~0.50V (Positive-Negative)	Mfr's value: 0.00

An analog input voltage 0-5V can correspond to output frequency -50Hz-50Hz (2.5V corresponds to 0Hz) by setting the function of corresponding setting for upper / lower limit of analog input. The function codes F418 and F419 set the voltage range corresponding to 0Hz.

For example, if F418=0.5 and F419=0.5, then the voltage range from $(2.5-0.5 = 2)$ to $(2.5+0.5 = 3)$ corresponds to 0Hz. If the voltage is in the range of 2 to 3 volts, the inverter will output 0Hz.

0HZ voltage dead zone will be valid when corresponding setting for lower limit of input is less than 1.00.

F421 Keypad selection	Setting range: 0: Local keypad panel 1: Remote control keypad panel 2: local keypad + remote keypad	Mfr's value: 1
-----------------------	--	----------------

When F421 is set to 0, local keypad panel is working. When F421 is set to 1, remote control keypad panel is working, and local keypad panel will be disabled for saving energy.

The remote control panel is connected by 8-conductor network cable (RJ45).

AC10 has one analog output channel (AO1) selectable for current or voltage output.

F423 AO1 output range	Setting range: 0: 0~5V; 1: 0~10V or 0~20mA 2: 4~20mA	Mfr's value: 1
F424 AO1 lowest corresponding frequency (Hz)	Setting range: 0.0~F425	Mfr's value: 0.05
F425 AO1 highest corresponding frequency (Hz)	Setting range: F424~F111	Mfr's value: 50.00
F426 AO1 output compensation (%)	Setting range: 0~120	Mfr's value: 100

AO1 output range is selected by F423. When F423=0, AO1 output range selects 0-5V, and when F423=1, AO1 output range selects 0-10V or 0-20mA. When F423=2, AO1 output range selects 4-20mA (When AO1 output range selects current signal, please turn the switch J5 to "I" position).

Correspondence of output voltage range (0-5V or 0-10V) to output frequency is set by F424 and F425. For example, when F423=0, F424=10 and F425=120, analog channel AO1 outputs

9-28 Function Parameters

0-5V and the output frequency is 10-120Hz.

AO1 output compensation is set by F426. Analog excursion can be compensated by setting F426.

F427 AO2 output range	Setting range: 0: 0~20mA; 1: 4~20 mA	Mfr's value: 0
F428 AO2 lowest corresponding frequency (Hz)	Setting range: 0.0~F429	Mfr's value: 0.05
F429 AO2 highest corresponding frequency (Hz)	Setting range: F428~F111	Mfr's value: 50.00
F430 AO2 output compensation (%)	Setting range: 0~120	Mfr's value: 100

The function of AO2 is the same as AO1, but AO2 will output current signal, current signal of 0-20mA and 4-20mA could be selected by F427.

F431 AO1 analog output signal	Setting range: 0: Running frequency; 1: Output current; 2: Output voltage; 3: Analog AI1; 4: Analog AI2; 6: Output torque; 7: Given by PC/PLC; 8: Target frequency	Mfr's value: 0
F432 AO2 analog output signal		Mfr's value: 1

When output current is selected, analog output signal is from 0 to twice rated current.

When output voltage is selected, analog output signal is from 0V to rated output voltage.

F433 Corresponding current for full range of external voltmeter	Setting range: 0.01~5.00 times of rated current	Mfr's value: 2.00
F434 Corresponding current for full range of external ammeter		Mfr's value: 2.00

In case of F431=1 and AO1 channel for token current, F433 is the ratio of measurement range of external voltage type ammeter to rated current of the inverter.

In case of F432=1 and AO2 channel for token current, F434 is the ratio of measurement range of external current type ammeter to rated current of the inverter.

For example: measurement range of external ammeter is 20A, and rated current of the inverter is 8A, then, $F433=20/8=2.50$.

F437 Analog filter width	Setting range: 1~100	Mfr's value:10
--------------------------	----------------------	----------------

The greater the value of F437, the more stable the analog monitoring will be, but the slower the response speed will be. Adjust the filter according to the actual system requirements.

F460 AI1 channel input mode	Setting range: 0: straight line mode 1: folding line mode	Mfr's value: 0
F461 AI2 channel input mode	Setting range: 0: straight line mode 1: folding line mode	Mfr's value: 0
F462 AI1 insertion point A1 voltage value (V)	Setting range: F400~F464	Mfr's value: 2.00
F463 AI1 insertion point A1 setting value	Setting range: F401~F465	Mfr's value: 1.20
F464 AI1 insertion point A2 voltage value (V)	Setting range: F462~F466	Mfr's value: 5.00
F465 AI1 insertion point A2 setting value	Setting range: F463~F467	Mfr's value: 1.50
F466 AI1 insertion point A3 voltage value (V)	Setting range: F464~F402	Mfr's value: 8.00
F467 AI1 insertion point A3 setting value	Setting range: F465~F403	Mfr's value: 1.80
F468 AI2 insertion point B1 voltage value (V)	Setting range: F406~F470	Mfr's value: 2.00
F469 AI2 insertion point B1 setting value	Setting range: F407~F471	Mfr's value: 1.20
F470 AI2 insertion point B2 voltage value (V)	Setting range: F468~F472	Mfr's value: 5.00
F471 AI2 insertion point B2 setting value	Setting range: F469~F473	Mfr's value: 1.50
F472 AI2 insertion point B3 voltage value (V)	Setting range: F470~F412	Mfr's value: 8.00
F473 AI2 insertion point B3 setting value	Setting range: F471~F413	Mfr's value: 1.80

When analog channel input mode selects straight-line, please set it according to the parameters from F400 to F429. When folding line mode is selected, three points A1(B1, A2(B2), A3(B3) are inserted into the straight line, each of which can set the according frequency to input voltage. Please refer to Figure 9-9:

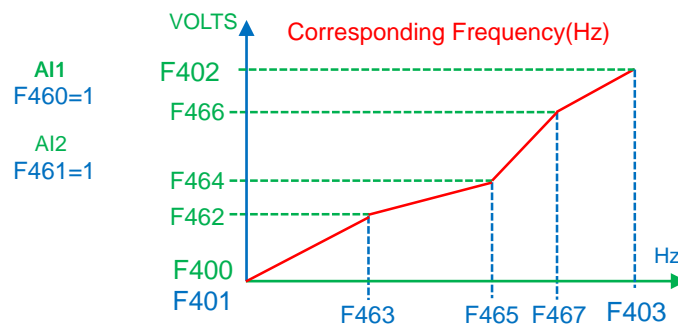

Figure 9-9 Folding analog with setting value

F400 and F402 are lower/upper limit of analog AI1 input. When F460=1, F462=2.00V, F463=1.4, F111=50, F203=1, F207=0, then A1 point corresponding frequency is $(F463-1) * F111=20\text{Hz}$, which means 2.00V corresponding to 20Hz. The other points can be set by the same way.

AI2 channel has the same setting way as AI1.

9.5 Multi-stage Speed Control

The function of multi-stage speed control is equivalent to a built-in PLC in the inverter. This function can set running time, running direction and running frequency.

AC10 series inverter can achieve 15-stage speed control and 8-stage speed auto circulating.

During the process of Flycatching, multi-stage speed control is invalid. After Flycatching is finished, inverter will run to target frequency according to the setting value of parameters.

9-30 Function Parameters

F500 Stage speed type	Setting range: 0: 3-stage speed; 1: 15-stage speed; 2: Max 8-stage speed auto circulating	Mfr's value: 1
-----------------------	--	----------------

In case of multi-stage speed control (F203=4), the user must select a mode by F500. When F500=0, 3-stage speed is selected. When F500=1, 15-stage speed is selected. When F500=2, max 8-stage speed auto circulating is selected. When F500=2, "auto circulating" is classified into "2-stage speed auto circulating", "3-stage speed auto circulating", ... "8-stage speed auto circulating", which is to be set by F501.

Table 9-6 Selection of Stage Speed Running Mode

F203	F500	Mode of Running	Description
4	0	3-stage speed control	The priority in turn is stage-1 speed, stage-2 speed and stage-3 speed. 3-stage speed control can be combined with analog speed control. If F207=4, "3-stage speed control" is prior to analog speed control.
4	1	15-stage speed control	15-stage speed control can be combined with analog speed control. If F207=4, "15-stage speed control" is prior to analog speed control.
4	2	Max 8-stage speed auto circulating	Adjusting the running frequency manually is not allowed. The number of speed control stages may be selected via F501.

F501 Selection of Stage Speed Under Auto-circulation Speed Control	Setting range: 2~8	Mfr's value: 7
F502 Selection of number of cycles of Auto-circulation Speed Control	Setting range: 0~9999 (when the value is set to 0, the inverter will carry out infinite circulating)	Mfr's value: 0
F503 Status After Auto-circulation Running Finished.	Setting range: 0: Stop 1: Keep running at last-stage speed	Mfr's value: 0

If running mode is auto-circulation speed control (F203=4 and F500=2), please set the related parameters by F501~F503 define the auto-circulation cycle characteristics.

The inverter runs at the preset stage speed one by one under the auto-circulation speed control is called as cycle.

If F502=0, inverter will run at infinite auto circulation, which will be stopped by "stop" signal.

If F502>0, inverter will run at auto circulation conditionally. When auto circulation of the preset cycles is finished continuously (set by F502), inverter will finish auto-circulation running conditionally. When inverter keeps running and the preset cycles is not finished, if inverter receives "stop command", inverter will stop. If inverter receives "run command" again, inverter will automatically circulate by the setting time of F502.

If F503=0, then inverter will stop after auto circulation is finished. If F503=1, then inverter will run at the speed of the last-stage after auto-circulation is finished as follows:

- F501=3, the inverter will run 3-stage speed auto circulation
- F502=100, the inverter will run 100 cycles of auto circulation
- F503=1, the inverter will continue to run at the speed of the last stage after the number of auto-circulation cycles is completed

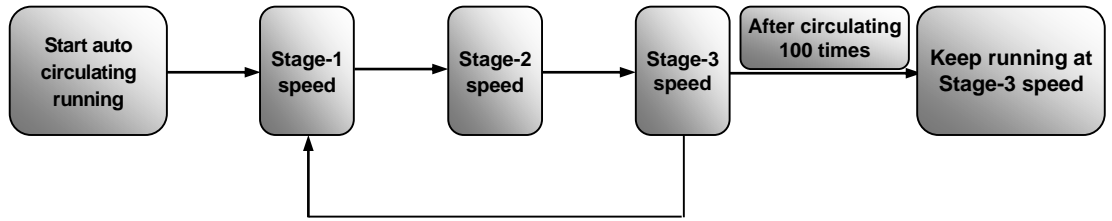

Figure 9-10 Auto-circulating Running

The inverter can be stopped by pressing “O” or sending “O” signal through terminal during auto-circulation running.

F504	Frequency setting for stage 1 speed (Hz)	Setting range: F112~F111	Mfr's value: 5.00	
F505	Frequency setting for stage 2 speed (Hz)		Mfr's value: 10.00	
F506	Frequency setting for stage 3 speed (Hz)		Mfr's value: 15.00	
F507	Frequency setting for stage 4 speed (Hz)		Mfr's value: 20.00	
F508	Frequency setting for stage 5 speed (Hz)		Mfr's value: 25.00	
F509	Frequency setting for stage 6 speed (Hz)		Mfr's value: 30.00	
F510	Frequency setting for stage 7 speed (Hz)		Mfr's value: 35.00	
F511	Frequency setting for stage 8 speed (Hz)		Mfr's value: 40.00	
F512	Frequency setting for stage 9 speed (Hz)		Mfr's value: 5.00	
F513	Frequency setting for stage 10 speed (Hz)		Mfr's value: 10.00	
F514	Frequency setting for stage 11 speed (Hz)		Mfr's value: 15.00	
F515	Frequency setting for stage 12 speed (Hz)		Mfr's value: 20.00	
F516	Frequency setting for stage 13 speed (Hz)		Mfr's value: 25.00	
F517	Frequency setting for stage 14 speed (Hz)		Mfr's value: 30.00	
F518	Frequency setting for stage 15 speed (Hz)		Mfr's value: 35.00	
F519~F533	Acceleration time setting for the speeds from Stage 1 to Stage 15 (s)		Setting range: 0.1~3000	Subject to inverter model
F534~F548	Deceleration time setting for the speeds from Stage 1 to Stage 15 (s)		Setting range: 0.1~3000	
F549~F556	Running directions of stage speeds from Stage 1 to Stage 8		Setting range: 0: forward running; 1: reverse running	Mfr's value: 0
F557~564	Running time of stage speeds from Stage 1 to Stage 8 (s)	Setting range: 0.1~3000	Mfr's value: 1.0	
F565~F572	Stop time after finishing stages from Stage 1 to Stage 8 (s)	Setting range: 0.0~3000	Mfr's value: 0.0	
F573~F579	Running directions of stage speeds from stage 9 to stage 15	Setting range: 0: forward running; 1: reverse running	Mfr's value: 0	

9-32 Function Parameters

9.6 Auxiliary Functions

F600 DC Braking Function Selection	Setting range: 0: Disabled 1: Braking before starting 2: Braking during stopping 3: Braking during starting and stopping	Mfr's value: 0
F601 Initial Frequency for DC Braking (Hz)	Setting range: 0.20~5.00	Mfr's value: 1.00
F602 DC Braking efficiency before Starting	Setting range: 0~100	Mfr's value: 10
F603 DC Braking efficiency During Stop		
F604 Duration of Braking Before Starting (s)	Setting range: 0.0~10.0	Mfr's value: 0.5
F605 Duration of Braking During Stopping (s)		

When F600=0, DC braking function is disabled.

When F600=1, braking before starting is valid. After the right starting signal is input, inverter starts DC braking. After braking is finished, inverter will run from the initial frequency.

In some applications, such as fan, motor is running at a low speed or in a reverse status, if inverter starts immediately, OC malfunction will occur. Adopting "braking before starting" will ensure that the fan stays in a static state before starting to avoid this malfunction.

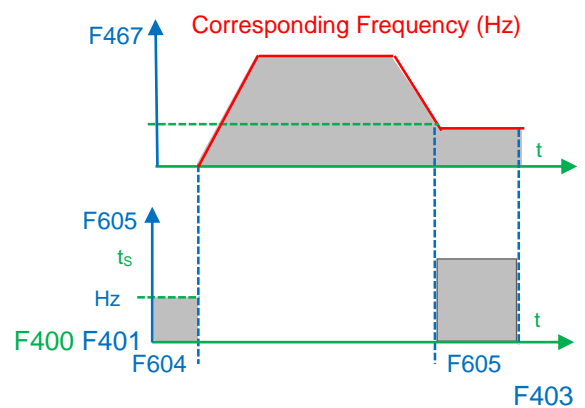

Figure 9-11 DC Braking

During braking before starting, if "stop" signal is given, inverter will stop by deceleration time.

When F600=2, DC braking during stopping is selected. After output frequency is lower than the initial frequency for DC braking (F601), DC braking will stop the motor immediately

During the process of braking during stopping, if "start" signal is given, DC braking will be finished and inverter will start.

If "stop" signal is given during the process of braking during stopping, inverter will have no response and DC braking during stopping still goes on.

Parameters related to "DC Braking":

- F601: Initial frequency of DC-braking. DC braking will start to work as inverter's output frequency is lower than this value.
- F604: Braking duration before starting. The length of time for DC braking before inverter starts
- F605: Braking duration when stopping. The length of time for DC braking while inverter stops.

Note: Excessive DC braking can damage an AC motor. At low speeds a motor without forced air cooling (like a TEBC motor would) does not have sufficient self-cooling, and may be easily over-heated. Do not set DC braking voltage (F602, F603) too high or set DC braking time (F604, F605) too long. DC braking is not recommended in an application where there will be more than 4 stops per hour.

DC braking, as shown in Figure 9-11.

F607 Selection of Stalling Adjusting Function	Setting range: 0: Disabled; 1: Enabled 2: Reserved 3: Voltage current control 4: Voltage control 5: Current control	Mfr's value: 0
F608 Stalling Current Adjusting (%)	Setting range: 60~200	Mfr's value: 160
F609 Stalling Voltage Adjusting (%)	Setting range: 110~200	Mfr's value: 1 phase: 130 3 phase: 140
F610 Stalling Protection Judging Time (s)	Setting range: 0.1~3000.0	Mfr's value: 60.0

F607 is used to set selection of stalling adjusting function.

Voltage control: when motor stops quickly or load changes suddenly, DC bus voltage will be high. Voltage control function can adjust deceleration time and output frequency to avoid OE trips.

When braking resistor or braking unit is used, do not use voltage control function otherwise, the deceleration time will be changed.

Current control: when motor accelerates quickly or load changed suddenly, inverter may trip into OC. Current control function can adjust accel/decel time or decrease output frequency to control proper current value. It is only valid in VF control mode.

Note: (1) Voltage/current control is not suitable for lifting application.

(2) This function will change accel/decel time. Please use this function properly.

Initial value of stalling current adjusting is set by F608, when the present current is higher than rated inverter current *F608, stalling current adjusting function is valid.

During the process of deceleration, stalling current function is invalid.

During the process of acceleration, if output current is higher than initial value of stalling current adjusting and F607=1, then stalling adjusting function is valid. Inverter will not accelerate until the output current is lower than initial value of stalling current adjusting.

In case of stalling during stable speed running, the frequency will drop. If the current returns to normal during a stall condition the frequency will rise. Otherwise, the frequency will keep dropping to the minimum frequency and the protection OL1 will occur after it lasts for the time as set in F610.

Initial value of stalling voltage adjusting is set by F609, when the present voltage is higher than rated voltage *F609, stalling voltage adjusting function is active.

Stalling voltage adjusting is valid during the process of deceleration, including the deceleration process caused by stalling current.

Over-voltage means the DC bus voltage is too high, and it is usually caused during deceleration when the DC bus voltage will increase because of energy feedback. When DC bus voltage is higher than the value of stall voltage (F609) and F607=1, then stall adjustment function is active. The inverter will temporarily stop decelerating and keep output frequency constant, this stops energy being fed back into the inverter. Inverter will not decelerate until DC bus voltage is lower than the value of stall voltage (F609).

Stalling protection judging time is set by F610. When inverter starts stalling adjusting function and continues the period of time set by F610, inverter will stop running and OL1 protection occurs.

F611 Dynamic Braking threshold	Setting range: 200~1000	Subject to inverter model
F612 Dynamic braking duty ratio (%)	Setting range: 0~100%	Mfr's value: 80

The starting voltage for the dynamic braking transistor is set by F611, which is in units of V.

9-34 Function Parameters

When DC bus voltage is higher than the setting value of this function, the braking unit starts working. After DC bus voltage is lower than the setting value, braking unit stops working.

Dynamic braking duty ratio is set by F612, the range is 0~100%. If the braking duty ratio is higher, the braking effect is better, but the braking resistor will get hotter

F613 Flycatching	Setting range: 0: Disabled 1: Enabled 2: Enabled the first time	Mfr's value: 0
------------------	--	----------------

When F613=0, the function of Flycatching is disabled.

When F613=1, the function of Flycatching is enabled.

After inverter detects motor speed and rotating direction, the inverter will begin ramping up to the commanded frequency, to seamlessly catch the rotating motor. This function is suitable for situations where the inverter is auto-started after repowered on, auto-started after reset, auto-started after the direction signal is lost while the inverter is running, and when the inverter is auto-started after a fault. Flycatching is useful for large inertia fan loads, where drafts can cause a fan to 'windmill'

When F613=2, Flycatching is enabled the first time the inverter is powered on or restarted.

Note: When the control mode is set to Sensorless Vector control (F106=0), Flycatching is disabled.

F614 Flycatching mode	Setting range: 0: Flycatching from frequency memory 1: Flycatching from max frequency 2: Flycatching from frequency memory and direction memory 3: Flycatching from max frequency and direction memory	Mfr's value: 0
-----------------------	--	----------------

When F614 is set to 0 or 1, if memory frequency or max frequency is lower than 10.00Hz, inverter will track speed from 10.00Hz.

If inverter is powered down, inverter will remember valid target frequency. For other situations (inverter has no output before stop), inverter will remember setpoint frequency before it stops.

Flycatching is used for restarting a motor with a high inertia. A motor with high inertia will take a long time to stop completely. By using Flycatching, the user does not need to wait for the motor to come to a complete stop before restarting the inverter.

F615 Flycatching rate	Setting range: 1~100	Mfr's value: 20
-----------------------	----------------------	-----------------

The Flycatching rate is used to select the rotation velocity Flycatching when the rotation tracking restart mode is adopted. Increasing this parameter improves the speed at which the Flycatching is accomplished. If this parameter is too large, it is likely to result in unreliable tracking.

F619 Flycatching fault timeout period	Setting range: 0.0~3000.0S	Mfr's value: 60.0s
---------------------------------------	----------------------------	--------------------

When F619=0, the function is not valid. When F619≠0, the function is valid. When Flycatching time is longer than the setting value of F619, it will trip into FL

Function Parameters 9-35

F622 Dynamic braking mode	Setting range: 0: Fixed duty ratio 1: Auto duty ratio	Mfr's value: 1
---------------------------	---	----------------

When F622=0, fixed duty ratio is valid. When bus-line voltage reaches energy consumption brake point set by F611, braking module will start dynamic braking according to F612.

When F622=1, auto duty ratio is valid. When bus-line voltage reaches dynamic braking threshold set by F611, braking module will start dynamic braking according to duty ratio which is adjusted by the bus-line voltage. The higher bus-line voltage is, the greater duty ratio is, and the better braking effect is. The braking resistor will get hotter.

F627 Current limiting when Flycatching	50-200	100
--	--------	-----

This function limits the output current when Flycatching.

F631 VDC adjustment selection	0: Disabled 1: Enabled 2: reserved	Subject to inverter model
F632 Target voltage of VDC adjustor (V)	Setting range: 200~800	

When F631=1, VDC adjustment function is valid. During motor running process, the PN bus voltage will rise suddenly because of load mutation, over-voltage protection will occur. VDC adjustment is used to control voltage steady by adjusting output frequency or reducing braking torque.

If the DC bus voltage is higher than the setting value of F632, VDC adjustor will automatically adjust the bus voltage same as the value of F632.

VDC adjustment is disabled when Control mode is PMSM Sensorless Vector control (F106=6).

F650 High-frequency performance	Setting range: 0: Invalid 1: Terminal enabled 2: Enabled mode 1 3: Enabled mode 2	Mfr's value: 2
F651 Switchover frequency 1	Setting range: F652-150.00	Mfr's value: 100.0
F652 Switchover frequency 2	Setting range: 0-F651	Mfr's value: 95.00

F650 is valid in vector control mode.

Enabled mode 1: when frequency is higher than F651, the inverter will calculate for optimized performance. When frequency is lower than F652, the calculation will be stopped.

Enabled mode 2: when frequency is higher than F651, inverter will calculate for optimized performance until inverter stops.

Terminal enabled: when function of DIX terminal is set to 48, if DIX terminal is true, the inverter will calculate for optimized performance.

Note: This function does not apply to inverters 30kW and above.

9-36 Function Parameters

9.7 Malfunction and Protection

F700 Selection of terminal free stop mode	Setting range: 0: free stop immediately; 1: delayed free stop	Mfr's value: 0
F701 Delay time for free stop and programmable terminal action	Setting range: 0.0~60.0	Mfr's value: 0.0

“Selection of free stop mode” can be used only for the mode of “free stop” controlled by the terminal. The related parameters setting is F201=1, 2, 4 and F209=1.

When “free stop immediately” is selected, delay time (F701) will be invalid and inverter will free stop immediately.

“Delayed free stop” means that upon receiving “free stop” signal, the inverter will execute “free stop” command after waiting some time instead of stopping immediately. Delay time is set by F701.

F702 Fan control mode	0: controlled by temperature 1: Running when inverter is powered on. 2: controlled by running status	Mfr's value: 2
-----------------------	--	----------------

When F702=0, fan will run if the heat sink temperature is up to setting temperature.

When F702=2, fan will run when inverter begins running. When inverter stops, fan won't stop until the heat sink temperature is lower than setting temperature.

F704 Inverter Overloading pre-alarm setpoint (%)	Setting range: 50~100	Mfr's value: 80
F705 Motor Overloading pre-alarm setpoint (%)	Setting range: 50~100	Mfr's value: 80
F706 Inverter Overloading Coefficient (%)	Setting range: 120~190	Mfr's value: 150
F707 Motor Overloading Coefficient (%)	Setting range: 20~100	Mfr's value: 100

Inverter overload pre-alarm (warning) setpoint (F704): the ratio of overload-protection current and rated current, whose value shall be subject to actual load.

Inverter overload setpoint (F706): the ratio of overload-protection current and rated current, whose value shall be subject to actual load. An inverter overload fault (OL1) will occur when actual load exceeds this value for the specified time.

Motor overload pre-alarm (warning) setpoint (F705): when inverter drives lower power motor, set the value of F707 by below formula in order to protect motor. A motor overload fault (OL2) will occur when actual load exceeds this value for the specified time

Motor overload setpoint (F707): when inverter drives lower power motor, set the value of F707 by below formula in order to protect motor:

$$\text{Motor Overloading Coefficient} = \frac{\text{Rated motor power}}{\text{Rated inverter power}} \times 100\%$$

Set F707 according to actual situation. The lower the setting value of F707 is, the faster the overload protection speed, refer to Figure 9-12.

For example: 7.5kW inverter drives 5.5kW motor, $F707=5.5/7.5 \times 100\% \approx 70\%$. When the actual current of motor reaches 140% of inverter rated current, motor overload protection will display after 1 minute.

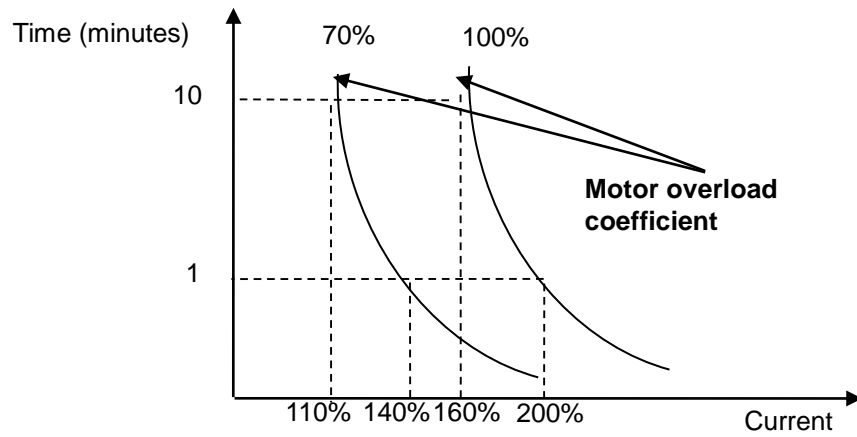

Figure 9-12 Motor overload coefficient

When the output frequency is lower than 10Hz, the heat dissipation effect of common motor will be worse. So when running frequency is lower than 10Hz, the threshold of motor overload value will be reduced. Please refer to Figure 9-13 (F707=100%):

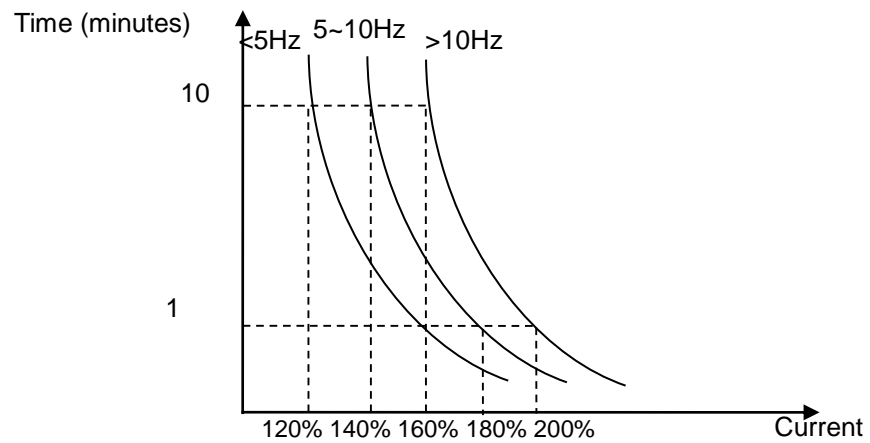

Figure 9-13 Motor overload protection value

9-38 Function Parameters

F708	Trip 1 Type (Newest)	Setting range: 2: Over current (OC) 3: Over voltage (OE) 4: Input phase loss (PF1) 5: Inverter overload (OL1) 6: Under voltage (LU) 7: Overheat (OH) 8: Motor overload (OL2) 11: External malfunction (ESP) 12: Current fault before running (Err3) 13: Tuning parameters wrong (Err2) 15: Current sampling fault (Err4) 16: Over current 1 (OC1) 17: Output phase loss (PF0) 18: Analog disconnected (Aerr) 23: PID parameters are set wrong (Err5) 45: Communication timeout (CE) 46: Flycatching fault (FL) 49: Watchdog fault (Err6) 67: Overcurrent (OC2)	
F709	Trip 2 Type		
F710	Trip 3 Type		
F711	Trip 1 Fault Frequency		
F712	Trip 1 Fault Current		
F713	Trip 1 Fault DC Bus Voltage		
F714	Trip 2 Fault Frequency		
F715	Trip 2 Fault Current		
F716	Trip 2 Fault DC Bus Voltage		
F717	Trip 3 Fault Frequency		
F718	Trip 3 Fault Current		
F719	Trip 3 Fault DC Bus Voltage		
F720	Number of overcurrent faults		
F721	Number of overvoltage faults		
F722	Number of overheat faults		
F723	Number of overload faults		
F724	Input phase loss (For single-phase input, set to true)	Setting range: 0: Disabled; 1: Enabled	Mfr's value: 1
F726	Overheat	Setting range: 0: Disabled; 1: Enabled	Mfr's value: 1
F727	Output phase loss	Setting range: 0: Disabled; 1: Enabled	Mfr's value: 0
F728	Input phase loss trip delay (S)	Setting range: 0.1~60.0	Mfr's value: 0.5
F730	Overheat protection trip delay (S)	Setting range: 0.1~60.0	Mfr's value: 5.0

F732 Under-voltage threshold (V)	Setting range: 0~450	Subject to inverter model
----------------------------------	----------------------	---------------------------

“Under-voltage” refers to too low voltage at AC input side.

“Input phase loss” refers to phase loss of three-phase power supply, 5.5 kW and below inverters have not got this function.

“Output phase loss” refers to phase loss of inverter three-phase wirings or motor wirings.

·“Phase loss” signal filtering constant is used for the purpose of eliminating disturbance to avoid mis-protection. The greater the set value is, the longer the filtering time constant is and the better for the filtering effect.

F737 Over-current 1 protection	Setting range: 0: Disabled 1: Enabled	Mfr's value: 1
F738 Over-current 1 protection coefficient	Setting range: 0.50~3.00	Mfr's value: 2.50
F739 Over-current 1 protection record		

F738= OC 1 value/inverter rated current.

In running status, F738 is not allowed to modify. When over-current occurs, OC1 is displayed

F741 Analog disconnected protection	Setting range: 0: Disabled 1: Stop and AErr displays. 2: Stop and AErr is not displayed. 3: Inverter runs at the min frequency. 4: Reserved.	Mfr's value: 0
F742 Threshold of analog disconnected protection (%)	Setting range: 1~100	Mfr's value: 50

When the values of F400 and F406 are lower than 0.01V, analog disconnected protection is invalid.

When F741 is set to 1, 2 or 3, the values of F400 and F406 should be set to 1V-2V, to avoid the error protection by interference.

Analog disconnected protection voltage=analog channel input lower limit * F742. Take the AI1 channel for the example, if F400=1.00, F742=50, then disconnection protection will occur when the AI1 channel voltage is lower than 0.5V.

F745 Threshold of pre-alarm overheat (%)	Setting range: 0~100	Mfr's value: 80
F747 Carrier frequency auto-adjusting	Setting range: 0: Disabled 1: Enabled	Mfr's value: 1

When the temperature of the heatsink reaches the value of 95°C X F745 and multi-function output terminal is set to 16 (refer to F300~F302), it indicates inverter is in the status of overheat, and when F747=1, the temperature of the heatsink reaches 86°C, inverter carrier frequency will adjust automatically, to decrease the temperature of inverter. This function can avoid overheat malfunction.

When F159=1, random carrier frequency is selected, F747 is disabled.

When F106=6, carrier frequency auto adjusting function is disabled.

9-40 Function Parameters

F754 Zero-current threshold (%)	Setting range: 0~200	Mfr's value: 5
F755 Duration time of zero-current (s)	Setting range: 0~60	Mfr's value: 0.5

When the output current has fallen to zero-current threshold, and after the duration time of zero-current, ON signal is output.

9.8 Motor Parameters

F800 Motor's parameters tuning	Setting range: 0: Disabled; 1: Rotating tuning; 2: Stationary tuning	Mfr's value: 0
F801 Rated power (kW)	Setting range: 0.75~1000	
F802 Rated voltage (V)	Setting range: 1~440	
F803 Rated current (A)	Setting range: 0.1~6500	
F804 Number of motor poles	Setting range: 2~100	4
F805 Rated rotary speed (rpm/min)	Setting range: 1~30000	
F810 Motor rated frequency (Hz)	Setting range: 1.0~590.0	50.00

Set the parameters in accordance with those indicated on the nameplate of the motor.

Good control performance of vector control requires accurate parameters of the motor. (Accurate parameter tuning requires correct setting of rated parameters of the motor.)

In order to get excellent control performance, configure the motor in accordance with adaptable motor of the inverter. In the case of too large difference between the actual power of the motor and that of adaptable motor for inverter, the inverter's control performance will decrease remarkably.

F800=0, parameter tuning is invalid. But it is still necessary to set the parameters F801~F803, F805 and F810 correctly according to those indicated on the nameplate of the motor.

After being powered on, it will use default parameters of the motor (see the values of F806-F809) according to the motor power set in F801. This value is only a reference value in view of Y series 4-pole asynchronous motor.

F800=1, rotating tuning.

In order to ensure dynamic control performance of the inverter, select "rotating tuning" after ensuring that the motor is disconnected from the load. Set F801-805 and F810 correctly prior to running the rotating autotune.

Press the "I" key on the keypad to display "TEST", and the inverter will tune the motor's parameter in two stages. After that, the motor will accelerate according to acceleration time set at F114 and maintain it for a certain period. The motor will then decelerate to 0 according to the time set at F115. After auto-checking is completed, relevant parameters of the motor will be stored in function codes F806~F809, and F800 will be automatically set back to 0.

F800=2, stationary tuning.

In some cases it may be impossible to disconnect the motor from the load.

Press the "I" key, and the inverter will display "TEST", and the inverter will tune the motor's parameter in two stages. The motor's stator resistance, rotor resistance and leakage inductance will be stored in F806-F809 automatically (the motor's mutual inductance uses default value generated according to the power), and F800 will be automatically set back to 0. The user may also calculate and input the motor's mutual inductance value manually according to actual motor data. With regard to calculation formula and method, contact Parker for consultation.



When tuning the motor's parameter, motor is not running but it is powered on. Do not touch motor during this process.

*Note:

1. No matter which tuning method of the motor parameters is adopted, set the information of the motor (F801-F805) correctly according to the nameplate of the motor. If the operator is quite familiar with the motor, the operator may input all the parameters (F806-F809) of the motor manually.

2. Parameter F804 can only be checked, not modified.

3. Incorrect motor parameters may result in unstable running of the motor or even failure of normal running. Correct tuning of the parameters is a requirement of vector control performance.

NOTE: Whenever the value of F801 (rated motor power) is changed, Parameters (F806-F809) will automatically be refreshed to default settings. Therefore, be careful while amending this parameter.

The motor's parameters may change when the motor heats up after running for a long time. If the load can be disconnected, we recommend auto-checking before each running.

F810 is rated motor frequency.

When F104=3, and F810=60.00, F802 will change to 460V automatically, F805 will change to 1800 automatically.

When F104=3, and F810=50.00, F802 will change to 380V automatically, F805 will change to 1460 automatically.

When F810 is set to the other values, F802 and F805 will not change automatically.

F802 and F805 can be set manually.

F806	Stator resistance	Setting range: 0.001~65.53Ω (for 22kW and below 22kW) 0.1~6553mΩ (for above 22kW)	Subject to inverter model
F807	Rotor resistance	Setting range: 0.001~65.53Ω (for 22kW and below 22kW) 0.1~6553mΩ (for above 22kW)	Subject to inverter model
F808	Leakage inductance	Setting range: 0.01~655.3mH (for 22kW and below 22kW) 0.001~65.53mH (for above 22kW)	Subject to inverter model
F809	Mutual inductance	Setting range: 0.01~655.3mH (for 22kW and below 22kW) 0.001~65.53mH (for above 22kW)	Subject to inverter model

The set values of F806~F809 will be updated automatically after normal completion of parameter tuning of the motor.

The inverter will restore the parameter values of F806~F809 automatically to default standard parameters of the motor each time after changing F801 rated power of the motor;

If it is impossible to measure the motor in situ, input the parameters manually by referring to the known parameters of a similar motor.

Take a 3.7kW inverter for the example: all data are 3.7kW, 380V, 8.8A, 1440rpm/min, 50Hz, and the load is disconnected. When F800=1, the operation steps are as following:

9-42 Function Parameters

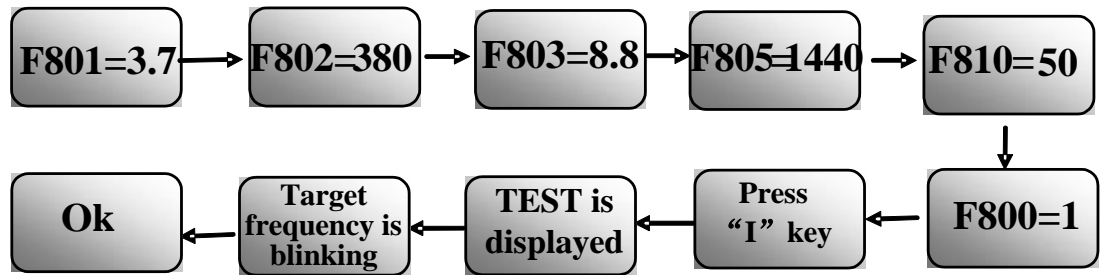

F812	Pre-exciting time	Setting range: 0.000~30.00s	0.30s
F813	Rotary speed loop KP1	Setting range: 0.01~20.00 (for 22kW and below 22kW) 1~100 (for above 22kW)	Subject to inverter model
F814	Rotary speed loop KI1	Setting range: 0.01~2.00 (for 22kW and below 22kW) 0.01~10.00 (for above 22kW)	Subject to inverter model
F815	Rotary speed loop KP2	Setting range: 0.01~20.00 (for 22kW and below 22kW) 1~100 (for above 22kW)	Subject to inverter model
F816	Rotary speed loop KI2	Setting range: 0.01~2.00 (for 22kW and below 22kW) 0.01~10.00 (for above 22kW)	Subject to inverter model
F817	PID switching frequency 1	Setting range: 0~F111	5.00
F818	PID switching frequency 2	Setting range: F817~F111	50.00

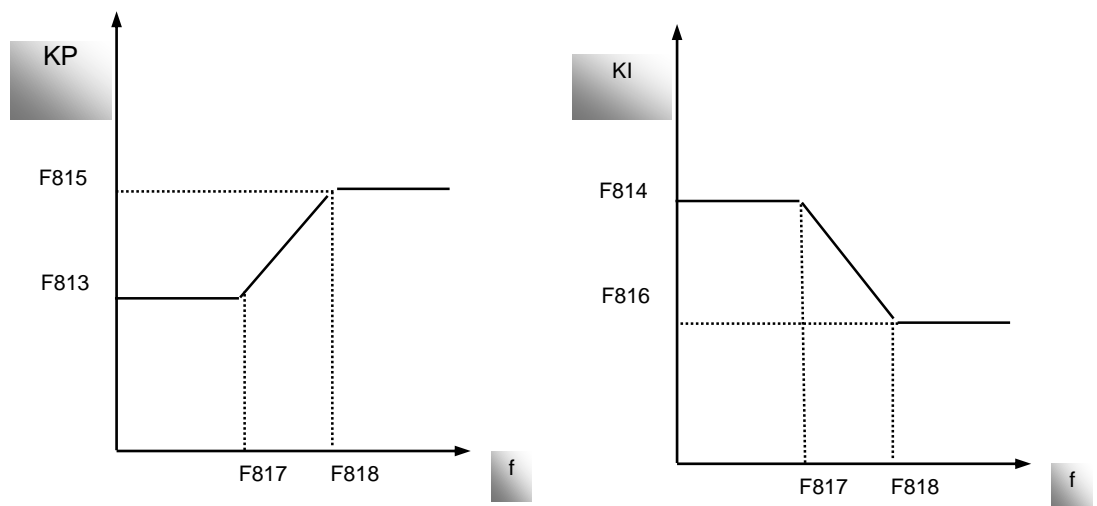

Figure 9-14 PID parameter

Dynamic response of vector control speed can be adjusted through adjusting gains of speed loop. Increasing KP and KI can speed up dynamic response of speed loop. However, if proportional gain or integral gain is too large, it may give rise to oscillation.

Recommended adjusting procedures:

Make fine adjustment of the value starting from the manufacturer value if the manufacturer setting value cannot meet the needs of practical application. Be cautious that amplitude of

adjustment each time should not be too large.

In the event of weak loading capacity or slow rising of rotary speed, increase the value of KP first under the precondition of ensuring no oscillation. If it is stable, increase the value of KI properly to speed up response.

In the event of oscillation of current or rotary speed, decrease KP and KI properly.

In conditions of uncertainty, decrease KP at first, if there is no effect, increase KP. Then adjust KI.

Note: Improper setting of KP and KI may result in violent oscillation of the system, or even failure of normal operation. Set them carefully.

9.9 Communication Parameter

F900 Communication Address	1~255: single inverter address 0: broadcast address	1
F901 Communication Mode	1: ASCII 2: RTU	1
F902 Stop byte	Setting range: 1~2	2
F903 Parity Check	0: None 1: Odd 2: Even	0
F904 Baud Rate(bps)	Setting range: 0: 1200; 1: 2400; 2: 4800; 3: 9600; 4: 19200 5: 38400 6: 57600	3

F904=9600 is recommended for baud rate.

F905 Communication timeout period	Setting range: 0~3000	Mfr's value: 0
-----------------------------------	-----------------------	----------------

When F905 is set to 0.0, the function is invalid. When $F905 \neq 0.0$, if the inverter has not received effective command from PC/PLC during the time set by F905, inverter will trip into CE.

Communication parameters refer Chapter 13 The Default Applications.

9.10 PID Parameters

Internal PID adjusting control is used for simple close-loop system with convenient operation.

FA01 PID adjusting target given source	Setting range: 0: FA04 1: AI1 2: AI2	Mfr's value: 0
--	---	----------------

When FA01=0, PID reference target is given by FA04 or MODBUS.

When FA01=1, PID reference target is given by external analog AI1.

When FA01=2, PID reference target is given by external analog AI2.

9-44 Function Parameters

FA02 PID feedback signal given source	Setting range: 1: AI1 2: AI2	Mfr's value: 1
---------------------------------------	------------------------------------	----------------

When FA02=1, PID reference feedback signal is given by external analog AI1.

When FA02=2, PID reference feedback signal is given by external analog AI2.

FA03 Max limit of PID adjusting (%)	FA04~100.0	Mfr's value: 100.0
FA04 Digital setting value of PID adjusting (%)	FA05~FA03	Mfr's value: 50.0
FA05 Min limit of PID adjusting (%)	0.1~FA04	Mfr's value: 0.0

When FA01=0, the value set by FA04 is digital setting reference value of PID adjusting.

FA06 PID polarity	0: Positive feedback 1: Negative feedback	Mfr's value: 1
-------------------	--	----------------

When FA06=0, the higher feedback value is, the higher the motor speed is. This is positive feedback.

When FA06=1, the lower the feedback value is, the higher the motor speed is. This is negative feedback.

The inverter will restart if the feedback value drops below the value of FA05, PID minimum limit. Therefore, the value of FA05 should be increased from the default value of 0.0 when using the PID sleep function. This is true when FA06 is set to 1. When FA06 is 0 you should set FA03 lower than 100 as the feedback value has to exceed this limit.

FA07 Sleep function selection	Setting range: 0: Enabled 1: Disabled	Mfr's value: 1
-------------------------------	---	----------------

When FA07=0, if inverter runs at the min frequency FA09 for a period time set by FA10, inverter will stop.

When FA07=1, the sleep function is disabled.

FA09 Min frequency of PID adjusting (Hz)	Setting range: F112~F111	Mfr's value: 5.00
--	-----------------------------	-------------------

The min frequency is set by FA09 when PID adjusting is valid.

FA10 Sleep delay time (s)	Setting range: 0~500.0	Mfr's value: 15.0
FA11 Wake delay time (s)	Setting range: 0.0~3000	Mfr's value: 3.0
FA12 Maximum output frequency of PID loop	Setting range: FA09 – F111	Mfr's value: 50.00
FA18 Whether PID adjusting target is changed	0: Invalid 1: Valid	Mfr's value: 1

When FA18=0, PID adjusting target cannot be changed.

FA19	Proportion Gain P	Setting range: 0.00~10.00	Mfr's value: 0.3
FA20	Integration time I (s)	Setting range: 0.1~100.0	Mfr's value: 0.3
FA21	Differential time D (s)	Setting range: 0.0~10.0	Mfr's value: 0.0
FA22	PID sampling period (s)	Setting range: 0.1~10.0	Mfr's value: 0.1

Increasing proportion gain, decreasing integration time and increasing differential time can increase the dynamic response of PID closed-loop system. But if P is too high, I is too low or D is too high, system may be unstable.

PID adjusting period is set by FA22. It affects PID adjusting speed.

The following is PID block diagram.

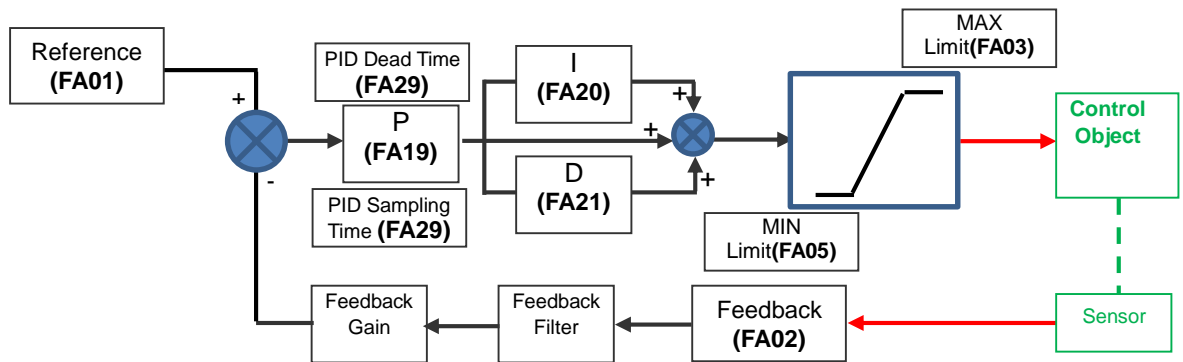

FA29	PID dead time (%)	0.0~10.0	Mfr's value: 2.0
------	-------------------	----------	------------------

FA29, PID dead time has two functions. First, setting dead time can restrain PID adjustor oscillation. The greater this value is, the lighter PID adjustor oscillation is. But if the value of FA29 is too high, PID adjusting precision will decrease. For example: when FA29=2.0 and FA04=70, PID adjusting will not be valid during the feedback value from 68 to 72.

You should try to achieve a critically damped response which allows the mechanics to track as precisely as possible a step change on the setpoint.

- In underdamped systems, the output oscillates and the settling time increases.
- Critically damped systems have no overshoot or oscillations. They reach the setpoint within the desired response time.
- Overdamped systems do not oscillate but do not reach the setpoint within the desired response time.

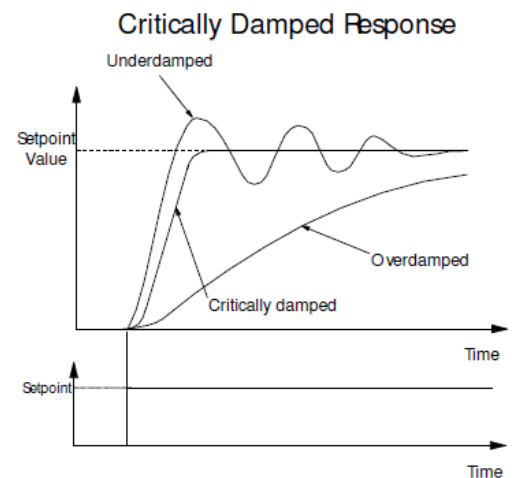

Note: For most applications, derivative gain is not used and is left at its default value of 0.0S

Derivative gain can improve response in some dancer tension controlled systems, particularly those systems with high inertia dancers which need an instantaneous response to overcome the weight of the dancer roll. For loadcell controlled tension systems, derivative gain is almost never used.

9-46 Function Parameters

FA58 Fire pressure given value (%)	Setting range: 0.0~100.0	Mfr's value: 80.0
------------------------------------	-----------------------------	-------------------

FA58 is also called second pressure, when the fire pressure switchover terminal is valid, pressure target value will switch into second pressure value.

FA59 Emergency fire mode	Setting range: 0: Disabled 1: Emergency fire mode 1 2: Emergency fire mode 2	Mfr's value: 0
--------------------------	---	----------------

When emergency fire mode is valid and emergency fire control terminal is valid, fire mode controls are valid and inverter will run at the frequency of FA60 or target frequency until inverter is broken. When OC and OE protection occur, inverter will reset automatically and start running .

Emergency fire mode 1: when the terminal is valid, inverter will run at target frequency.

Emergency fire mode 2: when the terminal is valid, inverter will run at the frequency of FA60.

FA60 Running frequency of emergency fire	Setting range: F112~F111	Mfr's value: 50.0
--	-----------------------------	-------------------

When the emergency fire mode 2 is valid and the emergency fire control terminal is valid, inverter will run at the frequency set by FA60.

FA62 when emergency fire control terminal is invalid	Setting range: 0: inverter can not be stopped manually 1: inverter can be stopped manually	Mfr's value: 0
--	--	----------------

•FA62=0, when emergency fire control terminal (DIx=33) is invalid, before repower or inverter, or reset inverter, inverter can not be stopped manually.

•FA62=1, when emergency fire control terminal (DIx=33) is invalid, after quitting from emergency fire mode, inverter can be stopped manually

9.11 Torque control parameters

FC00 Speed/torque control selection	0: Speed control 1: Torque control 2: Terminal switchover	Mfr's value: 0
-------------------------------------	---	----------------

0: Speed control. Inverter will run by frequency setting. Output torque will automatically match the torque of load, and output torque is limited by max torque (set by manufacture.)

1: Torque control. Inverter will run by torque limit setting. Output speed will run at the speed required to develop the load setpoint. Output speed is limited by max speed (set by FC23 and FC25). Please set the proper torque and speed limits.

2: Terminal switchover. User can set DIx terminal as torque/speed switchover terminal to switch between torque and speed control. When the terminal is true, torque control is enabled. When the terminal is false, speed control is enabled.

FC01	Delay time of torque/speed control switchover (s)	0.0~1.0	0.1
------	---	---------	-----

This function is valid with terminal switchover.

FC02	Torque accel/decel time (s)	0.1~100.0	1
------	-----------------------------	-----------	---

The time is for inverter to run from 0% to 100% of motor rated torque.

FC06	Torque reference source	0: Digital given (FC09) (adjust with keypad) 1: Analog input AI1 2: Analog input AI2	0
FC07	Torque reference coefficient (analogue input)	0~3.000	3.000
FC09	Torque reference command value (%)	0~300.0	100.0

FC07: when input given torque reaches max value, FC07 is the ratio of inverter output torque and motor rated torque. For example, if FC06=1, F402=10.00, FC07=3.00, when AI1 channel output 10V, the output torque of inverter is 3 times of motor rated torque.

FC14	Offset torque reference source	0: Digital given (FC17) (adjust with keypad) 1: Analog input AI1 2: Analog input AI2	0
FC15	Offset torque coefficient	0~0.500	0.500
FC16	Offset torque cut-off frequency (%)	0~100.0	10.0
FC17	Offset torque command value (%)	0~50.0	10.00

Offset torque is used to output larger start torque which equals to setting torque and offset torque when motor drives big inertia load. When actual speed is lower than the setting frequency by FC16, offset torque is given by FC14. When actual speed is higher than the setting frequency by FC16, offset torque is 0.

When FC14≠0, and offset torque reaches max value, FC15 is the ratio of offset torque and motor rated torque. For example: if FC14=1, F402=10.00 and FC15=0.500, when AI1 channel outputs 10V, offset torque is 50% of motor rated torque.

9-48 Function Parameters

FC22	Forward speed limited channel	0: Digital given (FC23) (adjust with keypad) 1: Analog input AI1 2: Analog input AI2	0
FC23	Forward speed limited (%)	0~100.0	10.0
FC24	Reverse speed limited channel	0: Digital given (FC25) (adjust with keypad) 1: Analog input AI1 2: Analog input AI2	0
FC25	Reverse speed limited (%)	0~100.0	10.00

Speed limited FC23/FC25: if given speed reaches max value, they are used to set percent of inverter output frequency and max frequency F111.

FC28	Driving torque limit reference source	0: Digital given (FC30) (adjust with keypad) 1: Analog input AI1 2: Analog input AI2	0
FC29	Driving torque limit coefficient	0~3.000	3.000
FC30	Driving torque limit (%)	0~300.0	200.0
FC31	Re-generating torque limit channel	0: Digital given (FC35) (adjust with keypad) 1: Analog input AI1 2: Analog input AI2	0
FC34	Re-generating torque limit coefficient	0~3.000	3.000
FC35	Re-generating torque limit (%)	0~300.0	200.00

When motor is in the driving status, output torque limit channel is set by FC28, and limit torque is set by FC29.

When motor is in the re-generating status, re-generating torque limit channel is set by FC31, and limit torque is set by FC34.

Chapter 10 Troubleshooting

When the inverter is tripped check what the cause is and rectify as required.

Take counter measures by referring to this manual in case of any malfunctions on inverter. Should it still be unsolved, contact the manufacturer. Never attempt any repairs without due authorization.

Table 10-1 Inverter's Common Cases of Malfunctions

Fault	Description	Causes	Possible Solution
AErr	Line Disconnected	<ul style="list-style-type: none"> * Analog signal line disconnected * Signal source is broken 	<ul style="list-style-type: none"> * Change the signal line * Change the signal source
CE	Communication Timeout	<ul style="list-style-type: none"> * Communication fault 	<ul style="list-style-type: none"> * PC/PLC does not send command at fixed time * Check communication line for reliable connected
Err1	Password is Wrong	<ul style="list-style-type: none"> * When password function is enabled, password is set wrong 	<ul style="list-style-type: none"> * Set password correctly
Err2	Tuning Parameters Wrong	<ul style="list-style-type: none"> * incorrect motor parameters entered 	<ul style="list-style-type: none"> * Connect motor correctly * Enter correct motor data
Err3	Current Malfunction Before Running	<ul style="list-style-type: none"> * Current alarm signal exists before running 	<ul style="list-style-type: none"> * Check if control board is properly connected to power board * Contact Parker
Err4	Current Zero Excursion Malfunction	<ul style="list-style-type: none"> * Flat cable is loosened * Current detector is broken 	<ul style="list-style-type: none"> * Check the flat cable * Contact Parker
Err5	PID Parameters are set Wrong	<ul style="list-style-type: none"> * PID parameters are set wrong. 	<ul style="list-style-type: none"> * Set the parameters correctly
FL	Flycatching Fault	<ul style="list-style-type: none"> * Flycatching failure 	<ul style="list-style-type: none"> * Track again * Contact manufacturer
GP	Ground fault	<ul style="list-style-type: none"> * Motor cable is broken and short-circuit to earth * The insulation of motor is broken and short circuit to earth * Inverter has fault 	<ul style="list-style-type: none"> * Change motor cable * Repair or replace motor * SEE ALSO: OC, OC2 and ERR4
L.U.	Under-Voltage Protection	<ul style="list-style-type: none"> * Low voltage on the input side 	<ul style="list-style-type: none"> * Check if supply voltage is normal * Check if parameter setting is correct
OC/OC2 (Note)	Overcurrent	<ul style="list-style-type: none"> * Too short acceleration time * Short circuit at output side 	<ul style="list-style-type: none"> * Prolong acceleration time * Ask if motor is cable broken * Check if motor overloads
OC1	Overcurrent 1	<ul style="list-style-type: none"> * Locked rotor with motor * Parameter tuning is not correct 	<ul style="list-style-type: none"> * Reduce VVVF compensation value * Measure parameter correctly
O.E.	DC Over-Voltage	<ul style="list-style-type: none"> * Supply voltage too high * Load inertia too big * Deceleration time too short * Motor inertia rise again * Parameter of speed loop PID is set abnormally 	<ul style="list-style-type: none"> * Check if rated voltage is input * Add braking resistance(optional) * Increase deceleration time * Set the parameter of rotary speed loop PID correctly
O.H.	Heatsink Overheat	<ul style="list-style-type: none"> * Environment temperature too high * Poor ventilation * Fan damaged * Carrier wave frequency or compensation curve is too high 	<ul style="list-style-type: none"> * Improve ventilation * Clean air inlet and outlet and radiator * Install as required * Change fan * Decrease carrier wave frequency or compensation curve
O.L1	Inverter Overload	<ul style="list-style-type: none"> * Load too heavy 	<ul style="list-style-type: none"> * Reduce load; *check drive ratio * Increase inverter's capacity

10-2 Troubleshooting

Fault	Description	Causes	Possible Solution
O.L2	Motor Overload	* Load too heavy	* Reduce load; *check drive ratio * Increase motor's capacity
PCE	PMSM tuning fault	* Load is too heavy * Motor parameters measurement is wrong	* Decrease the load * Measure motor parameters correctly
P.F1.	Input Phase Loss	* Phase loss with input power	* Check if power input is normal * Check if parameter setting is correct
PF0	Output Phase Loss	* Motor is broken * Motor wire is loose * Inverter is broken	* Check if wire of motor is loose * Check if motor is broken

Note: No P.F1 protection for single-phase and three-phase under 5.5kW.
Only above 22kW inverters can trip into OC2

Flashing LEDs	Possible Solution
FWD LED Blinking	Inverter is waiting direction command

Table 10-2 Motor Malfunction and Counter Measures

Malfunction	Items to Be Checked	Counter Measures
Motor not Running	Wiring correct? Setting correct? Too big with load? Motor is damaged? Malfunction protection occurs?	Get connected with power Check wiring Checking malfunction Reduce load Check against Table 10-1
Wrong Direction of Motor Running	U, V, W wiring correct? Parameters setting correct?	Correct wiring Set the parameters correctly
Motor Turning but Speed Change not Possible	Wiring correct for lines with given frequency? Correct setting of running mode? Motor overloaded?	Correct wiring Correct setting; Reduce load
Motor Speed Too High or Too Low	Motor's rated value correct? Drive ratio correct? Inverter parameters are set in-corrected? Check if inverter output voltage is abnormal?	Check motor nameplate data Check the setting of drive ratio Check parameters setting Check V/HZ Characteristic value
Motor Running Unstable	Too big load? Too big with load change? Phase loss? Motor malfunction.	Reduce load; reduce load change, increase capacity Correct wiring
Power Trip	Wiring current is too high?	Check input wiring Selecting matching air switch Reduce load Check inverter malfunction

Chapter 11 Technical Specifications

11.1 Selection of Braking Resistance

Supply	Part number	kW	Input current (A)			Output Current (A)	Input protection current	Brake min ohms	Brake Peak A	Brake Continuous A	Brake Power kW	Suggested Resistor	Efficiency %
			230V	380V/400V	460V/480V								
1Ph 220V	10G-11-0015-XX	0.2	4			1.5	6	60	10	5	0.2	80	94%
	10G-11-0025-XX	0.37	5.8			2.5	10						94%
	10G-11-0035-XX	0.55	7.6			3.5	14						94%
	10G-11-0045-XX	0.75	10			4.5	18.1						94%
	10G-12-0050-XX	1.1	10.8			5	24.5						94%
	10G-12-0070-XX	1.5	14			7	25.2						94%
	10G-12-0100-XX	2.2	20			10	32						94%
3Ph 220V	10G-31-0015-XX	0.2	2.5			1.5	5	60	10	5	0.2	80	94%
	10G-31-0025-XX	0.37	3.5			2.5	8.2						94%
	10G-31-0035-XX	0.55	4.5			3.5	10						94%
	10G-31-0045-XX	0.75	5.4			4.5	11.5	50	15	7.5			94%
	10G-32-0050-XX	1.1	5.8			5	18	50	15	7.5			94%
	10G-32-0070-XX	1.5	7.8			7	18.2						94%
	10G-32-0100-XX	2.2	11			10	21.5						94%
	10G-33-0170-XX	4	18.5			17	28	30	30	15	0.4	95	94%
	10G-34-0210-XX	5.5	22			21	33				0.55		94%
	10G-35-0300-XX	7.5	31			30	47	17	50	25	1.1	60	94%
	10G-35-0400-XX	11	41			40	62				1.5		35
	10G-36-0550-XX	15	57			55	86				2	94%	
	3Ph 400V	10G-41-0006-XX	0.2		1.1	0.8	0.6	2.5	120	10	5	0.1	145
10G-41-0010-XX		0.37		1.5	1.2	1	5	94%					
10G-41-0015-XX		0.55		2.1	1.8	1.5	5.5	94%					
10G-42-0020-XX		0.75		3	2.1	2	6.5	0.15				120	94%
10G-42-0030-XX		1.1		4	3.2	3	10.2						94%
10G-42-0040-XX		1.5		5	4.2	4	11						94%
10G-42-0065-XX		2.2		7.5	7.0	6.5	15						94%
10G-43-0080-XX		3.7		10.5	8.3	8	18	100	15	7.5	0.4	120	94%
10G-43-0090-XX		4		11	9.2	9	21				0.55		94%
10G-43-0120-XX		5.5		14	11.5	12	29				0.75		94%
10G-44-0170-XX		7.5		18.5	16	17	34	50	25	12.5	1.1	60	97%
10G-44-0230-XX		11		24	21	23	46.5				1.5		35
10G-45-0320-XX		15		36.5	27	32	80				2	35	
10G-45-0380-XX		18.5		44	31	38	90	25Ω	50	32	3kW		25Ω
10G-45-0440-XX		22		51	35	44	100	25Ω	50	32	4kW	25Ω	97%
10G-46-0600-XX		30		70	53	60	110	18Ω	75	45	4.5kW	18Ω	97%
10G-47-0750-XX		37		80	64	75	120	18Ω	75	45	5.5kW	18Ω	98%
10G-47-0900-XX		45		94	75	90	150	16Ω	100	50	7.5kW	16Ω	98%
10G-48-1100-XX		55		120	85	110	180	9Ω	150	88	9kW	9Ω	98%
10G-48-1500-XX		75		160	115	150	240	9Ω	150	88	11kW	9Ω	98%
10G-49-1800-XX		90		190	130	180	285	5.5Ω	300	150	13.5kW	5.5Ω	98%
10G-49-2200-XX		110		225	170	220	340	4Ω	400	200	16kW	4Ω	98%
10G-410-2650-XX		132		275	210	265	400	4Ω	400	200	18kW	4Ω	98%
10G-411-3200-XX	160		330	250	320	500							
10G-411-3600-BF	180		370	280	360	550							

Chapter 12 Modbus Communication

12.1 General

Modbus is a serial and asynchronous communication protocol. Modbus protocol is a general language applied to PLC and other controlling units. This protocol has defined an information structure which can be identified and used by a controlling unit regardless of whatever network they are transmitted.

You can read reference books or ask for the details of MODBUS from manufactures.

Modbus protocol does not require a special interface while a typical physical interface is RS485.

NOTE: The AC10 cannot be a Modbus master.

12.2 Modbus Protocol

12.2.1 Transmission mode

Format

ASCII mode

Start	Address	Function	Data				LRC check		End	
: (0X3A)	Inverter Address	Function Code	Data Length	Data 1	...	Data N	High-order byte of LRC	Low- order byte of LRC	Return (0X0D)	Line Feed (0X0A)

RTU mode

Start	Address	Function	Data	CRC check		End
T1-T2-T3-T4	Inverter Address	Function Code	N data	Low-order byte of CRC	High-order byte of CRC	T1-T2-T3-T4

12.2.2 ASCII Mode (F901=1)

In ASCII mode, one Byte (hexadecimal format) is expressed by two ASCII characters.

For example, 31H (hexadecimal data) includes two ASCII characters '3(33H)', '1(31H)'.

Common characters, ASCII characters are shown in the following table:

Characters	'0'	'1'	'2'	'3'	'4'	'5'	'6'	'7'
ASCII Code	30H	31H	32H	33H	34H	35H	36H	37H
Characters	'8'	'9'	'A'	'B'	'C'	'D'	'E'	'F'
ASCII Code	38H	39H	41H	42H	43H	44H	45H	46H

12.2.3 RTU Mode (F901=2)

In RTU mode, one Byte is expressed by hexadecimal format. For example, 31H is delivered to data packet.

12.3 Baud rate F904

Setting range: 1200, 2400, 4800, 9600, 19200, 38400, 57600

12.4 Frame structure:

ASCII mode

Byte	Function
1	Start Bit (Low Level)
7	Data Bit
0/1	Parity Check Bit (None for this bit in case of no checking. Otherwise 1 bit)
1/2	Stop Bit (1 bit in case of checking, otherwise 2 bits)

RTU mode

Byte	Function
1	Start Bit (Low Level)
8	Data Bit
0/1	Parity Check Bit (None for this bit in case of no checking. Otherwise 1 bit)
1/2	Stop Bit (1 bit in case of checking, otherwise 2 bits)

12.5 Error Check

12.5.1 ASCII mode

Longitudinal Redundancy Check (LRC): It is performed on the ASCII message field contents excluding the 'colon' character that begins the message, and excluding the CRLF pair at the end of the message.

The LRC is calculated by adding together successive 8-bit bytes of the message, discarding any carries, and then two's complementing the result.

A procedure for generating an LRC is:

1. Add all bytes in the message, excluding the starting 'colon' and ending CRLF. Add them into an 8-bit field, so that carries will be discarded.
2. Subtract the final field value from FF hex (all 1's), to produce the ones-complement.
3. Add 1 to produce the twos-complement.

12.5.2 RTU Mode

Cyclical Redundancy Check (CRC): The CRC field is two bytes, containing a 16-bit binary value.

The CRC is started by first preloading a 16-bit register to all 1's. Then a process begins of applying successive 8-bit bytes of the message to the current contents of the register. Only the eight bits of data in each character are used for generating the CRC. Start and stop bits, and the parity bit, do not apply to the CRC.

A procedure for generating a CRC-16 is:

1. Load a 16-bit register with FFFF hex (all 1's). Call this the CRC register.
2. Exclusive OR the first 8-bit byte of the message with the high-order byte of the 16-bit CRC register, putting the result in the CRC register.
3. Shift the CRC register one bit to the right (toward the LSB), zero-filling the MSB. Extract and examine the LSB.
4. (If the LSB was 0): Repeat Step 3 (another shift).
- (If the LSB was 1): Exclusive OR the CRC register with the polynomial value A001 hex (1010 0000 0000 0001).
5. Repeat Steps 3 and 4 until 8 shifts have been performed. When this is done, a complete 8-bit byte will have been processed.

When the CRC is appended to the message, the low-order byte is appended first, followed by the high-order byte.

12-3 Modbus Communication

12.5.3 Protocol Converter

It is easy to turn a RTU command into an ASCII command followed by the lists:

1. Use the LRC replacing the CRC.
2. Transform each byte in RTU command into a corresponding two byte ASCII. For example: transform 0x03 into 0x30, 0x33 (ASCII code for 0 and ASCII code for 3).
3. Add a 'colon' (:) character (ASCII 3A hex) at the beginning of the message.
4. End with a 'carriage return – line feed' (CRLF) pair (ASCII 0D and 0A hex).

So we will introduce RTU Mode in followed part. If you use ASCII mode, you can use the up lists to convert.

12.6 Command Type & Format

The listing below shows the function codes.

Code	Name	Description
03	Read Holding Registers	Read the binary contents of holding registers in the slave. (Less than 10 registers at a time)
06	Write Single Register	Preset a value into holding register

12.6.1 Address and meaning

The part introduces inverter running, inverter status and related parameters setting.

Description of rules of function codes parameters address:

- i) Use the function code as parameter address

General Series:

High-order byte: 01~0A (hexadecimal)

Low-order byte: 00~50 (max range) (hexadecimal) Function code range of each partition is not the same. For the specific range refer to manual.

For example: parameter address of F114 is 010E (hexadecimal).

parameter address of F201 is 0201 (hexadecimal).

Note: in this situation, it allows to read six function codes and write only one function code.

Some function codes can only be checked but cannot be modified; some function codes can neither be checked nor be modified; some function codes cannot be modified in run state; some function codes cannot be modified both in stop and run state.

In case parameters of all function codes are changed, the effective range, unit and related instructions refer to user manual for related series of inverters. Otherwise, unexpected results may occur.

- ii) Use different parameters as parameter address

(The above address and parameters descriptions are in hexadecimal format, for example, the decimal digit 4096 is represented by hexadecimal 1000).

12.6.2 Running Status Parameters

Parameters Address	Parameter Description (read only)
1000	Output frequency
1001	Output voltage
1002	Output current
1003	Pole numbers/ control mode, high-order byte is pole numbers, low-order byte is control mode.
1004	Bus voltage
1005 ----AC10	Drive ratio/inverter status High-order byte is drive ratio, low-order byte is inverter status Inverter status: 0X00: Standby mode 0X01: Forward running 0X02: Reverse running 0X04: Over-current (OC) 0X05: DC over-current (OE) 0X06: Input Phase loss (PF1) 0X07: Frequency Over-load (OL1) 0X08: Under-voltage (LU) 0X09: Overheat (OH) 0X0A: Motor overload (OL2) 0X0B: Interference (Err) 0X0C: LL 0X0D: External Malfunction (ESP) 0X0E: Err1 0X0F: Err2 0X10: Err3 0X11: Err4 0X12: OC1 0X13: PF0 0X14: Analog disconnected protection (AErr) 0X19: PID parameters are set incorrectly (Err5) 0X2D: Communication timeout (CE) 0X2E: Flycatching fault (FL) 0X31: Watchdog fault (Err6)
1006	The percent of output torque
1007	Inverter radiator temperature
1008	PID given value
1009	PID feedback value

12-5 Modbus Communication

Reading parameter address	Function	Remarks
100A	Read integer power value	The integer power value is read by PC.
100B	DI terminal status	DI1~DI8—bit0~bit7
100C	Terminal output status	bit0-OUT1 bit2-fault relay
100D	AI1	0~4095 read input analog digital value
100E	AI2	0~4095 read input analog digital value
1010	Reserved	
1011	Reserved	
1012	Reserved	
1013	Present-stage speed value 0000 : no function 0001 : stage speed 1 0010 : stage speed 2 0011 : stage speed 3 0100 : stage speed 4 0101 : stage speed 5 0110 : stage speed 6 0111 : stage speed 7 1000 : stage speed 8 1001 : stage speed 9 1010 : stage speed 10 1011 : stage speed 11 1100 : stage speed 12 1101 : stage speed 13 1110 : stage speed 14 1111 : stage speed 15	Monitoring in which stage speed inverter is. (Valid when F500 = 1 or F500 = 2)
1014	Reserved	
1015	AO1 (0~100.00)	Monitoring analog output percent
1016	AO2 (0~100.00)	Monitoring analog output percent
1017	Current speed	Monitoring current speed.
1018	Read accurate power value	Correct the power to 1 decimal place.

12.6.3 Control commands

Parameters Address	Parameters Description (write only)
2000	Command meaning: 0001: Forward running (no parameters) 0002: Reverse running (no parameters) 0003: Deceleration stop 0004: Free stop 0005: Forward jogging start 0006: Forward jogging stop 0007: Fault reset 000A: Forward jogging stop

	000B: Reverse jogging stop
2001	Lock parameters 0001: Unlock System (remote control locked) 0002: Lock remote control (any remote control commands are not valid before unlocking) 0003: RAM and EEprom are permitted to be written. 0004: Only RAM is permitted to be written, EEprom is prohibited being written.

Writing parameter address	Function	Remarks
2002	AO1 output percent is set by PC/PLC. Setting range: 0~1000	F431=7 AO1 token output analog is controlled by PC/PLC.
2003	AO2 output percent is set by PC/PLC. Setting range: 0~1000	F432=7 AO2 token output analog is controlled by PC/PLC.
2004	Reserved	
2005	Multi-function output terminal DO1	1 means token output is true. 0 means token output is false.
2006	Multi-function output terminal DO2	
2007	Relay output terminal	

12.6.4 Illegal Response When Reading Parameters

Command Description	Function	Data
Slave parameters response	The highest-order byte changes into 1.	Command meaning: 0001: Illegal function code 0002: Illegal address 0003: Illegal data 0004: Slave fault ^{note 2}

Note 2: Illegal response 0004 appears below two cases:

Do not reset inverter when inverter is in the malfunction state.

Do not unlock inverter when inverter is in the locked state.

Additional Remarks

Expressions during communication process:

Parameter Values of Frequency=actual value X 100

Parameter Values of Time=actual value X 10

Parameter Values of Current=actual value X 100

Parameter Values of Voltage=actual value X 1

Parameter Values of Power (100A)=actual value X 1

Parameter Values of Power (1018)=actual value X 10

Parameter Values of Drive Ratio=actual value X 100

Parameter Values of Version No. =actual value X 100

Instruction: Parameter value is the value sent in the data package. Actual value is the actual value of inverter. After PC/PLC receives the parameter value, it will divide the corresponding coefficient to get the actual value.

NOTE: Take no account of radix point of the data in the data package when PC/PLC transmits command to inverter. The valid value is range from 0 to 65535.

12-7 Modbus Communication

12.7 Function Codes Related to Communication

Function Code	Function Definition	Setting Rang	Mfr's Value
F200	Source of start command	0: Keypad command; 1: Terminal command; 2: Keypad+ Terminal; 3: MODBUS; 4: Keypad+ Terminal+ MODBUS	4
F201	Source of stop command	0: Keypad command; 1: Terminal command; 2: Keypad+ Terminal; 3: MODBUS; 4: Keypad+ Terminal+ MODBUS	4
F203	Main frequency source X	0: Digital setting memory; 1: External analog AI1; 2: External analog AI2; 3: Reserved 4: Stage speed control; 5: No memory by digital setting; 6:Reserved; 7: Reserved; 8: Reserved; 9: PID adjusting; 10: MODBUS	0
F900	Inverter Address	1~255	1
F901	Modbus Mode Selection	1: ASCII mode 2: RTU mode	1
F903	Parity Check	0: Invalid 1: Odd 2: Even	0
F904	Baud Rate(bps)	0: 1200 1: 2400 2: 4800 3: 9600 4: 19200 5: 38400 6: 57600	3
F905	Communication Timeout	0.0~3000.0	0.0

Set the functions code related to communication consonant with the PLC/PC communication parameters, when inverter communicates with PLC/PC.

12.8 Physical Interface

12.8.1 Interface instruction

The RS485 communication interface is located on the control terminals, marked A+ and B-

12.8.2 Structure of Field Bus

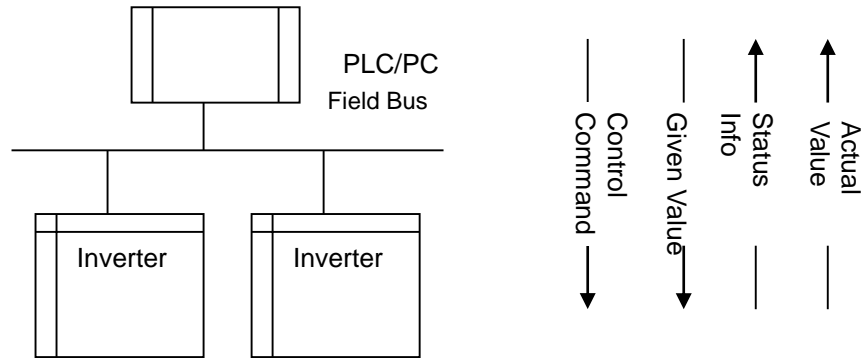

Connecting Diagram of Field Bus

RS485 Half-duplex communication mode is adopted for AC10 series inverter. Daisy chain structure is adopted by 485 Bus-line. Do not use 'spur' lines or a star configuration. Reflect signals which are produced by spur lines or star configuration will interfere in 485 communications.

Note that for the same time in half-duplex connection; only one inverter can have communication with PC/PLC. Should two or more than two inverters upload data at the same time, then bus competition will occur, which will not only lead to communication failure, but higher current to certain elements as well.

12.9 Grounding and Terminal

Terminal resistance of $120\ \Omega$ will be adopted for terminal of RS485 network, to diminish the reflection of signals. Terminal resistance shall not be used for intermediate network.

No direct grounding shall be allowed for any point of RS485 network. All the equipment in the network shall be well grounded via their own grounding terminal. Please note that grounding wires will not form closed loop in any case.

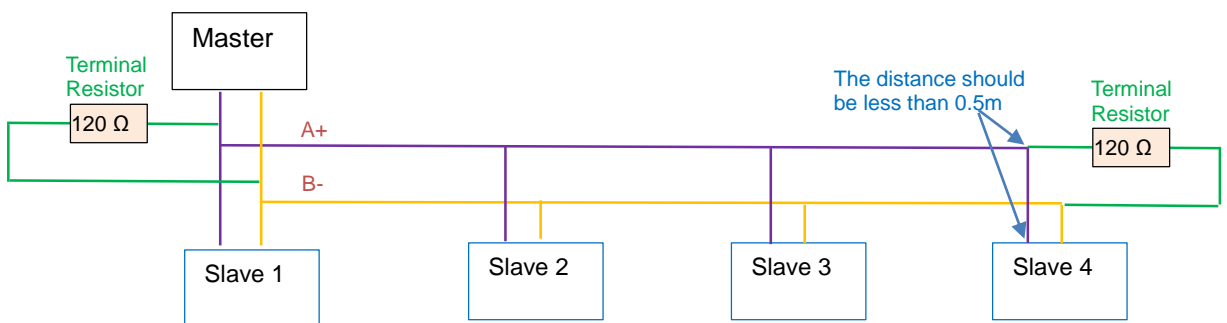

Connecting Diagram of Terminal Resistance

Check the drive capacity of PC/PLC and the distance between PC/PLC and inverter when wiring. Add a repeaters if drive capacity is not enough.



All wiring connections for installation shall have to be made when the inverter is disconnected from power supply.

12-9 Modbus Communication

12.9.1 Examples

Example1: In RTU mode, change acc time (F114) to 10.0s in NO.01 inverter.

Query

Address	Function	Register Address Hi	Register Address Lo	Preset Data Hi	Preset Data Lo	CRC Lo	CRC Hi
01	06	01	0E	00	64	E8	1E

Function code F114 Value: 10.0S

Normal Response

Address	Function	Register Address Hi	Register Address Lo	Response Data Hi	Response Data Lo	CRC Lo	CRC Hi
01	06	01	0E	00	64	E8	1E

Function code F114 Normal Response

Abnormal Response

Address	Function	Abnormal code	CRC Lo	CRC Hi
01	86	04	43	A3

The max value of function code is 1. Slave fault

Example 2: Read output frequency, output voltage, output current and current rotate speed from NO.2 inverter.

Host Query

Address	Function	First Register Address Hi	First Register Address Lo	Register count Hi	Register count Lo	CRC Lo	CRC Hi
02	03	10	00	00	04	40	FA

Communication Parameters Address 1000H

Slave Response:

Address	Function	Byte Count	Data Hi	Data Lo	Data Hi	Data Lo	Data Hi	Data Lo	Data Hi	Data Lo	Crc Lo	Crc Hi
02	03	08	13	88	01	90	00	3C	02	00	82	F6

Output Frequency Output Voltage Output Current Numbers of Pole Pairs Control Mode

NO.2 Inverter's output frequency is 50.00Hz, output voltage is 380V, output current is 0.6A, numbers of pole pairs are 2 and control mode keypad control.

Example 3: No.1 Inverter runs forwardly.

Host Query:

Address	Function	Register Hi	Register Lo	Write status Hi	Write status Lo	CRC Lo	CRC Hi
01	06	20	00	00	01	43	CA

Communication parameters address 2000H

Forward running

Slave Normal Response:

Address	Function	Register Hi	Register Lo	Write status Hi	Write status Lo	CRC Lo	CRC Hi
01	06	20	00	00	01	43	CA

Normal Response

Slave Abnormal Response:

Address	Function	Abnormal Code	CRC Lo	CRC Hi
01	86	01	83	A0

The max value of function code is 1. Illegal function code (assumption)

Example 4: Read the value of F113, F114 from NO.2 inverter

Host Query:

Address	Function	Register Address Hi	Register Address Lo	Register Count Hi	Register Count Lo	CRC Lo	CRC Hi
02	03	01	0D	00	02	54	07

Communication Parameter Address F10DH

Numbers of Read Registers

Slave Normal Response:

Address	Function	Byte count	The first parameters status Hi	The first parameters status Lo	The second parameters status Hi	The second parameters status Lo	CRC Lo	CRC Hi
02	03	04	03	E8	00	78	49	61

The actual value is 10.00.

The actual value is 12.00.

Slave Abnormal Response:

Address	Function Code	Abnormal Code	CRC Lo	CRC Hi
02	83	08	B0	F6

The max value of function code is 1.

Parity check fault

13-1 The Default Applications

chapter 13 The Default Applications

The drive is supplied with 5 Applications, Application 0 to Application 5. Please refer to following:

Application 1 is the factory default application, providing for basic speed control.

Application 2 supplies speed control using a manual or auto set-point.

Application 3 supplies speed control using preset speeds.

Application 4 supplies speed control using terminal.

Application 5 supplies speed control using PID.

Control wiring of application



Normally open push-button



2-position switch



Normally open contact (relay)

The default application is 0 this gives complete access to all operating lists in this manual, to select one of the default control application macros, set parameter F228 1 – 5.

13.1 Application 1: Basic Speed Control (F228 = 1)

Standard parameters

- F228 Application
- F111 Max frequency
- F112 Min frequency
- F114 Accel time
- F115 Decel Time
- F803 Motor rated current
- F810 Motor rated frequency
- F124 Jog setpoint
- F209 Stop mode
- F137 Torque compensation
- F138 Linear compensation
- F108 Password
- F160 Reset to default values

Application 1:

Basic Speed Control

- DIAGNOSTICS = F131
- Frequency Hz = 0
- Analog Input V = 4
- Motor Current A = 2

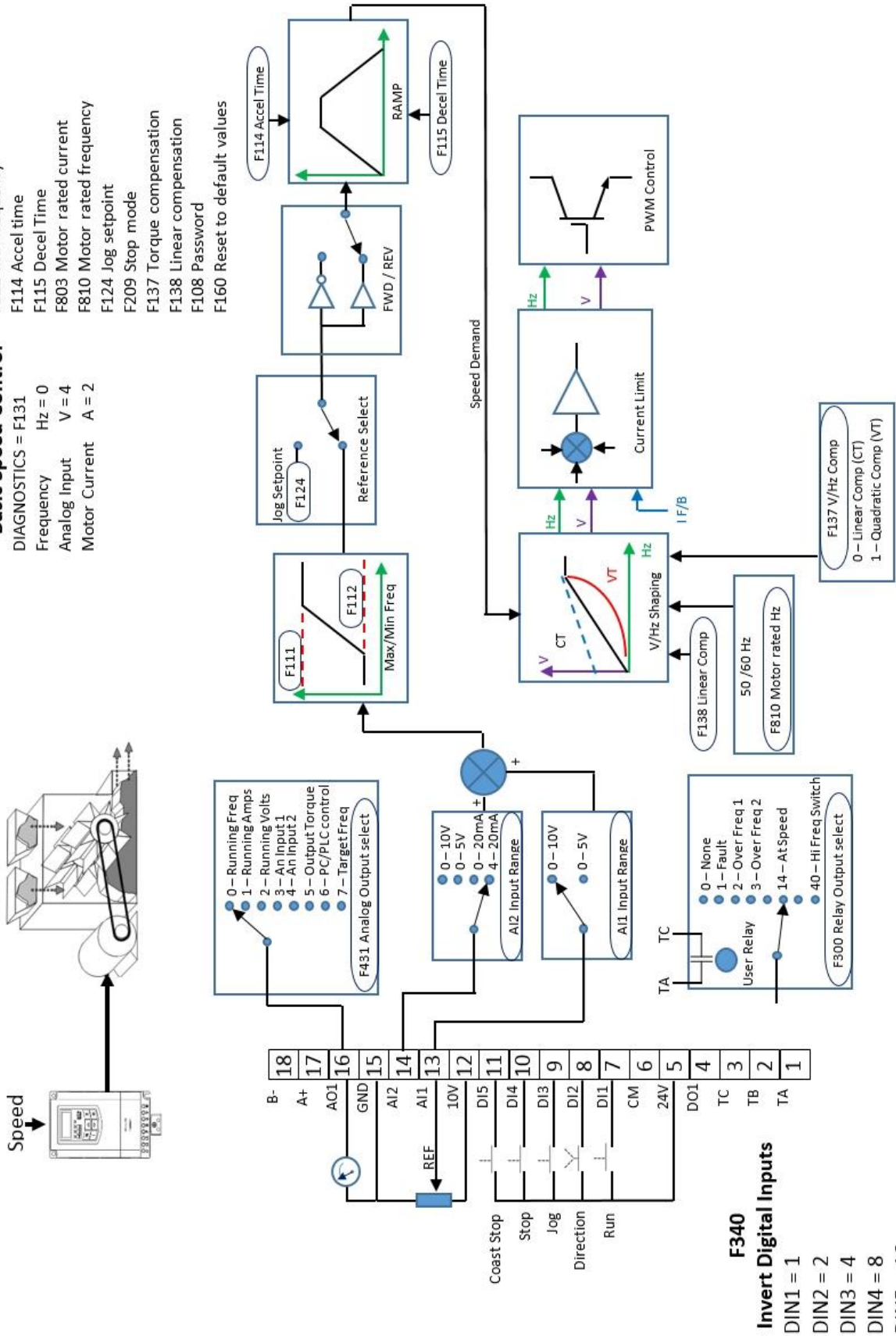

F340

- Invert Digital Inputs
- DIN1 = 1
 - DIN2 = 2
 - DIN3 = 4
 - DIN4 = 8
 - DIN5 = 16

13-3 The Default Applications

This Application is ideal for general purpose applications. The set-point is the sum of the two analogue inputs AI1 and AI2, providing Speed Set-point + Speed Secondary capability.

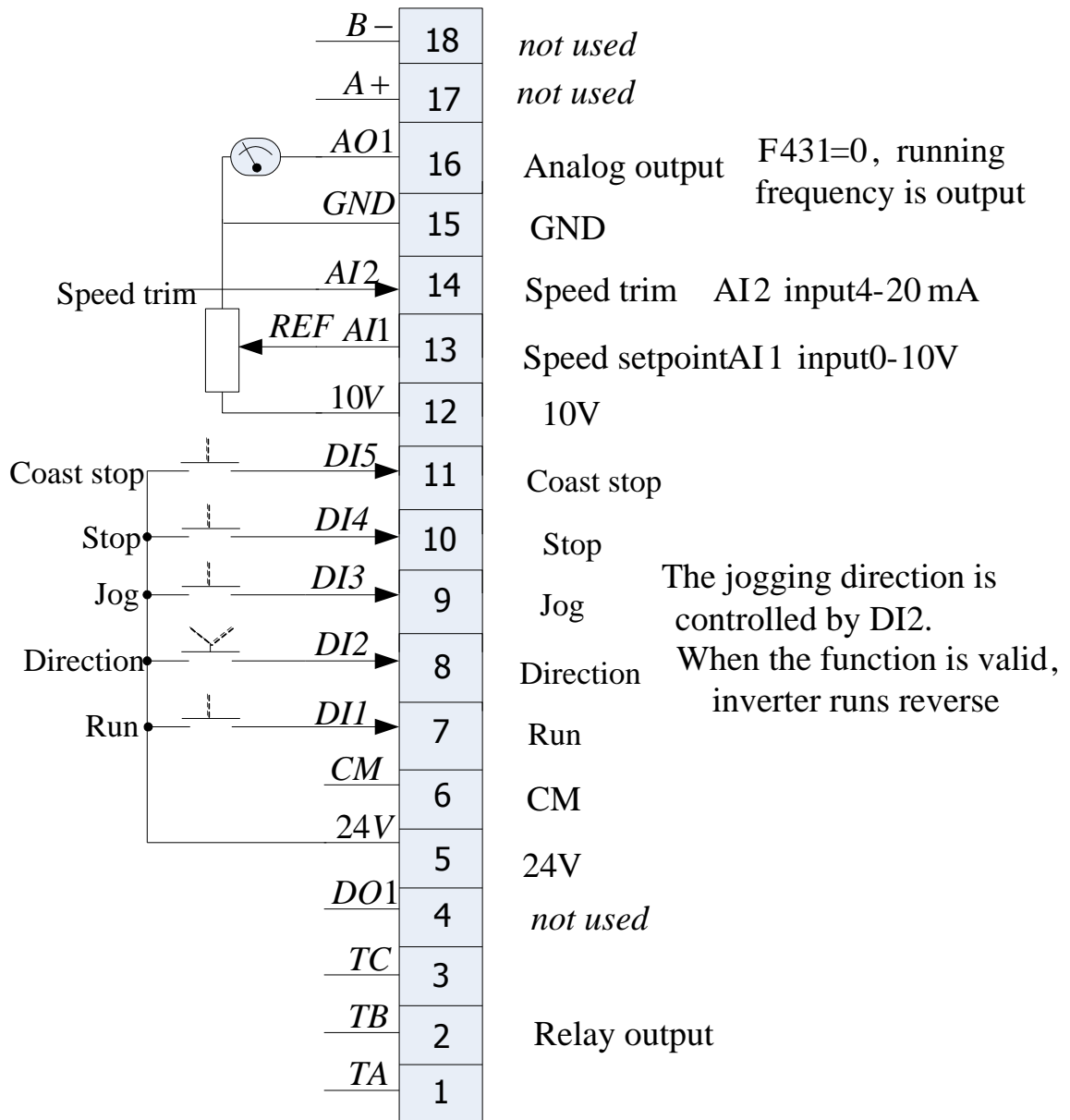

Function setting	Setting value
F228 Macro selection	1: Basic speed control
F106 Control mode	2: VF control
F203 Main frequency source X	1: AI1
F204 Accessorial frequency source Y	2: AI2
F207 Frequency source selecting	1: X+Y
F316 DI1 terminal function setting	1: Running terminal
F317 DI2 terminal function setting	58: Direction
F318 DI3 terminal function setting	52: Jogging terminal (no direction)
F319 DI4 terminal function setting	2: Stop terminal
F320 DI5 terminal function setting	8: Free stop terminal
F431 AO1 analog output signal selecting	0: Running frequency

13.2 Application 2 : Auto/Manual Control (F228 = 2)

Standard parameters

- F228 Application
- F111 Max frequency
- F112 Min frequency
- F114 Accel time
- F115 Decel Time
- F803 Motor rated current
- F810 Motor rated frequency
- F124 Jog setpoint
- F209 Stop mode
- F137 Torque compensation
- F138 Linear compensation
- F108 Password
- F160 Reset to default values

**Application 2:
Auto/Manual Control**

- DIAGNOSTICS = F131
- Frequency Hz = 0
- Analog Input V = 4
- Motor Current A = 2

Ideal for automatic control applications with limit switches or proximity sensors

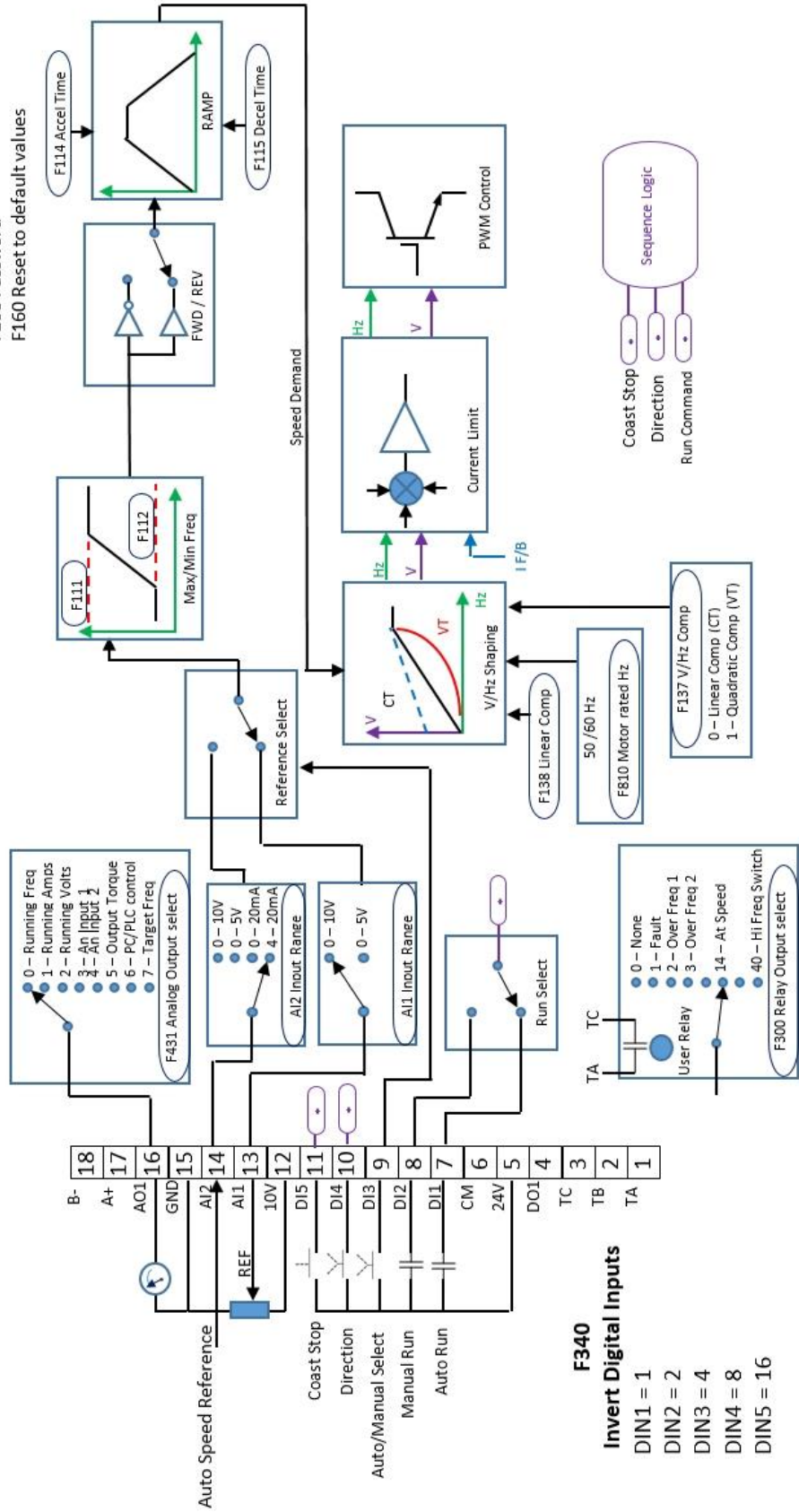
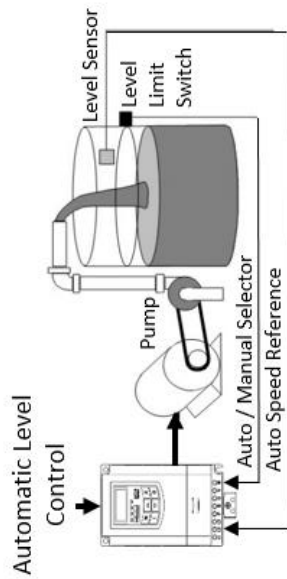

F340

Invert Digital Inputs

- DIN1 = 1
- DIN2 = 2
- DIN3 = 4
- DIN4 = 8
- DIN5 = 16

13-5 The Default Applications

Two Run inputs and two Set-point inputs are provided. The Auto/Manual switch selects which pair of inputs is active. The Application is sometimes referred to as Local/Remote.

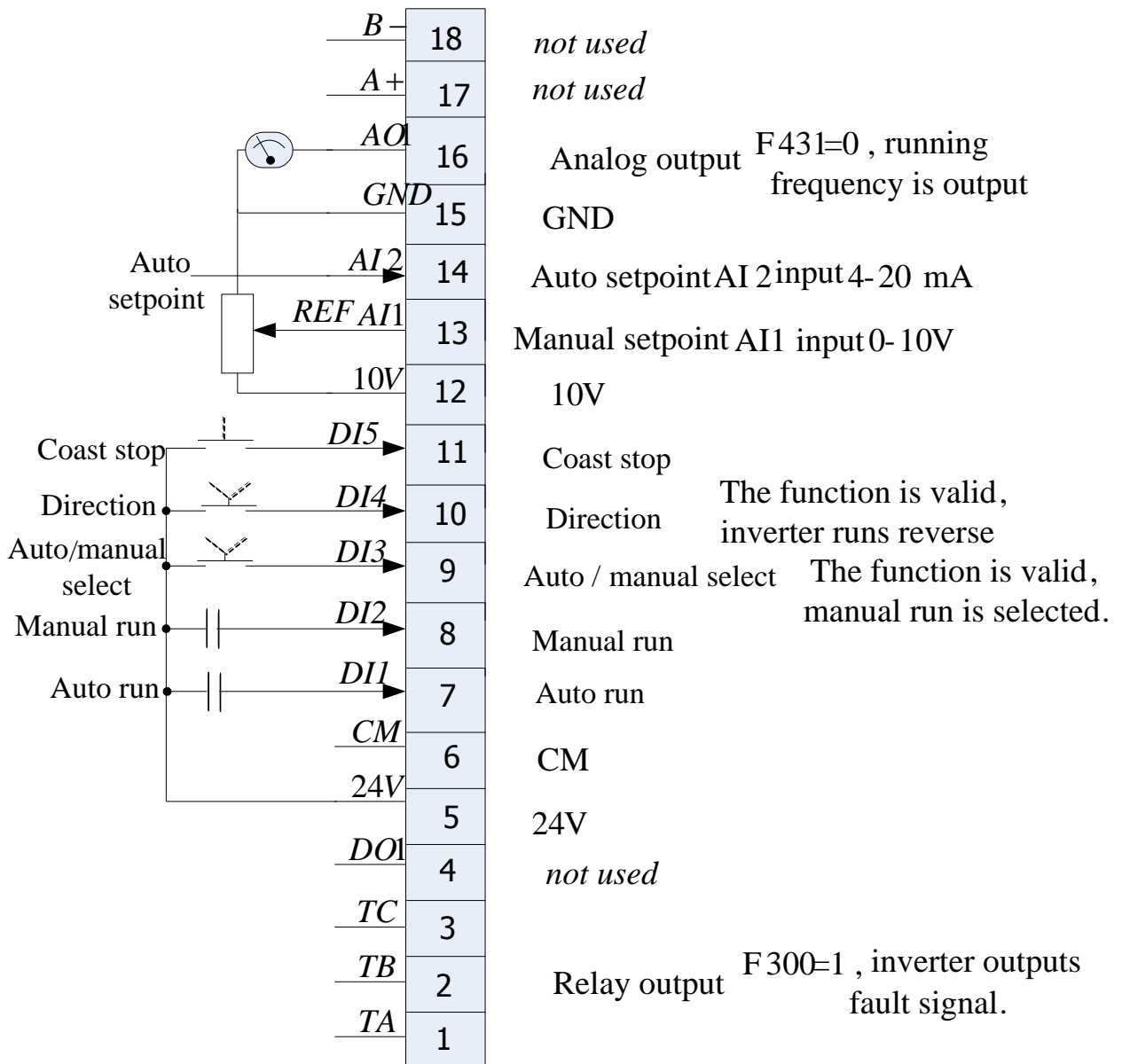

Function setting	Setting value
F228 Macro selection	2: Auto/manual control
F106 Control mode	2: VF control
F203 Main frequency source X	1: AI1
F204 Accessorial frequency source Y	2: AI2
F207 Frequency source selecting	2: X or Y
F316 DI1 terminal function setting	56: Manual running
F317 DI2 terminal function setting	57: Auto running
F318 DI3 terminal function setting	55: Auto /manual switchover
F319 DI4 terminal function setting	58: Direction
F320 DI5 terminal function setting	8: Free stop
F431 AO1 analog output signal selecting	0: Running frequency

13.3 Application 3: Preset Speeds (F228 = 3)

Standard parameters

- F228 Application
- F111 Max frequency
- F112 Min frequency
- F114 Accel time
- F115 Decel Time
- F803 Motor rated current
- F810 Motor rated frequency
- F124 Jog setpoint
- F209 Stop mode
- F137 Torque compensation
- F138 Linear compensation
- F108 Password
- F160 Reset to default values

Application 3:

Preset Speeds Control

- DIAGNOSTICS = F131
- Frequency Hz = 0
- Analog Input V = 4
- Motor Current A = 2

Ideal for applications requiring multiple discrete speed levels

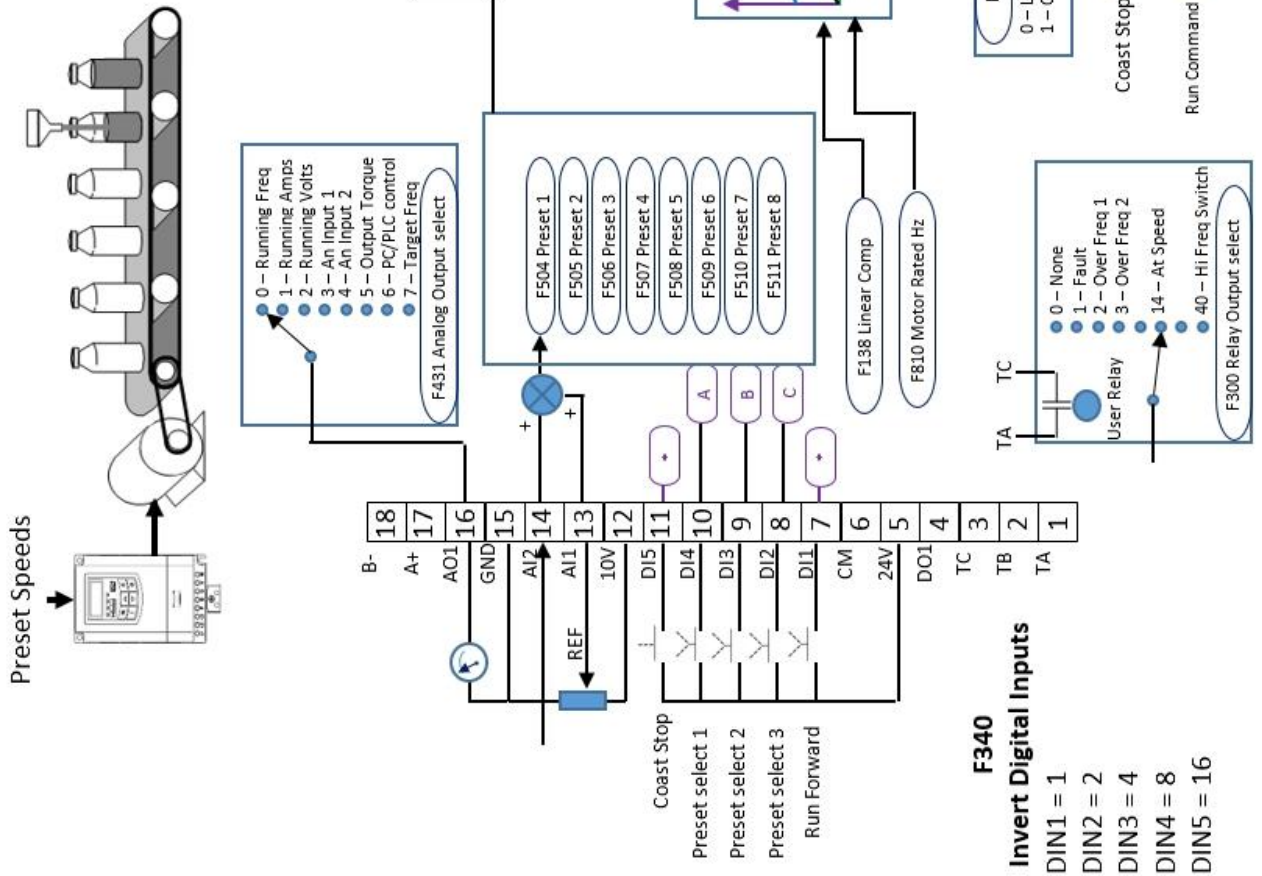

A	B	C	PRESET	FWD	REV
0V	0V	0V	1	549=0	549=1
0V	0V	24V	2	550=0	550=1
0V	24V	0V	3	551=0	551=1
0V	24V	24V	4	552=0	552=1
24V	0V	0V	5	553=0	553=1
24V	0V	24V	6	554=0	554=1
24V	24V	0V	7	555=0	555=1
24V	24V	24V	8	556=0	556=1

F340

Invert Digital Inputs

- DIN1 = 1
- DIN2 = 2
- DIN3 = 4
- DIN4 = 8
- DIN5 = 16

13-7 The Default Applications

This is ideal for applications requiring multiple discrete speed levels.

The set-point is selected from either the sum of the analogue inputs, or as one of up to eight other pre-defined speed levels. These are selected using DI2, DI3 and DI4, refer to the Truth Table below.

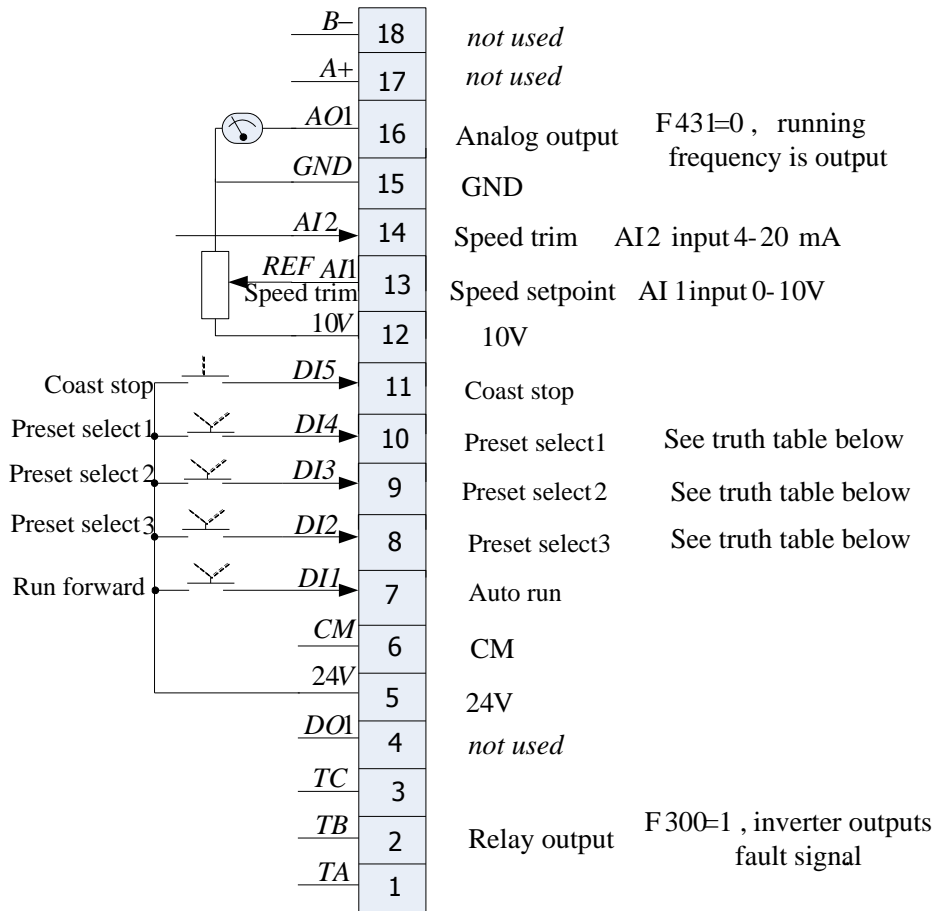

Preset Speed Truth Table

Preset Select 1 DI4	Preset Select 2 DI3	Preset Select 3 DI2	Preset
0V	0V	0V	1
0V	0V	24V	2
0V	24V	0V	3
0V	24V	24V	4
24V	0V	0V	5
24V	0V	24V	6
24V	24V	0V	7
24V	24V	24V	8

Function setting	Setting value
F228 Macro selection	3: Preset Speeds
F106 Control mode	2: VF control
F203 Main frequency source X	4: Multi-stage speed control
F204 Accessorial frequency source Y	1: AI1
F207 Frequency source selecting	1: X+Y
F316 DI1 terminal function setting	56: Manual running
F317 DI2 terminal function setting	3: Mutiple stage speed 1
F318 DI3 terminal function setting	4: Mutiple stage speed 2
F319 DI4 terminal function setting	5: Mutiple stage speed 3
F320 DI5 terminal function setting	8: Free stop
F431 AO1 analog output signal selecting	0: Running frequency

13.4 Application 4 : Raise/Lower Secondary (F228 = 4)

Standard parameters

- F228 Application
- F111 Max frequency
- F112 Min frequency
- F114 Accel time
- F115 Decel Time
- F803 Motor rated current
- F810 Motor rated frequency
- F124 Jog setpoint
- F209 Stop mode
- F137 Torque compensation
- F138 Linear compensation
- F108 Password
- F160 Reset to default values

Application 4:

Raise / Lower Control

- DIAGNOSTICS = F131
- Frequency Hz = 0
- Analog Input V = 4
- Motor Current A = 2

Ideal for applications requiring speed control from multiple locations

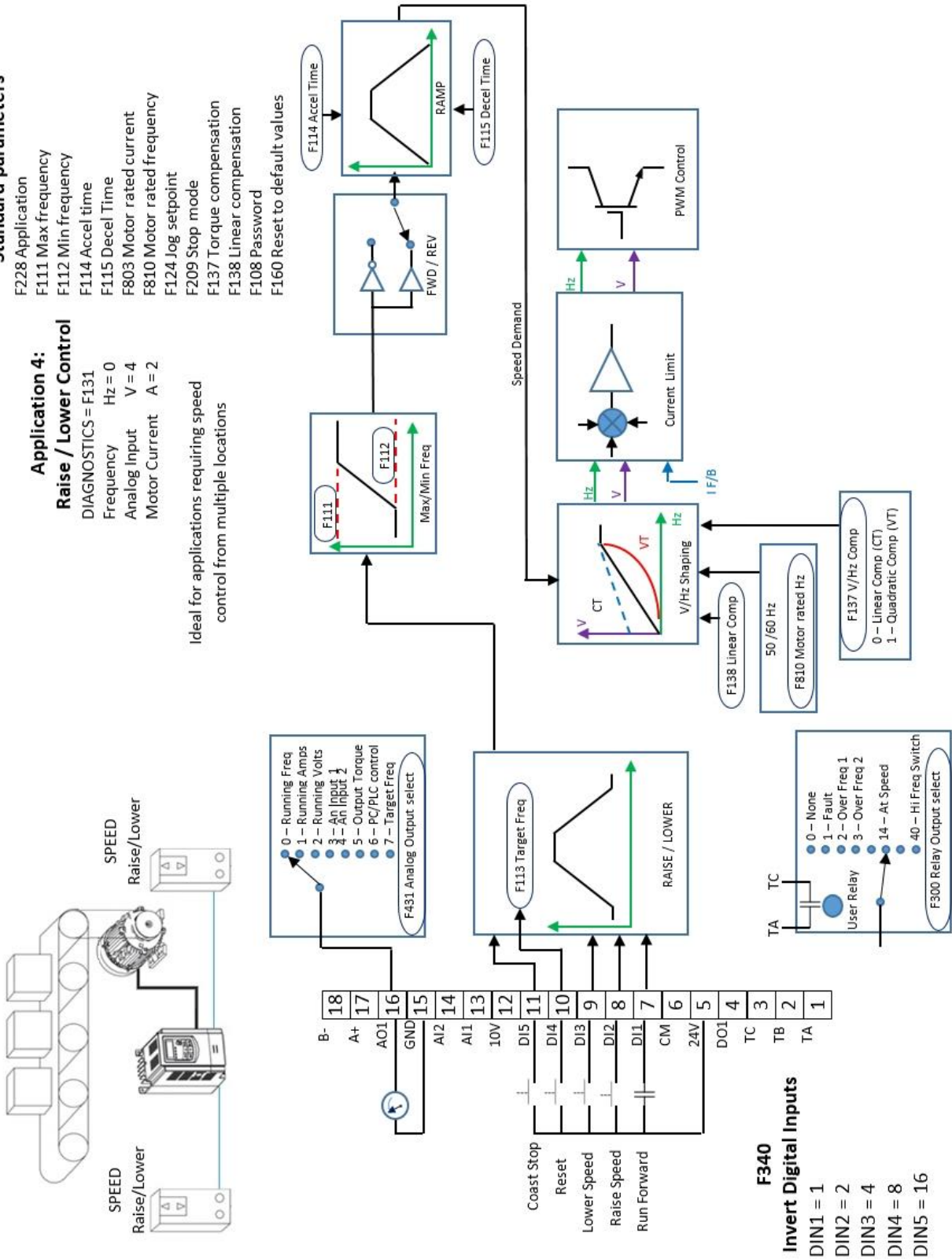

F340

- Invert Digital Inputs**
- DIN1 = 1
 - DIN2 = 2
 - DIN3 = 4
 - DIN4 = 8
 - DIN5 = 16

13-9 The Default Applications

This Application mimics the operation of a motorised potentiometer. Digital inputs allow the set-point to be increased and decreased between limits. The Application is sometimes referred to as motorised Potentiometer.

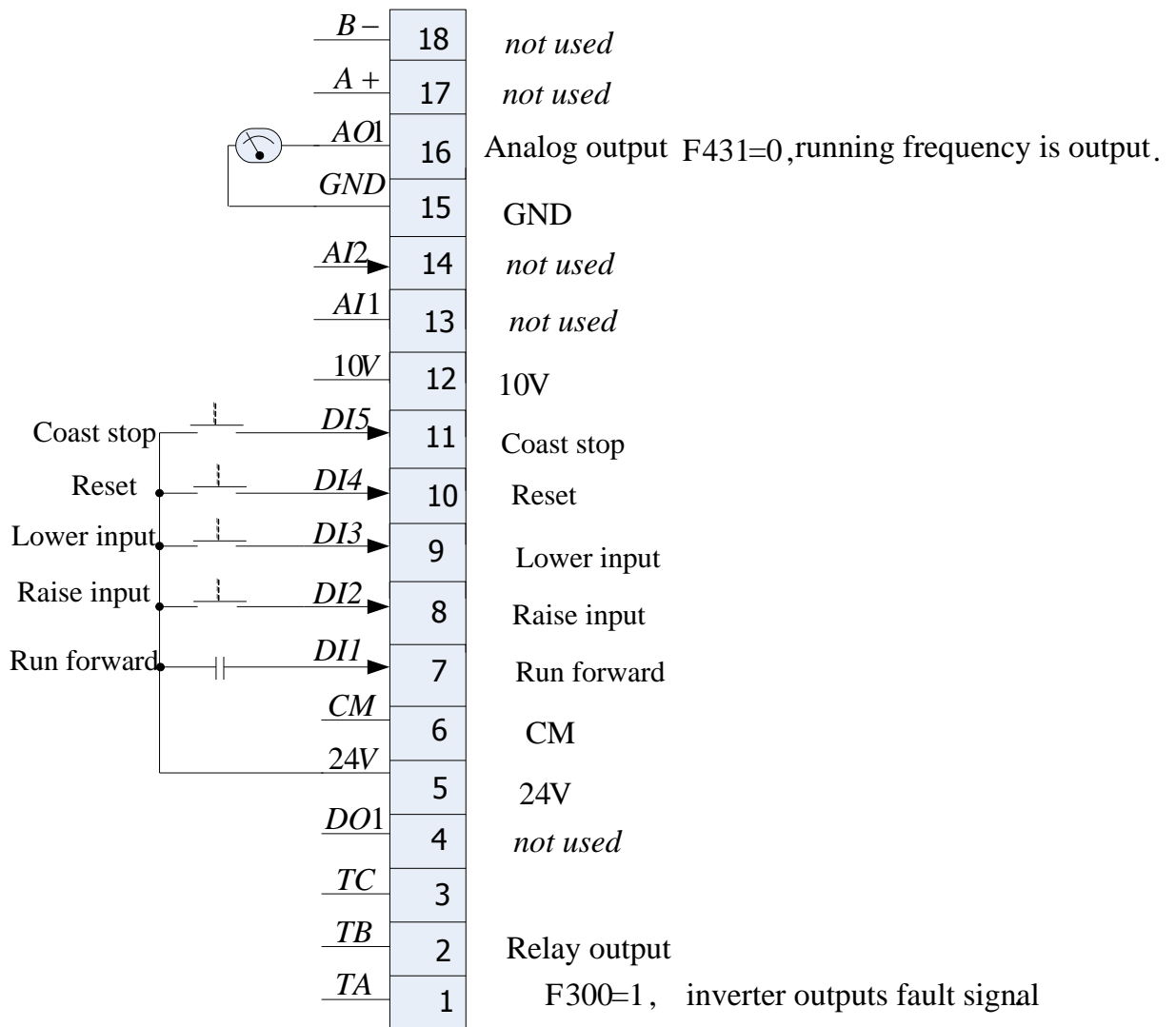

Function setting	Setting value
F228 Macro selection	4: Raise/Lower
F106 Control mode	2: VF control
F112 Min Frequency	Min frequency is 0.00Hz.
F113 Target frequency	Target frequency is 0.00Hz.
F224 when target frequency is lower than Min frequency	1: When target frequency is lower than Min frequency, inverter will run at Min frequency.
F203 Main frequency source X	0: Digital setting memory
F208 Terminal two-line/three-line operation selecting	1: Two-line operation mode 1
F316 DI1 terminal function setting	15: FWD terminal
F317 DI2 terminal function setting	13: UP frequency increasing
F318 DI3 terminal function setting	14: DOWN frequency decreasing
F319 DI4 terminal function setting	54: Frequency reset
F320 DI5 terminal function setting	8: Free stop
F431 AO1 analog output signal selecting	0: Running frequency

13.5 Application 5: PID (F228 = 5)

Standard parameters

- F228 Application
- F111 Max frequency
- F112 Min frequency
- F114 Accel time
- F115 Decel Time
- F803 Motor rated current
- F810 Motor rated frequency
- F124 Jog setpoint
- F209 Stop mode
- F137 Torque compensation
- F138 Linear compensation
- F108 Password
- F160 Reset to default values

Application 5: PID Control

- DIAGNOSTICS = F131
- Frequency Hz = 0
- Analog Input V = 4
- Motor Current A = 2

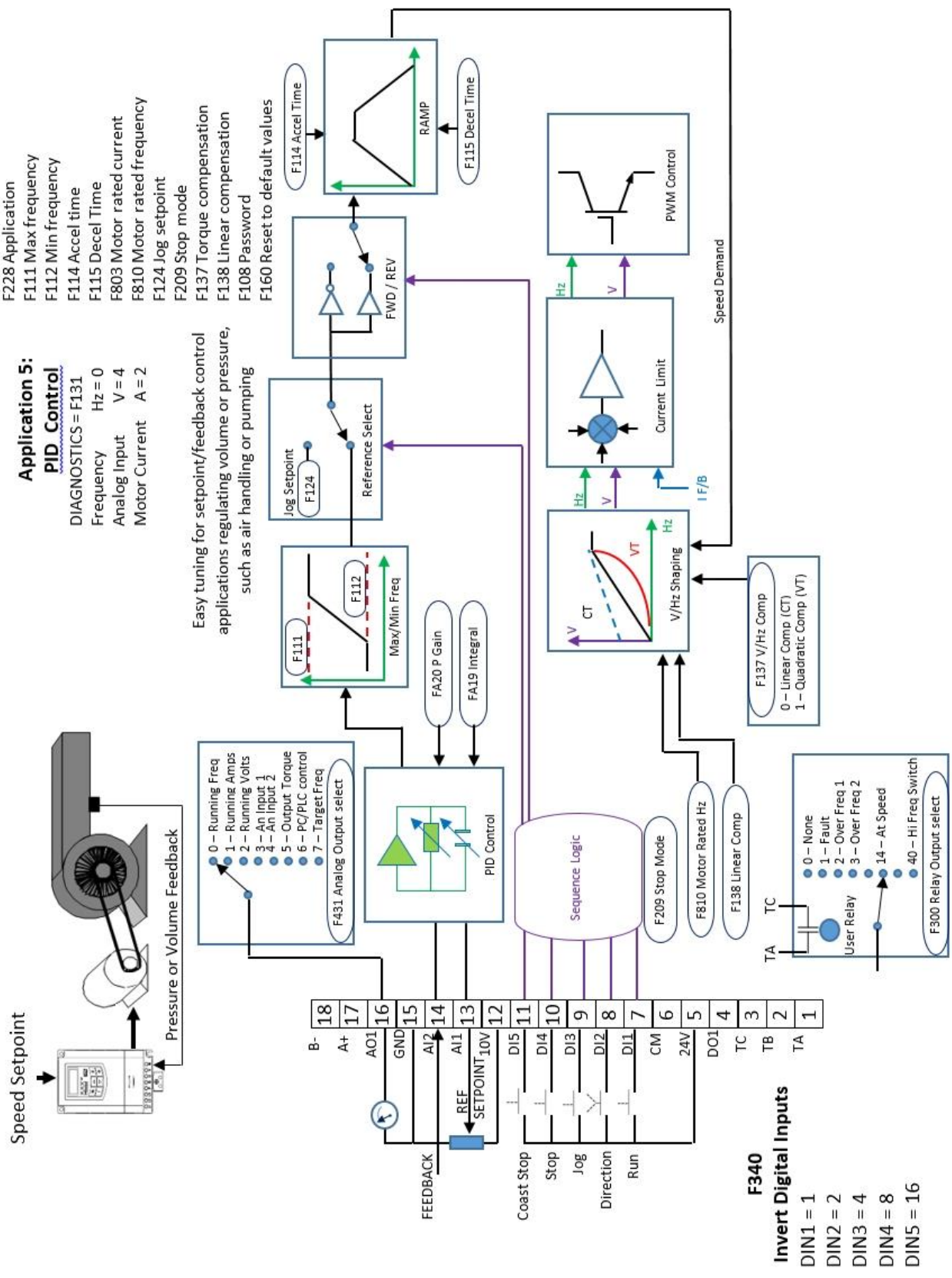

Easy tuning for setpoint/feedback control applications regulating volume or pressure, such as air handling or pumping

F340 Invert Digital Inputs

- DIN1 = 1
- DIN2 = 2
- DIN3 = 4
- DIN4 = 8
- DIN5 = 16

13-11 The Default Applications

A simple application using a Proportional-Integral-Derivative 3-term controller. The set-point is taken from AI1, with feedback signal from the process on AI2. The difference between these two signals is taken as the PID error. The output of the PID block is then used as the drive set-point.

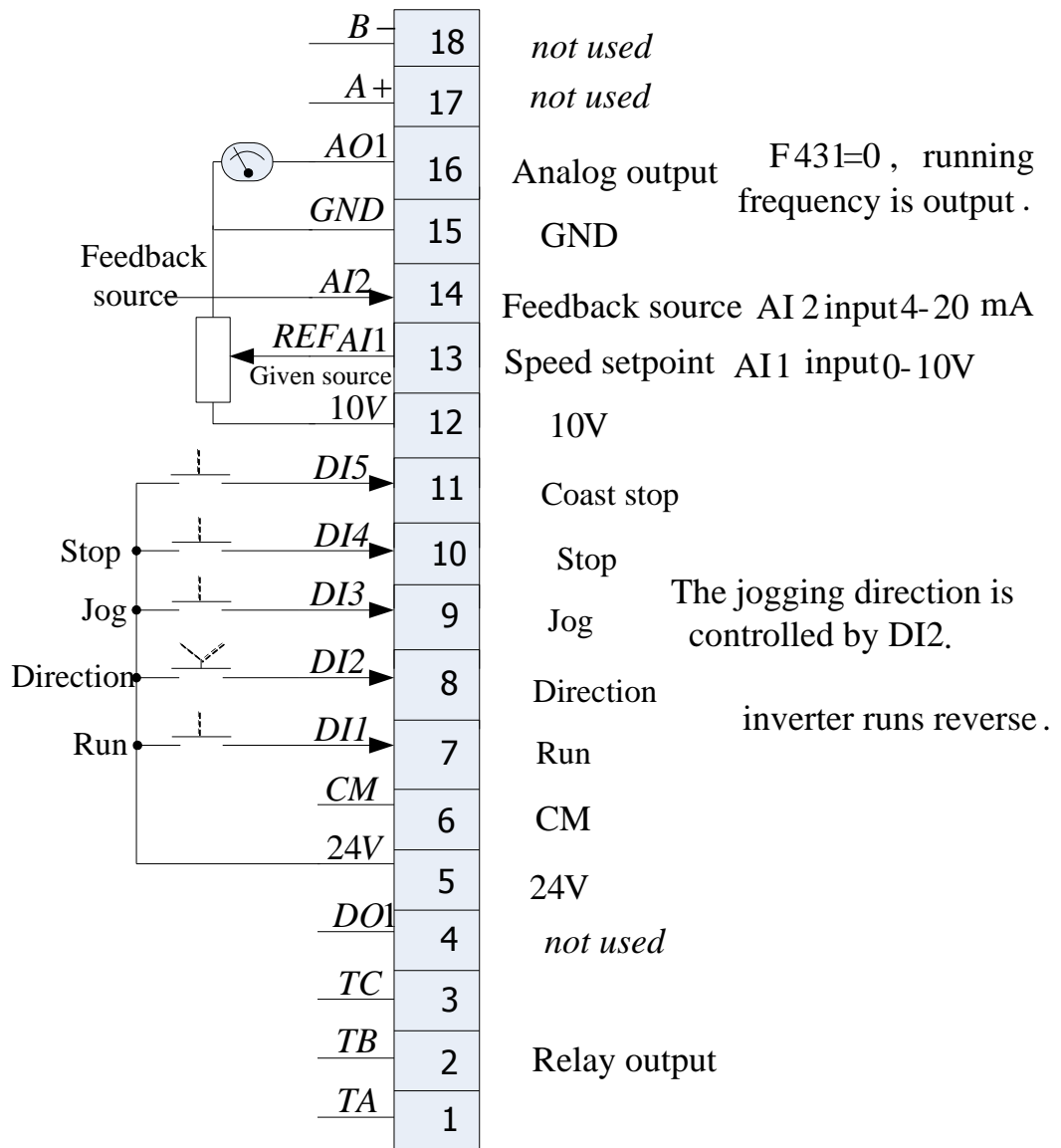

Function setting	Setting value
F228 Macro selection	5: PID control
F106 Control mode	2: VF control
F203 Main frequency source X	9: PID control
F316 DI1 terminal function setting	1: Running terminal
F317 DI2 terminal function setting	58: Forward running
F318 DI3 terminal function setting	52: Direction
F319 DI4 terminal function setting	2: Stop
F320 DI5 terminal function setting	8: Free stop
F431 AO1 analog output signal selecting	0: Running frequency
FA01 PID adjusting target given source	1: AI1
FA02 PID adjusting feedback given source	2: AI2

Chapter 14 Compliance

This Chapter outlines the compliance requirements and product certifications.

 <p>Attention – hot surfaces</p>	 <p>DANGER Risk of electric shock</p>	 <p>Caution Refer to documentation</p>	 <p>Earth/Ground Protective Conductor Terminal</p>
--	---	--	--

14.1 Applicable Standards

EN 61800-3:2004 Adjustable speed electrical power drive systems – Part 3: EMC requirements and specific test methods.

EN 61800-5-1:2007 Adjustable speed electrical power drive systems – Part 5-1: Safety requirements – Electrical, thermal and energy.

EN 60204-1:2006 Safety of machinery – Electrical equipment of machines – Part 1: General requirements.

EN 61000-3-2:2006 Electromagnetic Compatibility (EMC) - Part 3-2: Limits – Limits for harmonic current emissions (equipment input current up to and including 16A per phase).

IEC 61000-3-12:2011 Electromagnetic compatibility (EMC) – Part 3-12: Limits – Limits for harmonic currents produced by equipment connected to public low-voltage systems with input currents >16A and ≤75A per phase.

EN 61000-6-2:2007 Electromagnetic compatibility (EMC) – Part 6-2: General standards – Immunity for industrial environments.

EN 61000-6-3:2007 Electromagnetic compatibility (EMC) – Part 6-3: General standards - Emission standard for residential, commercial and light-industrial environments.

EN 61000-6-4:2007 Electromagnetic compatibility (EMC) – Part 6-4: General standards – Emission standard for residential, commercial and light-industrial environments.

UL508C Standard for Safety, Power Conversion Equipment, third edition.

CSA 22.2 No.14-13 Industrial Control Equipment

NFPA National Electrical Code, National Fire Protection Agency, Part 70

RESTRICTION, EVALUATION, AUTHORISATION AND RESTRICTION OF CHEMICALS (REACH)

The Regulation (EC) No 1907/2006 of the European Parliament and of the Council of 18 December 2006 concerning the Registration, Evaluation, Authorization, and Restriction of Chemicals (REACH) entered into force on June 1, 2007. Parker agrees with the purpose of REACH which is to ensure a high level of protection of human health and the environment. Parker is compliant with all applicable requirements of REACH.

As of 19th December 2011 VSD products manufactured and marketed by Parker do not contain substances on the REACH SVHC candidate list in concentrations greater than 0.1% by weight per article. Parker will continue to monitor the developments of the REACH legislation and will communicate with our customers according to the requirement above.

14-2 Compliance

14.2 European Compliance

CE Marking



The CE marking is placed upon the product by Parker Hannifin Manufacturing Ltd to facilitate its free movement within the European Economic Area (EEA). The CE marking provides a presumption of conformity to all applicable directives. Harmonized standards are used to demonstrate compliance with the essential requirements laid down in those relevant directives.

It must be remembered that there is no guarantee that combinations of compliant components will result in a compliant system. This means that compliance to harmonised standards will have to be demonstrated for the system as a whole to ensure compliance with the directive.



Local wiring regulations always take precedence.

Where there are any conflicts between regulatory standards for example earthing requirements for electromagnetic compatibility, safety shall always take precedence.

14.2.1 Low Voltage Directive

When installed in accordance with this manual the product will comply with the low voltage directive 2006/95/EC.



Protective Earth (PE) Connections

Only one protective earth  conductor is permitted at each protective earth terminal contacting point.

The product requires a protective earth conductor cross section of at least 10mm², where this is not possible a second protective ground terminal provided on the VSD (Variable Speed Drive) shall be used. The second conductor should be independent but electrically in parallel.

14.2.2 EMC Directive

When installed in accordance with this manual the product will comply with the electromagnetic compatibility directive 2004/108/EC.

The following information is provided to maximise the Electro Magnetic Compatibility (EMC) of VSDs and systems in their intended operating environment, by minimising their emissions and maximising their immunity.

14.2.3 Machinery Directive

When installed in accordance with this manual the product will comply with the machinery directive 2006/42/EC.

This product is classified under category 21 of annex IV as 'logic units to ensure safety functions'. All instructions, warnings and safety information can be found in Chapter 6. This product is a component to be incorporated into machinery and may not be operated alone. The complete machinery or installation using this equipment may only be put into service when all safety considerations of the Directive are fully implemented. Particular reference should be made to EN60204-1 (Safety of Machinery - Electrical Equipment of Machines).



14.2.4 EMC Compliance

WARNING

In a domestic environment, this product may cause radio interference, in which case supplementary mitigation measures may be required.



Definitions

Category C1

PDS (Power Drive System) of rated voltage less than 1000V, intended for use in the first environment

Category C2

PDS (Power Drive System) of rated voltage less than 1000V, which is neither a plug in device nor a movable device and, when used in the first environment, is intended to be installed and commissioned only by a professional.

Note: A professional is a person or an organisation having necessary skills in installing and/or commissioning power drive systems, including their EMC aspects.

Category C3

PDS (Power Drive System) of rated voltage less than 1000V, intended for use in the second environment and not intended for use in the first environment.

Category C4

PDS (Power Drive System) of rated voltage equal to or above 1000V, or rated current equal to or above 400A, or intended for use in complex systems in the second environment.

First Environment

Environment that include domestic premises, it also includes establishments directly connected without transformers to a low-voltage power supply network which supplies buildings used for domestic purposes.

Note: Houses, apartments, commercial premises or offices in a residential building are examples of first environment locations.

Second Environment

Environment that includes all establishments other than those directly connected to a low-voltage power supply network which supplies buildings used for domestic purposes.

Note: Industrial areas, technical areas of any building fed from a dedicated transformer are examples of second environment locations.

14.3 EMC Standards Comparison

The standards are concerned with two types of emission

Radiated Those in the band 30MHz – 1000MHz which radiate into the environment

Conducted Those in the band 150kHz – 30MHz which are injected into the supply.

14.3.1 Radiated

The standards have common roots (CISPR 11 & CISPR14) so there is some commonality in the test levels applied in different environments.

Relationship Between Standards

Standards			Limits*
Product Specific	Generic		
EN 61800-3	EN61000-6-3	EN61000-6-4	
Category C1	Equivalent	Not applicable	30 – 230MHz 30dB(µV/m) 230 - 1000MHz 37dB(µV/m)
Category C2	Not applicable	Equivalent	30 – 230MHz 40dB(µV/m) 230 - 1000MHz 47dB(µV/m)
Category C3	These limits have no relationships with the generic standards.		30 – 230MHz 50dB(µV/m) 230 - 1000MHz 60dB(µV/m)

*Adjusted for 10m

14-4 Compliance

Radiated Emissions Profile

EN61800-3 - Limits for electromagnetic radiation disturbance in the frequency band 30 MHz to 1000 MHz

Frequency band MHz	Category C1	Category C2
	Electric field strength component Quasi-peak dB(√V/m)	Electric field strength component Quasi-peak dB(√V/m)
30 ≤ f ≤ 230	30	40
230 < f ≤ 1 000	37	47

NOTE: Measurement distance 10 m.

For category C1, if the field strength measurement at 10 m cannot be made because of high ambient noise levels or for other reasons, measurement may be made at 3 m. If the 3 m distance is used, the measurement result obtained shall be normalised to 10 m by subtracting 10 dB from the result. In this case, care should be taken to avoid near field effects, particularly when the PDS (Power Drive System) is not of an appropriately small size, and at frequencies near 30 MHz.

When multiple drives are used 3dB attenuation per drive needs to be added.

AC10 EMC COMPLIANCE

Standard EN 61800-3		230V 1PH Unfiltered	230V 1PH Filtered	230V 3PH Unfiltered	230V 3PH Filtered	400V 3PH Unfiltered	400V 3PH Filtered	
Conducted emissions	Category C1	Product supplied as a component, a suitable external filter is required		Product supplied as a component, a suitable external filter is required		Product supplied as a component, a suitable external filter is required		
	Category C2	Product supplied as a component, a suitable external filter is required		Product supplied as a component, a suitable external filter is required		Product supplied as a component, a suitable external filter is required		
	Category C3 <i>Where I ≤ 100A</i>	When fitted with an external filter. Max cable length 30 meters	When fitted with an internal filter. Max cable length 30 meters	When fitted with an external filter. Max cable length 30 meters	When fitted with an internal filter. Max cable length 30 meters	When fitted with an external filter. Max cable length 30 meters	When fitted with an internal filter. Max cable length 30 meters	
Radiated Emissions	Category C3	No specific enclosure required						
Cable Requirements	Power Supply	Cable Type	Unscreened					
		Segregation	From all other wiring (clean)					
		Length Limit	Unlimited					
	Motor Cable	Cable Type	Screened/Armoured					
		Segregation	From all other wiring (noisy)					
		Screen to Earth	Both ends					
		Max Cable Length	30 meters					
	External Filter to Drive	Cable Type	Screened/Armoured					
		Segregation	From all other wiring (noisy)					
		Length Limit	0.3 meters					
		Screen to Earth	Both ends					

14.4 North American & Canadian Compliance Information (Frame 1 – 5 ONLY)

14.4.1 UL Standards

The UL/cUL mark applies to products in the United States and Canada and it means that UL has performed product testing and evaluation and determined that their stringent standards for product safety have been met. For a product to receive UL certification, all components inside that product must also receive UL certification:



14.4.2 UL Standards Compliance

This drive is tested in accordance with UL standard UL508C, File No. E142140 and complies with UL requirements. To ensure continued compliance when using this drive in combination with other equipment, meet the following conditions:

1. Do not install the drive to an area greater than pollution severity 2 (UL standard).
2. Installation and operating instructions shall be provided with each device.

The following markings shall appear in one of the following locations; shipped separately with the device; on a separable, self-adhesive permanent label that is shipped with the device; or anywhere on the device itself.

- a) Designation markings for each wiring diagram.
- b) Markings for proper wiring connections.
- c) “Maximum surrounding air temperature 40°C” or equivalent.
- d) “Solid state motor overload protection reacts when reaches 150% of FLA” or equivalent.
- e) “Install device in pollution degree 2 environment.” Or equivalent.
- f) “Suitable for use on a circuit capable of delivering not more than 5,000 rms symmetrical amperes, 480/240 volts maximum when protected by made by COOPER BUSSMANN LLC Class T Fuse.” Or equivalent. Recommended input fuse selection listed below:

Frame Size or Model	Fuse Model	Fuse Current Rating
10G-31-0015-XX 10G-31-0025-XX 10G-31-0035-XX 10G-31-0045-XX	JJS-15	15A
10G-32-0050-XX 10G-32-0070-XX 10G-32-0100-XX	JJS-25	25A
10G-11-0015-XX 10G-11-0025-XX 10G-11-0035-XX 10G-11-0045-XX	JJS-15	15A
10G-12-0050-XX 10G-12-0070-XX 10G-12-0010-XX	JJS-25	25A

14-6 Compliance

Frame Size or Model	Fuse Model	Fuse Current Rating
10G-41-0006-XX 10G-41-0010-XX 10G-41-0015-XX	JJS-6	6A
10G-42-0020-XX 10G-42-0030-XX 10G-42-0040-XX 10G-42-0065-XX	JJS-15	15A
10G-43-0080-XX 10G-43-0090-XX 10G-43-0120-XX	JJS-30	30A
10G-44-0170-XX	JJS-45	45A
10G-44-0230-XX	JJS-60	60A
10G-45-0320-XX	JJS-80	80A
10G-45-0380-XX	JJS-90	90A
10G-45-0440-XX	JJS-100	100A
10G-46-0600-XX	AJT-125	125A
10G-47-0750-XX	AJT-150	150A
10G-47-0900-XX	AJT-200	200A
10G-48-1100-XX	AJT-200	200A
10G-48-1500-XX	AJT-300	300A
10G-49-1800-XX	AJT-350	350A
10G-49-2200-XX	AJT-400	400A
10G-410-2650-XX	AJT-500	500A
10G-411-3200-XX	AJT-600	600A
10G-411-3600-XX	AJT-600	600A

- g) "Integral solid state short circuit protection does not provide branch circuit protection. Branch circuit protection must be provided in accordance with the National Electrical Code and any additional local codes" or equivalent.
- h) "CAUTION – Risk of Electric Shock" should be provided, followed by instructions to discharge the Bus Capacitor or indicating the time required (5 minutes) for Bus Capacitor to discharge to a level below 50Vdc.
- i) "Drives have no provision for motor over temperature protection" or equivalent.
- j) For use in Canada only: "TRANSIENT SURGE SUPPRESSION SHALL BE INSTALLED ON THE LINE SIDE OF THIS EQUIPMENT AND SHALL BE RATED ___480/240___ V (PHASE TO GROUND), 480/240V (PHASE TO PHASE), SUITABLE FOR OVERVOLTAGE CATEGORY _III_, AND SHALL PROVIDE PROTECTION FOR A RATED IMPULSE WITHSTAND VOLTAGE PEAK OF _ 6Kv" or equivalent.
- k) Field wiring terminal markings – Wiring terminals shall be marked to indicate the proper connections for power supply and load, or a wiring diagram coded to the terminal marking shall be securely attached to the device.
- l) "Use 60/75°C CU wire" or equivalent.

m) Required wire torque, type and range listed below:

Frame Size	Terminal Type	Required Torque (in-lbs)	Wire Range (AWG)	Wire Type
10G-31-0015-XX 10G-31-0025-XX 10G-31-0035-XX 10G-31-0045-XX	Input and Output Terminal Block	10	12	STR/SOL
10G-32-0050-XX 10G-32-0070-XX 10G-32-0100-XX	Input and Output Terminal Block	10	10	STR/SOL
10G-11-0015-XX 10G-11-0025-XX 10G-11-0035-XX 10G-11-0045-XX	Input and Output Terminal Block	10	14	STR/SOL
10G-12-0050-XX 10G-12-0070-XX 10G-12-0010-XX	Input and Output Terminal Block	10	14	STR/SOL
10G-41-0006-XX 10G-41-0010-XX 10G-41-0015-XX	Input and Output Terminal Block	6	14	STR/SOL
10G-42-0020-XX 10G-42-0030-XX 10G-42-0040-XX 10G-42-0065-XX	Input and Output Terminal Block	10	14	STR/SOL
10G-43-0080-XX 10G-43-0090-XX	Input and Output Terminal Block	10.5	14	STR/SOL
10G-43-0120-XX	Input and Output Terminal Block	10.5	10	STR/SOL
10G-44-0170-XX	Input and Output Terminal Block	19	10	STR/SOL
10G-44-0230-XX	Input and Output Terminal Block	30.4	8	STR/SOL
10G-45-0320-XX	Input and Output Terminal Block	30.4	6	STR/SOL
10G-45-0380-XX 10G-45-0440-XX	Input and Output Terminal Block	30.4	4	STR/SOL
10G-46-0600-XX	Input and Output Terminal Block	39.0	3	STR/SOL
10G-47-0750-XX	Input and Output Terminal Block	96.0	3	STR/SOL
10G-47-0900-XX	Input and Output Terminal Block	96.0	1	
10G-48-1100-XX	Input and Output Terminal	96.0	1/0	

14-8 Compliance

Frame Size	Terminal Type	Required Torque (in-lbs)	Wire Range (AWG)	Wire Type
	Block			
10G-48-1500-XX	Input and Output Terminal Block	96.0	3/0	
10G-49-1800-XX	Input and Output Terminal Block	189.0	250kcmil	STR/SOL
10G-49-2200-XX	Input and Output Terminal Block	189.0	300kcmil or 2x1/0	
10G-410-2650-XX	Input and Output Terminal Block	189.0	500kcmil or 2x2/0	
10G-411-3200-XX	Input and Output Terminal Block	330.0	600kcmil or 2x4/0	STR/SOL
10G-411-3600-XX	Input and Output Terminal Block	330.0	750kcmil or 2x4/0	

Grounding – The pressure wire connector intended for connection for field installed equipment, grounding conductor shall be plainly identified such as being marked “G”, “GRD”, “Ground”, “Grounding”, or equivalent or with the grounding symbol (IEC 417, Symbol 5019).

Tightening torque and wire range for field grounding wiring terminals are marked adjacent to the terminal or on the wiring diagram.

Frame Size	Terminal Type	Required Torque (in-lbs)	Wire Range (AWG)
10G-31-0015-XX 10G-31-0025-XX 10G-31-0035-XX 10G-31-0045-XX 10G-32-0050-XX 10G-32-0070-XX 10G-32-0100-XX 10G-11-0015-XX 10G-11-0025-XX 10G-11-0035-XX 10G-11-0045-XX 10G-12-0050-XX 10G-12-0070-XX 10G-12-0010-XX 10G-41-0006-XX 10G-41-0010-XX 10G-41-0015-XX 10G-42-0020-XX 10G-42-0030-XX 10G-42-0040-XX 10G-42-0065-XX 10G-43-0080-XX 10G-43-0090-XX 10G-43-0120-XX 10G-44-0170-XX 10G-44-0230-XX 10G-45-0320-XX 10G-45-0380-XX 10G-45-0440-XX	Grounding Terminal Block	6.2	8
10G-46-0600-XX		39.0	6
10G-47-0750-XX		96.0	6
10G-47-0900-XX		96.0	6
10G-48-1100-XX		96.0	6
10G-48-1500-XX		96.0	4
10G-49-1800-XX		189.0	3
10G-49-2200-XX		189.0	3
10G-410-2650-XX		96.0	2
10G-411-3200-XX		96.0	1
10G-411-3600-XX		96.0	1

DECLARATION OF CONFORMITY

AC10 SERIES VARIABLE SPEED DRIVES	
MANUFACTURERS EC DECLARATIONS OF CONFORMITY	
Date CE marked first applied: 01/12/13	
<p style="text-align: center;">EMC Directive In accordance with the EC Directive 2014/30/EU</p> <p>We Parker Hannifin Manufacturing Limited, address as below, declare under our sole responsibility that the above Electronic Products when installed and operated with reference to the instructions in the Product Manual (provided with each piece of equipment) is in accordance with the relevant clauses from the following standards:- EN 61800-3 (2004)(+A1:2012)</p> <p><i>Note: Filtered versions</i></p>	<p style="text-align: center;">Low Voltage Directive In accordance with the EC Directive 2014/35/EU</p> <p>We Parker Hannifin Manufacturing Limited, address as below, declare under our sole responsibility that the above Electronic Products when installed and operated with reference to the instructions in the Product Manual (provided with each piece of equipment), is in accordance with the following standard :- EN 61800-5-1 (2007)</p>
MANUFACTURERS DECLARATIONS OF CONFORMITY	
<p style="text-align: center;">EMC Declaration</p> <p>We Parker Hannifin Manufacturing Limited, address as below, declare under our sole responsibility that the above Electronic Products when installed and operated with reference to the instructions in the Product Manual (provided with each piece of equipment) is in accordance with the relevant clauses from the following standards:- BSEN61800-3 (2004)(+A1:2012)</p> <p>Notes: Non-filtered versions This is provided to aid justification for EMC Compliance when the unit is used as a component.</p>	<p style="text-align: center;">Low Voltage and Machinery Directives</p> <p>The above Electronic Products are components to be incorporated into machinery and may not be operated alone. The complete machinery or installation using this equipment may only be put into service when all safety considerations of the Directive 2006/42/EC are fully implemented. Particular reference should be made to EN60204-1 2006 (Safety of Machinery - Electrical Equipment of Machines). All instructions, warnings and safety information of the Product Manual must be implemented.</p>
 <p>Dr. Martin Payn (Drives Engineering & Global EM Compliance Manager)</p> <p>Parker Hannifin Manufacturing Limited, Automation Group, Electromechanical Drives Business Unit, NEW COURTWICK LANE, LITTLEHAMPTON, WEST SUSSEX BN17 7RZ TELEPHONE: +44 (0) 1903 737000, FAX: +44 (0)1903 737100 Registered Number 4806503 England. Registered Office: 55 Maylands Avenue, Hemel Hempstead, Herts HP2 4SJ</p>	

Chapter 15 Parameter Reference

Basic parameters: F100-F160

Function Code	Function Definition	Setting Range	Mfr's Value	Change
F100	User's Password	0~9999		√
F102	Inverter's Rated Current (A)		Subject to inverter model	○*
F103	Inverter Power (kW)		Subject to inverter model	○*
F104	Reserved			
F105	Software Edition No.		Subject to inverter model	△
F106	Control Mode	Setting range: 0: Sensorless vector control (SVC); 1: Reserved; 2: V/Hz 3: Vector control 1 6: PMSM sensorless vector control	2	×
F107	Password Protection	0: Disabled; 1: Enabled	0	√
F108	User's Password	0~9999	8	√
F109	Starting Frequency (Hz)	0.0~10.00Hz	0.0	√
F110	Holding Time of Starting Frequency (s)	0.0~999.9	0.0	√
F111	Max Frequency (Hz)	F113~590.0Hz	50.00	√
F112	Min Frequency (Hz)	0.00Hz~F113	0.50	√
F113	Target Frequency (Hz)	F112~F111	50.00	√
F114	1 st Acceleration Time (s)	0.1~3000	subject to inverter model	√
F115	1 st Deceleration Time (s)	0.1~3000		√
F116	2 nd Acceleration Time (s)	0.1~3000		√
F117	2 nd Deceleration Time (s)	0.1~3000		√
F118	Base Frequency (Hz)	15.00~590.0	50.00	×
F119	Setting Accel/Decel Reference Time	0: 0~50.00Hz 1: 0~ F111	0	×
F120	Forward/Reverse Switchover Dead-Time	0.0~3000	0.0	√
F121	Reserved			
F122	Reverse Running Forbidden	0: False; 1: True	0	×
F123	Minus Frequency is Valid in the Mode of Combined Speed Control.	0: False; 1: Trued	0	×
F124	Jogging Frequency	F112~F111	5.00Hz	√

15-2 Parameter Reference

Function Code	Function Definition	Setting Range	Mfr's Value	Change
F125	Jogging Acceleration Time	0.1~3000S	subject to inverter model	√
F126	Jogging Deceleration Time	0.1~3000S		√
F127	Skip Frequency A	0.00~590.0Hz	0.00	√
F128	Skip Width A	±2.50Hz	0.00	√
F129	Skip Frequency B	0.00~590.0Hz	0.00	√
F130	Skip Width B	±2.50Hz	0.00	√
F131	Running Display Items	0—Output frequency / function code 1—Output RPM 2—Output current 4—Output voltage 8—DC Bus Voltage 16—PID feedback value 32—Temperature 64—Reserved 128—Linear speed 256—PID given value 512—Reserved 1024—Reserved 2048—Output power 4096— Output torque	0+1+2+4+8=15	√
F132	Display Items for Stop Mode	0: frequency / function code 1: Keypad jogging 2: Target RPM 4: DC Bus Voltage 8: PID feedback value 16: Temperature 32: Reserved 64: PID given value 128: Reserved 256: Reserved 512: Setting torque	2+4=6	√
F133	Drive Ratio of Driven System	0.10~200.0	1.0	√
F134	Transmission-wheel Radius	0.001~1.000	0.001	√
F135	Reserved			
F136	Slip Compensation	0~10	0	×
F137	Torque Compensation Mode	0: Linear compensation; 1: Quadratic compensation; 2: User-defined multipoint compensation 3: Auto torque compensation	3	×

Function Code	Function Definition	Setting Range	Mfr's Value	Change
F138	Linear Compensation	1~20	subject to inverter model	X
F139	Square Compensation	1: 1.5 2: 1.8 3: 1.9 4: 2.0	1	X
F140	Voltage compensation point frequency (Hz)	0~F142	1.00	X
F141	Voltage compensation point 1 (%)	0~100%	4	X
F142	User-defined frequency point F2	F140~F144	5.00	X
F143	User-defined voltage point V2	0~100%	13	X
F144	User-defined frequency point F3	F142~F146	10.00	X
F145	User-defined voltage point V3	0~100%	24	X
F146	User-defined frequency point F4	F144~F148	20.00	X
F147	User-defined voltage point V4	0~100%	45	X
F148	User-defined frequency point F5	F146~F150	30.00	X
F149	User-defined voltage point V5	0~100%	63	X
F150	User-defined frequency point F6	F148~F118	40.00	X
F151	User-defined voltage point V6	0~100%	81	X
F152	Output voltage corresponding to turnover frequency	10~100%	100	X
F153	Carrier frequency setting	subject to inverter model	subject to inverter model	X
F154	Automatic voltage rectification	Setting range: 0: Disabled 1: Enabled 2: Disabled during deceleration process	0	X
F155	Digital secondary frequency setting (Hz)	0~F111	0.00	X
F156	Digital secondary frequency polarity setting	0~1	0	X
F157	Reading secondary frequency			Δ
F158	Reading secondary frequency polarity			Δ
F159	Random carrier-wave frequency selection	0: Control speed normally 1: Random carrier-wave frequency	1	
F160	Reverting to manufacturer values (Factory Defaults)	0: Not reverting to manufacturer values 1: Reverting to manufacturer values	0	X

15-4 Parameter Reference

Running control mode: F200-F230

Function Code	Function Definition	Setting Range	Mfr's Value	Change
F200	Source of start command	0: Keypad command 1: Terminal command 2: Keypad+Terminal 3:MODBUS 4: Keypad+Terminal+MODBUS	4	×
F201	Source of stop command	0: Keypad command 1: Terminal command 2: Keypad+Terminal 3:MODBUS 4: Keypad+Terminal+MODBUS	4	×
F202	Mode of direction setting	0: Forward running locking 1: Reverse running locking 2: Terminal setting 3: Keypad	0	×
F203	Main frequency source (X)	0: Digital setting memory 1: External analog AI1 2: External analog AI2 3: Reserved 4: Stage speed control 5: No memory by digital setting 6: Reserved 7: Reserved 8: Reserved 9: PID adjusting 10: MODBUS	0	×
F204	Secondary frequency source (Y)	0: Digital setting memory 1: External analog AI1 2: External analog AI2 3: Reserved 4: Stage speed control 5: PID adjusting 6: Reserved	0	×
F205	Reference for selecting secondary frequency source (Y) range	0: Relative to max frequency 1: Relative to main frequency (X)	0	×
F206	Secondary frequency (Y) range	0~100%	100	×
F207	Frequency source selecting	0: X 1: X+Y 2: X or Y (terminal switchover) 3: X or X+Y (terminal switchover) 4: Combination of stage speed and analog 5: X-Y 6: Reserved	0	×

Function Code	Function Definition	Setting Range	Mfr's Value	Change
F208	Terminal operation mode	0: No function 1: Two-line operation mode 1 2: Two-line operation mode 2 3: Three-line operation mode 1 4: Three-line operation mode 2 5: Start/stop controlled by direction pulse	0	×
F209	Motor stopping mode	0: stop by deceleration time 1: free stop (coast stop)	0	×
F210	Frequency display accuracy	0.01~2.00	0.01	√
F211	Speed of digital control	0.01~100.00Hz/S	5.00	√
F212	Direction memory	0: Disabled 1: Enabled	0	√
F213	Auto-starting after repowered on	0: Disabled 1: Enabled	0	√
F214	Auto-starting after reset	0: Disabled 1: Enabled	0	√
F215	Auto-starting delay time	0.1~3000.0	60.0	√
F216	Auto-start restart attempts	0~5	0	√
F217	Fault reset delay	0.0~10.0	3.0	√
F218	Reserved			
F219	Write EEPROM by Modbus	0: Disabled 1: Enabled	1	√
F220	Frequency memory after power-down	0: Disabled 1: Enabled	0	√
F221- F223	Reserved			
F224	When target frequency is lower than Min frequency	0: Stop 1: run at min frequency	1	√
F225- F227	Reserved			
F228	Application selection	0: None 1: Basic speed control 2: Auto/manual control 3: Stage speed control 4: Terminal control 5: PID control	0 No Macro selected	
F229~ F230	Reserved			

15-6 Parameter Reference

Multifunctional Input and Output Terminals: F300-F330

Function Code	Function Definition	Setting Range	Mfr's Value	Change
F300	Relay token output	0: No function 1: Inverter fault 2: At target frequency 1 3: At target frequency 2	1	√
F301	DO1 token output	4: Free stop (coast stop) 5: In running status 1 6: DC braking	14	√
F302	DO2 token output	7: Accel/decel time switchover 8-9: Reserved 10: Inverter overload pre-alarm 11: Motor overload pre-alarm 12: Stalling 13: Inverter is ready to run 14: In running status 2 15: At speed 16: Overheat pre-alarm 17: Over target output current 18: Analog input disconnection 19: Reserved 20: At Zero output current 21: DO1 controlled by PC/PLC 22: Reserved 23: TA, TC fault relay output controlled by PC/PLC 24: Watchdog 25-39: Reserved 40: High-frequency performance switchover	5	
F303- F306	Reserved			
F307	Target frequency 1	F112~F111	10.00	√
F308	Target frequency 2	F112~F111	50.00	√
F309	Target frequency width (%)	0~100	50	√
F310	Target current (A)	0~1000	Rated current	√
F311	Target current width (%)	0~100	10	√
F312	At speed threshold (Hz)	0.00~5.00	0.00	√
F313- F315	Reserved			

Function Code	Function Definition	Setting Range	Mfr's Value	Change
F316	DI1 terminal function setting	0: No function	11	√
F317	DI2 terminal function setting	1: Run	9	√
F318	DI3 terminal function setting	2: Stop	15	√
F319	DI4 terminal function setting	3: Multi-stage speed 1	16	√
F320	DI5 terminal function setting	4: Multi-stage speed 2	7	
F321	DI6 terminal function setting	5: Multi-stage speed 3	8	
F322	DI7 terminal function setting	6: Multi-stage speed 4	0	
F323	DI8 terminal function setting	7: Reset	0	√
		8: Free stop (coast stop)		
		9: External coast stop		
		10: Acceleration/deceleration hold		
		11: Forward run jogging		
		12: Reverse run jogging		
		13: Increase frequency UP		
		14: Decrease frequency DOWN		
		15: "FWD" terminal		
		16: "REV" terminal		
		17: Three-line type input "X" terminal		
		18: Accel/decel time switchover 1		
		19: Reserved		
		20: Reserved		
		21: Frequency source switchover		
		22: Fire control switchover		
		23: Emergency fire control		
		24: Accel / decel switchover 2		
		25: Normally-open PTC motor temperature protection		
		26: Normally-closed PTC motor temperature protection		
		27: High-frequency switchover		
		28: Jogging (no direction)		
		29: Watchdog		
		30: Frequency reset		
		31: Manual / auto switchover		
		32: Manual running		
		33: Auto running		
		34: Direction		
F324	Free stop terminal logic	0: positive logic (valid for low level);	0	×
F325	External coast stop terminal logic	1: negative logic (valid for high level)	0	×
F326	Watchdog time	0.0~3000.0	10.0	√
F327	Stop mode	0: Free stop	0	×
		1: Deceleration to stop		
F328	Terminal filter times	1~100	10	√
F329	Reserved			
F330	Diagnostics of DIX terminal			△
F331	Monitoring AI1			△
F332	Monitoring AI2			△
F335	Relay output simulation	Setting range:	0	×
F336	DO1 output simulation	0: Output true	0	×
		1: Output false		
F338	AO1 output simulation	Setting range: 0~4095	0	×

15-8 Parameter Reference

Function Code	Function Definition	Setting Range	Mfr's Value	Change
F340	Selection of terminal negative logic	0: None 1: DI1 negative logic 2: DI2 negative logic 4: DI3 negative logic 8: DI4 negative logic 16: DI5 negative logic 32: DI6 negative logic 64: DI7 negative logic 128: DI8 negative logic	0	√

Analog Input and Output: F400-F480

Function Code	Function Definition	Setting Range	Mfr's Value	Change
F400	Lower limit of AI1 channel input	0.00~F402	0.01	√
F401	Corresponding setting for lower limit of AI1 input	0~F403	1.00	√
F402	Upper limit of AI1 channel input	F400~10.00	10.00	√
F403	Corresponding setting for upper limit of AI1 input	Max (1.00, F401) ~2.00	2.00	√
F404	AI1 channel proportional gain K1	0.0~10.0	1.0	√
F405	AI1 filtering time constant	0.01~10.0	0.10	√
F406	Lower limit of AI2 channel input	0.00~F408	0.01V	√
F407	Corresponding setting for lower limit of AI2 input	0~F409	1.00	√
F408	Upper limit of AI2 channel input	F406~10.00	10.00V	√
F409	Corresponding setting for upper limit of AI2 input	Max (1.00, F407) ~2.00	2.00	√
F410	AI2 channel proportional gain K2	0.0~10.0	1.0	√
F411	AI2 filtering time constant	0.01~10.0	0.10	√
F418	AI1 channel 0Hz voltage dead zone	0~0.50V (Positive-Negative)	0.00	√
F419	AI2 channel 0Hz voltage dead zone	0~0.50V (Positive-Negative)	0.00	√
F421	Panel selection	0: Local keypad panel 1: Remote control keypad panel 2: Local keypad + remote control keypad	1	√
F422	Reserved			
F423	AO1 output range	0: 0~5V; 1: 0~10V or 0-20mA 2: 4-20mA	1	√
F424	AO1 lowest corresponding frequency	0.0~F425	0.05Hz	√
F425	AO1 highest corresponding frequency	F424~F111	50.00Hz	√
F426	AO1 output compensation	0~120	100	√
F427	AO2 output compensation	0: 0~20mA 1: 4~20mA	0	√
F428	AO2 lowest corresponding frequency (Hz)	0.0~F429	0.05	√
F429	AO2 highest corresponding frequency (Hz)	F428~F111	50.00	√
F430	AO2 output compensation (%)	0~120	100	√

15-10 Parameter Reference

Function Code	Function Definition	Setting Range	Mfr's Value	Change
F431	AO1 analog output signal selecting	0: Running frequency; 1: Output current; 2: Output voltage;	0	√
F432	AO2 analog output signal selecting	3: Analog AI1; 4: Analog AI2; 6: Output torque; 7: Given by PC/PLC; 8: Target frequency	1	√
F433	Corresponding current for full range of external voltmeter	0.01~5.00 times of rated current	2	×
F434	Corresponding current for full range of external ammeter		2	×
F435- F436	Reserved			
F437	Analog filter width	1~100	10	*
F438- F459	Reserved			
F460	AI1channel input mode	0: Straight line mode 1: Folding line mode	0	×
F461	AI2 channel input mode	0: Straight line mode 1: Folding line mode	0	×
F462	AI1 insertion point A1 voltage value	F400~F464	2.00V	×
F463	AI1 insertion point A1 setting value	F401~F465	1.20	×
F464	AI1 insertion point A2 voltage value	F462~F466	5.00V	×
F465	AI1 insertion point A2 setting value	F463~F467	1.50	×
F466	AI1 insertion point A3 voltage value	F464~F402	8.00V	×
F467	AI1 insertion point A3 setting value	F465~F403	1.80	×
F468	AI2 insertion point B1 voltage value	F406~F470	2.00V	×
F469	AI2 insertion point B1 setting value	F407~F471	1.20	×
F470	AI2 insertion point B2 voltage value	F468~F472	5.00V	×
F471	AI2 insertion point B2 setting value	F469~F473	1.50	×
F472	AI2 insertion point B3 voltage value	F470~F412	8.00V	×
F473	AI2 insertion point B3 setting value	F471~F413	1.80	×

Multi-stage Speed Control: F500-F580

Function Code	Function Definition	Setting Range	Mfr's Value	Change
F500	Stage speed type	0: 3-stage speed; 1: 15-stage speed; 2: Max 8-stage speed auto circulating	1	×
F501	Selection of Stage Speed Under Auto-circulation Speed Control	2~8	7	√
F502	Selection of Times of Auto- Circulation Speed Control	0~9999 (when the value is set to 0, the inverter will carry out infinite circulating)	0	√
F503	Status after auto circulation running Finished	0: Stop 1: Keep running at last stage speed	0	√
F504	Frequency setting for stage 1 speed	F112~F111	5.00Hz	√
F505	Frequency setting for stage 2 speed	F112~F111	10.00Hz	√
F506	Frequency setting for stage 3 speed	F112~F111	15.00Hz	√
F507	Frequency setting for stage 4 speed	F112~F111	20.00Hz	√
F508	Frequency setting for stage 5 speed	F112~F111	25.00Hz	√
F509	Frequency setting for stage 6 speed	F112~F111	30.00Hz	√
F510	Frequency setting for stage 7 speed	F112~F111	35.00Hz	√
F511	Frequency setting for stage 8 speed	F112~F111	40.00Hz	√
F512	Frequency setting for stage 9 speed	F112~F111	5.00Hz	√
F513	Frequency setting for stage 10 speed	F112~F111	10.00Hz	√
F514	Frequency setting for stage 11 speed	F112~F111	15.00Hz	√
F515	Frequency setting for stage 12 speed	F112~F111	20.00Hz	√
F516	Frequency setting for stage 13 speed	F112~F111	25.00Hz	√
F517	Frequency setting for stage 14 speed	F112~F111	30.00Hz	√
F518	Frequency setting for stage 15 speed	F112~F111	35.00Hz	√
F519- F533	Acceleration time setting for the speeds from Stage 1 to stage 15	0.1~3000S	Subject to inverter model	√
F534- F548	Deceleration time setting for the speeds from Stage 1 to stage 15	0.1~3000S		√
F549- F556	Running directions of stage speeds from Stage 1 to stage 8	0: Forward running; 1: Reverse running	0	√
F557- F564	Running time of stage speeds from Stage 1 to stage 8	0.1~3000S	1.0S	√
F565- F572	Stop time after finishing stages from Stage 1 to stage 8.	0.0~3000S	0.0S	√
F573- F579	Running directions of stage speeds from Stage 9 to stage 15.	0: Forward running; 1: Reverse running	0	√
F580	Reserved			

15-12 Parameter Reference

Auxiliary Functions: F600-F670

Function Code	Function Definition	Setting Range	Mfr's Value	Change
F600	DC Braking Function Selection	0: Disabled 1: Braking before starting 2: Braking during stopping 3: Braking during starting and stopping	0	×
F601	Initial Frequency for DC Braking	0.20~50.00	1.00	√
F602	DC Braking level before Starting (V/A)	0~100	10	√
F603	DC Braking level During Stop (V/A)	0~100	10	√
F604	Braking Lasting Time Before Starting	0.00~30.00	0.50	√
F605	Braking Lasting Time During Stopping	0.00~30.00	0.50	√
F606	Reserved			
F607	Stall Adjustment Function	0: Disabled 1: Enabled 2: Reserved 3: Voltage current control 4: Voltage control 5: Current control	0	√
F608	Stall Current Level (%)	60~200	160	√
F609	Stall Voltage Level (%)	110~200	1 phase: 130 3 phase: 140	√
F610	Stall Time Protection	0.1~3000	60.0	√
F611	Dynamic Braking Threshold (V)	200~1000	Subject to inverter model	△
F612	Dynamic Braking Duty Ratio (%)	0~100%	80	×
F613	Flycatching	0: Invalid 1: Valid 2: Valid at the first time	0	×
F614	Flycatching Rate Mode	0: Flycatching from frequency memory 1: Flycatching from max frequency 2: Flycatching from frequency memory and direction memory 3: Flycatching from max frequency and direction memory	0	×
F615	Flycatching Rate	1~100	20	×
F616-F618	Reserved			
F619	Flycatching (fault) Time out (S)	0~3000	60	
F620 – F621	Reserved			
F622	Dynamic Braking Mode	0: Fixed duty ratio 1: Auto duty ratio	0	√

Function Code	Function Definition	Setting Range	Mfr's Value	Change
F627	Current Limiting when Flycatching	50-200	100	×
F631	VDC Adjustment Selection	0: Disabled 1: Enabled	0	√
F632	Target voltage of VDC adjustor (V)	200-800	Subject to inverter model	√○
F633- F637	Reserved			
F638	Parameters copy enabled	0: Copy forbidden 1: Parameters copy 1 (voltage level and power rating are totally same) 2: Parameters copy 2 (without considering voltage level and power rating)	1	√
F639	Reserved			
F640	Parameter copy type	0: Copy all parameters 1: Copy parameters (except motor parameters from F801 to F810/F844)	1	√
F641- F649	Reserved			
F650	High-frequency performance	Setting range: 0: Invalid 1: Terminal enabled 2: Enabled mode 1 3: Enabled mode 2	2	×○
F651	Switchover frequency 1	F652-150.00	100.00	√○
F652	Switchover frequency 2	0-F651	95.00	√○
F653- F670	Reserved			

Timing Control and Protection: F700-F770

Function Code	Function Definition	Setting Range	Mfr's Value	Change
F700	Selection of terminal free stop mode	0: Immediate free stop (coast stop) 1: Delayed free stop (coast stop)	0	√
F701	Delay time for free stop and programmable terminal action	0.0~60.0s	0.0	√
F702	Fan control mode	0: Controlled by temperature 1: Running when inverter is powered on 2: Controlled by running status	2	√
F703	Reserved			
F704	Inverter Overload pre-alarm Setpoint (%)	50~100	80	×
F705	Motor Overload pre-alarm Setpoint (%)	50~100	80	×

15-14 Parameter Reference

Function Code	Function Definition	Setting Range	Mfr's Value	Change
F706	Inverter Overloading coefficient%	120~190	150	×
F707	Motor Overloading coefficient %	20~100	100	×
F708	Trip 1 Type (Newest)	Setting range: 2: Over current (OC) 3: Over voltage (OE) 4: Input phase loss (PF1) 5: Inverter overload (OL1) 6: Under voltage (LU) 7: Overheat (OH) 8: Motor overload (OL2) 11: External malfunction (ESP) 12: Current fault before running (Err3) 13. Studying parameters without motor (Err2) 15: Current sampling fault (Err4) 16: Over current 1 (OC1) 17: Output phase loss (PF0) 18: Aerr analog disconnected 23: Err5 PID parameters are set wrong 45: Communication Timeout (CE) 46: Flycatching fault (FL) 49: Watchdog fault (Err6) 67: Overcurrent (OC2)		△
F709	Trip 2 Type			△
F710	Trip 3 Type			△
F711	Trip 1 Fault Frequency			△
F712	Trip 1 Fault Current			△
F713	Trip 1 Fault DC Bus Voltage			△
F714	Trip 2 Fault Frequency			△
F715	Trip 2 Fault Current			△
F716	Trip 2 Fault DC Bus Voltage			△
F717	Trip 3 Fault Frequency			△
F718	Trip 3 Fault Current			△
F719	Trip 3 Fault DC Bus Voltage			△
F720	Number of Overcurrent Faults			△
F721	Number of Overvoltage Protection Faults			△
F722	Number of Overload Protection Fault			△
F723	Number of Overload Protection Fault			△
F724	Input Phase Loss	0: Disabled 1: Enabled	1	○×
F725	Reserved			
F726	Overheat	0: Disabled 1: Enabled	1	○×
F727	Output Phase Loss	0: Disabled 1: Enabled	0	○
F728	Input Phase Loss Filtering Constant	0.1~60.0	0.5	√
F730	Overheat Protection Filtering Constant	0.1~60.0	5.0	√

Function Code	Function Definition	Setting Range	Mfr's Value	Change
F732	Voltage Threshold of Under-voltage Protection	0~450	Subject to inverter model	○
F737	Over-current 1 Protection	0: Disabled 1: Enabled	0	
F738	Over-current 1 Protection Coefficient	0.50~3.00	2.50	
F739	Over-current 1 Protection Record			△
F740	Reserved			
F741	Analog Disconnected Protection	0: Disabled 1: Stop and AErr displays. 2: Stop and AErr is not displayed. 3: Inverter runs at the min frequency. 4: Reserved.	0	√
F742	Threshold of Analog Disconnected Protection (%)	1~100	50	○
F745	Threshold of Pre-alarm Overheat (%)	0~100	80	○*
F747	Carrier Frequency Auto-adjusting	0: Disabled 1: Enabled	1	√
F754	Zero-current Threshold (%)	0~200	5	×
F755	Duration time of zero-current	0~60	0.5	√

Motor parameters: F800-F830

Function Code	Function Definition	Setting Range	Mfr's Value	Change
F800	Motor's Parameters Selection	Setting range: 0: Disabled; 1: Rotating tuning.; 2: Stationary tuning	0	×
F801	Rated Power	0.2~1000kW		○×
F802	Rated Voltage	1~440V		○×
F803	Rated Current	0.1~6500A		○×
F804	Number of Motor Poles	2~100	4	○△
F805	Rated Rotary Speed	1~30000		○×
F806	Stator Resistance Ω	0.001~65.53Ω (22kW and below) 0.1~6553mΩ (above 22kW)	Subject to inverter model	○×
F807	Rotor Resistance Ω	0.001~65.53 Ω (22kW and below) 0.1~6553mΩ (above 22kW)	Subject to inverter model	○×
F808	Leakage Inductance(mH)	0.01~655.3mH (22kW and below) 0.001~65.53mH (above 22kW)	Subject to inverter model	○×

15-16 Parameter Reference

Function Code	Function Definition	Setting Range	Mfr's Value	Change
F809	Mutual Inductance(mH)	0.01~655.3mH (22kW and below) 0.001~65.53mH (above 22kW)	Subject to inverter model	○×
F810	Motor Rated Frequency	1.00~590Hz	50.00	○×
F812	Pre-exciting Time	0.000~30.00S	0.30	√
F813	Rotary Speed Loop KP1	0.01~20.00 (22kW and below) 1~100 (above 22kW)	Subject to inverter model	○√
F814	Rotary Speed Loop KI1	0.01~2.00 (22kW and below) 0.01~10.00 (above 22kW)	Subject to inverter model	○√
F815	Rotary Speed Loop KP2	0.01~20.00 (22kW and below) 1~100 (above 22kW)	Subject to inverter model	○√
F816	Rotary Speed Loop KI2	0.01~2.00 (22kW and below) 0.01~10.00 (above 22kW)	Subject to inverter model	○√
F817	PID Switching Frequency 1	0~F111	5.00	√
F818	PID Switching Frequency 2	F817~F111	50.00	√
F819~ F860	Reserved		Subject to inverter model	√
F870	PMSM back electromotive force (mV/rpm)	0.1~999.9	Subject to inverter model	○
F871	PMSM D-axis inductance (mH)	0.01~655.35	Subject to inverter model	○
F872	PMSM Q-axis inductance (mH)	0.01~655.35	Subject to inverter model	○
F873	PMSM stator resistance (Ω)	0.001~65.535	Subject to inverter model	○
F876	PMSM injection current without load (%)	0.0~100.0	20.0	×
F877	PMSM injection current compensation without load (%)	0.0~50.0	0.0	×
F878	PMSM cut-off point of injection current compensation without load (%)	0.0~50.0	10.0	×

Communication parameter: F900-F930

Function Code	Function Definition	Setting Range	Mfr's Value	Change
F900	Communication Address	1~255: single inverter address 0: broadcast address	1	√
F901	Communication Mode	1: ASCII 2: RTU	1	○√
F902	Stop Bits	1~2	2	√

Function Code	Function Definition	Setting Range	Mfr's Value	Change
F903	Parity Check	0: None 1: Odd 2: Even	0	√
F904	Baud Rate	0: 1200 1: 2400 2: 4800 3: 9600 4: 19200 5: 38400 6: 57600	3	√
F905	Communication Timeout	0.0~3000.0	0.0	√
F906- F930	Reserved			

PID parameters: FA00-FA80

Function Code	Function Definition	Setting Range	Mfr's Value	Change
FA01	PID reference signal source	0: FA04 1: AI1 2: AI2	0	×
FA02	PID feedback signal source	1: AI1 2: AI2	0	√
FA03	Max limit of PID adjusting (%)	FA04~100.0	10.0	√
FA04	Digital setting value of PID adjusting (%)	FA05~FA03	50.0	√
FA05	Min limit of PID adjusting (%)	0.0~FA04	0.0	√
FA06	PID polarity	0: Positive feedback 1: Negative feedback	1	×
FA07	Sleep function selection	0: Valid 1: Invalid	0	×
FA09	Min frequency of PID adjusting (Hz)	Max(F112, 0.1)~F111	5.00	√
FA10	Sleep delay time (s)	0~500.0	15.0	√
FA11	Wake delay time (s)	0.0~3000	3.0	√
FA12	Maximum output frequency of PID loop	FA09 – F111	50.00	√
FA18	Whether PID target is changed	0: Disabled 1: Enabled	1	×
FA19	Proportion Gain P	0.00~10.00	0.3	√
FA20	Integration time I (s)	0.0~100.0S	0.3	√
FA21	Differential time D (s)	0.00~10.00	0.0	√
FA22	PID sampling period (s)	0.1~10.0s	0.1	√
FA29	PID dead time (%)	0.0~10.0	2.0	√
FA58	Fire pressure given value (%)	0.0~100.0	80.0	√

15-18 Parameter Reference

Function Code	Function Definition	Setting Range	Mfr's Value	Change
FA59	Emergency fire mode	0: Disabled 1: Emergency fire mode 1 2: Emergency fire mode 2	0	√
FA60	Running frequency of emergency fire	F112~F111	50.0	√
FA61	Reserved			
FA62	When emergency fire control terminal is false	0: Inverter cannot be stopped manually 1: Inverter can be stopped manually	0	×
FA63-FA80	Reserved			

Torque control parameters: FC00-FC40

Function Code	Function Definition	Setting Range	Mfr's Value	Change
FC00	Speed/torque control selection	0: Speed control 1: Torque control 2: Terminal switchover	0	√
FC01	Delay time of torque/speed control switchover (S)	0.0~1.0	0.1	×
FC02	Torque accel/decel time (s)	0.1~100.0	1.0	√
FC03-FC05	Reserved			
FC06	Torque reference source	0: Digital given (FC09) 1: Analog input AI1 2: Analog input AI2	0	×
FC07	Torque reference coefficient	0~3.000	3.000	×
FC08	Reserved			
FC09	Torque reference command value (%)	0~300.0	100.0	√
FC10-FC13	Reserved			
FC14	Offset torque reference source	0: Digital given (FC17) 1: Analog input AI1 2: Analog input AI2	0	×
FC15	Offset torque coefficient	0~0.500	0.500	×
FC16	Offset torque cut-off frequency (%)	0~100.0	10.0	×
FC17	Offset torque command value (%)	0~50.0	10.0	√
FC18-FC21	Reserved			
FC22	Forward speed limit source	0: Digital given (FC23) 1: Analog input AI1 2: Analog input AI	0	×
FC23	Forward speed limit (%)	0~100.0	10.0	√
FC24	Reverse speed limit source	0: Digital given (FC25) 1: Analog input AI1	0	×

Function Code	Function Definition	Setting Range	Mfr's Value	Change
		2: Analog input AI		
FC25	Reverse speed limit (%)	0~100.0	10.0	√
FC26- FC27	Reserved			
FC28	Driving torque limit source	0: Digital given (FC30) 1: Analog input AI1 2: Analog input AI2	0	×
FC29	Driving torque limit coefficient	0~3.000	3.000	×
FC30	Driving torque limit (%)	0~300.0	200.0	√
FC31	Reserved			
FC32	Reserved			
FC33	Re-generating torque limit source	0: Digital given (FC35) 1: Analog input AI1 2: Analog input AI2	0	×
FC34	Re-generating torque limit coefficient	0~3.000	3.000	
FC35	Re-generating torque limit (%)	0~300.0	200.0	√
FC36- FC40	Reserved			

Note:

× indicating that function code can only be modified in stop state.

√ indicating that function code can be modified both in stop and run state.

△ indicating that function code can only be checked in stop or run state but cannot be modified.

○ indicating that function code cannot be initialized as inverter restores manufacturer's value but can only be modified manually.

Parker Worldwide

AE – UAE, Dubai
Tel: +971 4 8127100
parker.me@parker.com

AR – Argentina, Buenos Aires
Tel: +54 3327 44 4129

AT – Austria, Wiener Neustadt
Tel: +43 (0)2622 23501-0
parker.austria@parker.com

AT – Eastern Europe, Wiener Neustadt
Tel: +43 (0)2622 23501 900
parker.easteurope@parker.com

AU – Australia, Castle Hill
Tel: +61 (0)2-9634 7777

AZ – Azerbaijan, Baku
Tel: +994 50 2233 458
parker.azerbaijan@parker.com

BE/LU – Belgium, Nivelles
Tel: +32 (0)67 280 900
parker.belgium@parker.com

BR – Brazil, Cachoeirinha RS
Tel: +55 51 3470 9144

BY – Belarus, Minsk
Tel: +375 17 209 9399
parker.belarus@parker.com

CA – Canada, Milton, Ontario
Tel: +1 905 693 3000

CH – Switzerland, Etoy
Tel: +41 (0)21 821 87 00
parker.switzerland@parker.com

CL – Chile, Santiago
Tel: +56 2 623 1216

CN – China, Shanghai
Tel: +86 21 2899 5000

CZ – Czech Republic, Klecany
Tel: +420 284 083 111
parker.czechrepublic@parker.com

DE – Germany, Kaarst
Tel: +49 (0)2131 4016 0
parker.germany@parker.com

DK – Denmark, Ballerup
Tel: +45 43 56 04 00
parker.denmark@parker.com

ES – Spain, Madrid
Tel: +34 902 330 001
parker.spain@parker.com

FI – Finland, Vantaa
Tel: +358 (0)20 753 2500
parker.finland@parker.com

FR – France, Contamine s/Arve
Tel: +33 (0)4 50 25 80 25
parker.france@parker.com

GR – Greece, Athens
Tel: +30 210 933 6450
parker.greece@parker.com

HK – Hong Kong
Tel: +852 2428 8008

HU – Hungary, Budapest
Tel: +36 1 220 4155
parker.hungary@parker.com

IE – Ireland, Dublin
Tel: +353 (0)1 466 6370
parker.ireland@parker.com

IN – India, Mumbai
Tel: +91 22 6513 7081-85

IT – Italy, Corsico (MI)
Tel: +39 02 45 19 21
parker.italy@parker.com

JP – Japan, Tokyo
Tel: +81 (0)3 6408 3901

KR – South Korea, Seoul
Tel: +82 2 559 0400

KZ – Kazakhstan, Almaty
Tel: +7 7272 505 800
parker.easteurope@parker.com

MX – Mexico, Apodaca
Tel: +52 81 8156 6000

MY – Malaysia, Shah Alam
Tel: +60 3 7849 0800

NL – The Netherlands, Oldenzaal
Tel: +31 (0)541 585 000
parker.nl@parker.com

NO – Norway, Asker
Tel: +47 66 75 34 00
parker.norway@parker.com

NZ – New Zealand, Mt Wellington
Tel: +64 9 574 1744

PL – Poland, Warsaw
Tel: +48 (0)22 573 24 00
parker.poland@parker.com

PT – Portugal, Leca da Palmeira
Tel: +351 22 999 7360
parker.portugal@parker.com

RO – Romania, Bucharest
Tel: +40 21 252 1382
parker.romania@parker.com

RU – Russia, Moscow
Tel: +7 495 645-2156
parker.russia@parker.com

SE – Sweden, Spånga
Tel: +46 (0)8 59 79 50 00
parker.sweden@parker.com

SG – Singapore
Tel: +65 6887 6300

SK – Slovakia, Banská Bystrica
Tel: +421 484 162 252
parker.slovakia@parker.com

SL – Slovenia, Novo Mesto
Tel: +386 7 337 6650
parker.slovenia@parker.com

TH – Thailand, Bangkok
Tel: +662 717 8140

TR – Turkey, Istanbul
Tel: +90 216 4997081
parker.turkey@parker.com

TW – Taiwan, Taipei
Tel: +886 2 2298 8987

UA – Ukraine, Kiev
Tel: +380 44 494 2731
parker.ukraine@parker.com

UK – United Kingdom, Warwick
Tel: +44 (0)1926 317 878
parker.uk@parker.com

US – USA, Cleveland
Tel: +1 216 896 3000

VE – Venezuela, Caracas
Tel: +58 212 238 5422

ZA – South Africa, Kempton Park
Tel: +27 (0)11 961 0700
parker.southafrica@parker.com

European Product Information Centre
Free phone: 00 800 27 27 5374
(from AT, BE, CH, CZ, DE, EE, ES, FI, FR, IE, IL, IS, IT, LU, MT, NL, NO, PT, SE, SK, UK)

© 2012 Parker Hannifin Corporation. All rights reserved.



Parker Hannifin Manufacturing Limited
Automation Group, SSD Drives Europe,
New Courtwick Lane
Littlehampton, West Sussex BN17 7RZ
United Kingdom
Tel.: +44 (0) 1903 737000
Fax: +44 (0) 1903 737100
www.parker.com/ssd



* H A 5 0 2 3 2 0 U 0 0 1 0 6 *