

Configuration for version 5.x 690+

DWN			SIZE A	DWG. NO.	RFA
CHK		/1/T690v5_1.690.010	ISSUE		25 Jan 24
APP			SCALE	SHEET	1 OF 8
EDIT	LOC				

Sequencing and Reference

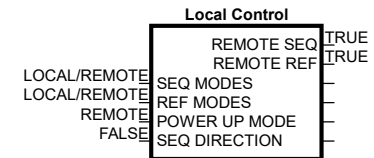
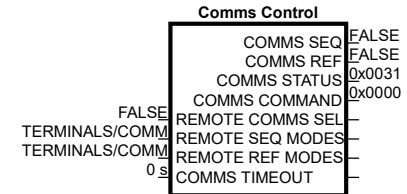
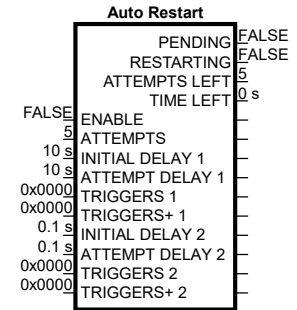

Communications

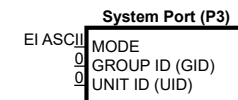
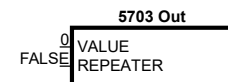
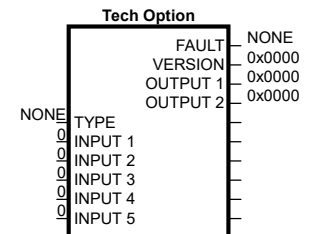
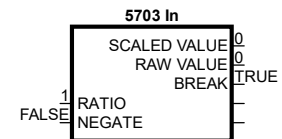

Configuration for version 5.x 690+

DWN			SIZE A	DWG. NO.	RFA
CHK		/1/T690v5_1.690.010	ISSUE		25 Jan 24
APP			SCALE	SHEET	2 OF 8
EDIT	LOC				

Motor Control

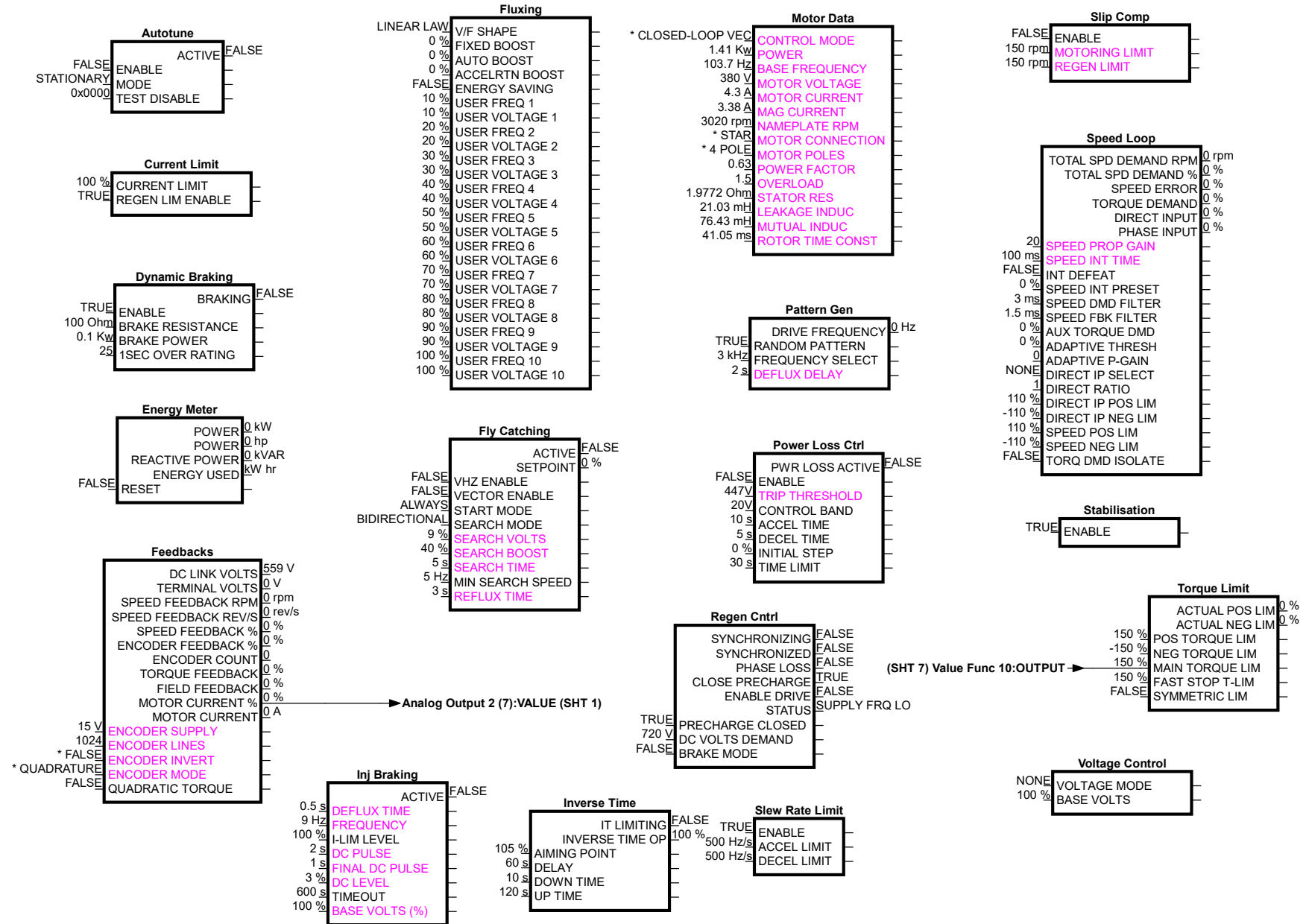

Configuration for version 5.x 690+

DWN			SIZE A	DWG. NO.	RFA
CHK		/1/T690v5_1.690.010	ISSUE		25 Jan 24
APP			SCALE	SHEET	3 OF 8
EDIT	LOC				

Setpoint Functions

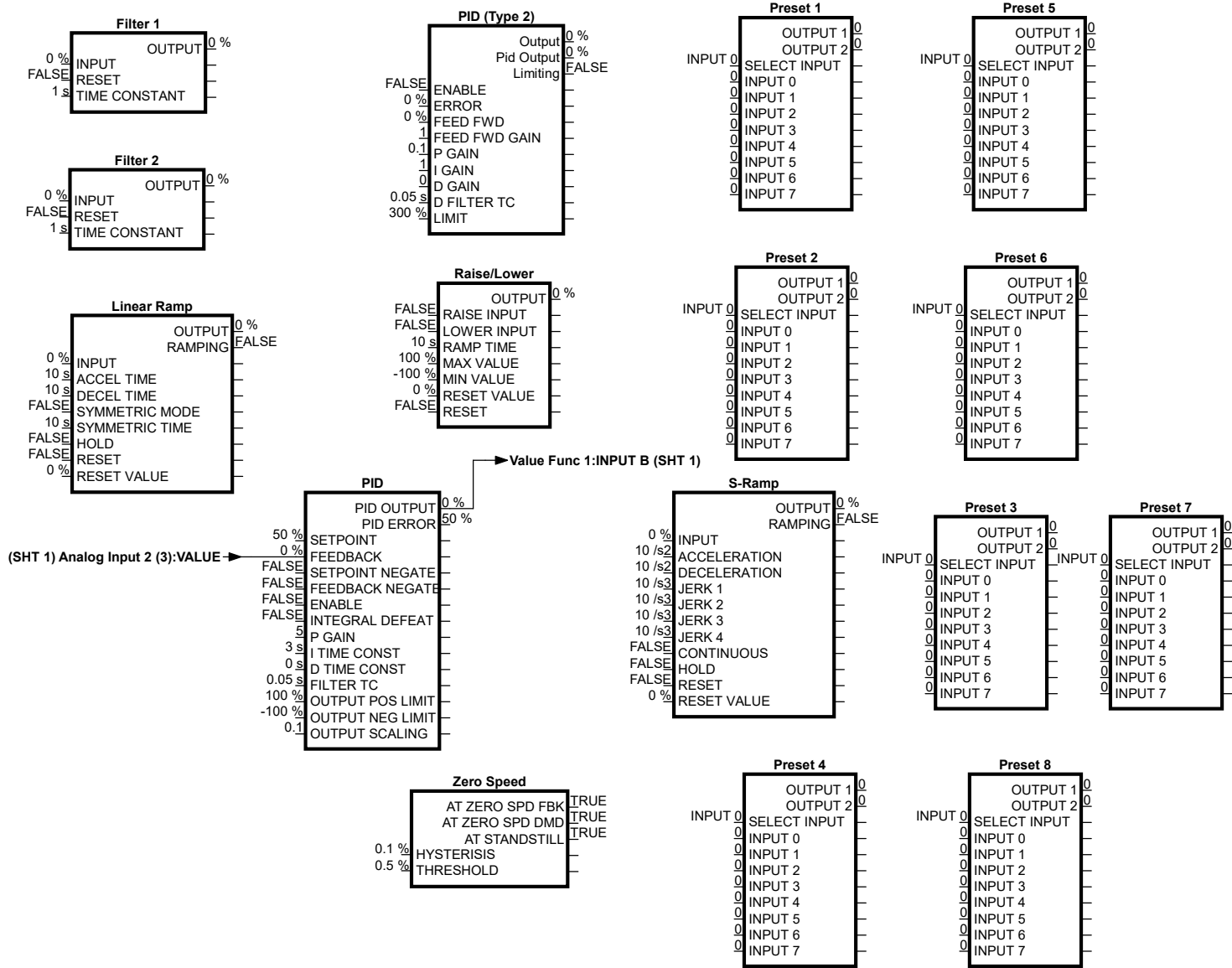

Trips

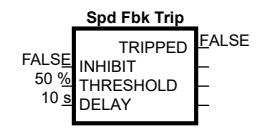
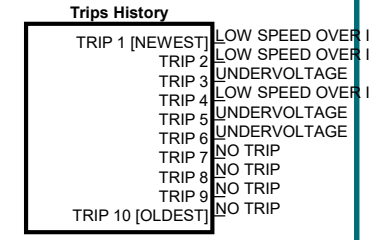

Hoist/Lift

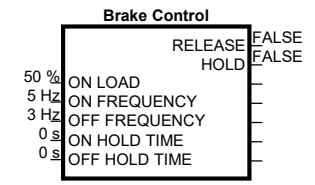

Configuration for version 5.x 690+

DWN			SIZE A	DWG. NO.	RFA
CHK		/1/T690v5_1.690.010	ISSUE		25 Jan 24
APP			SCALE	SHEET	4 OF 8
EDIT	LOC				

Winder

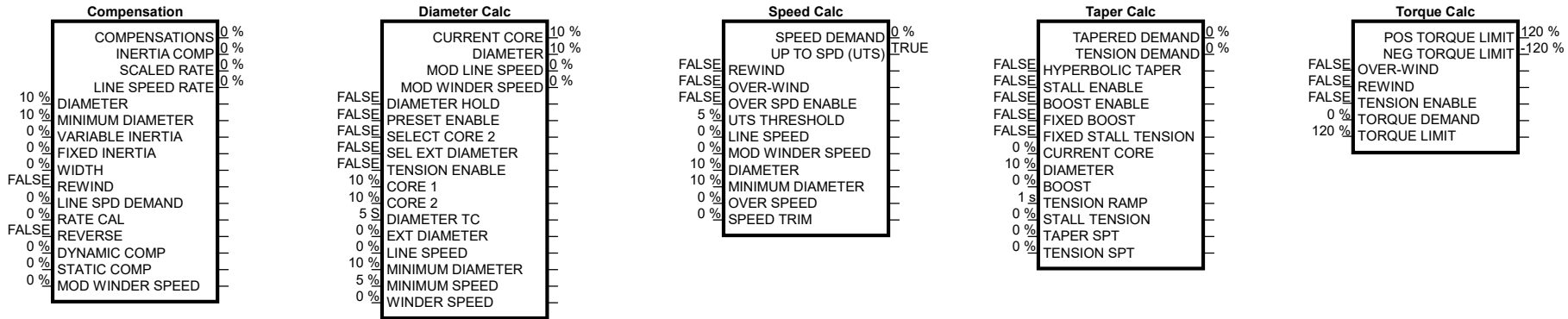

Inputs_Outputs

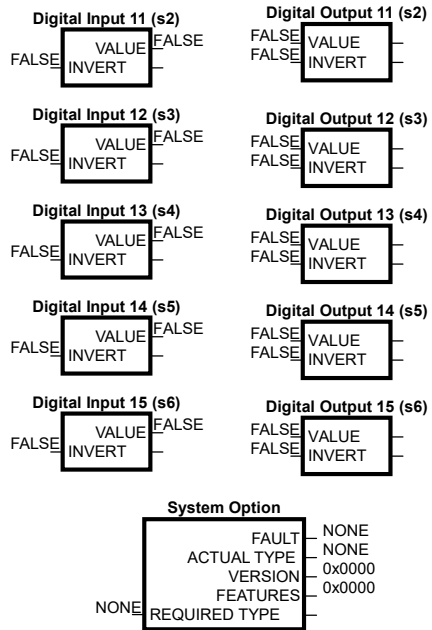

Configuration for version 5.x 690+

System Board

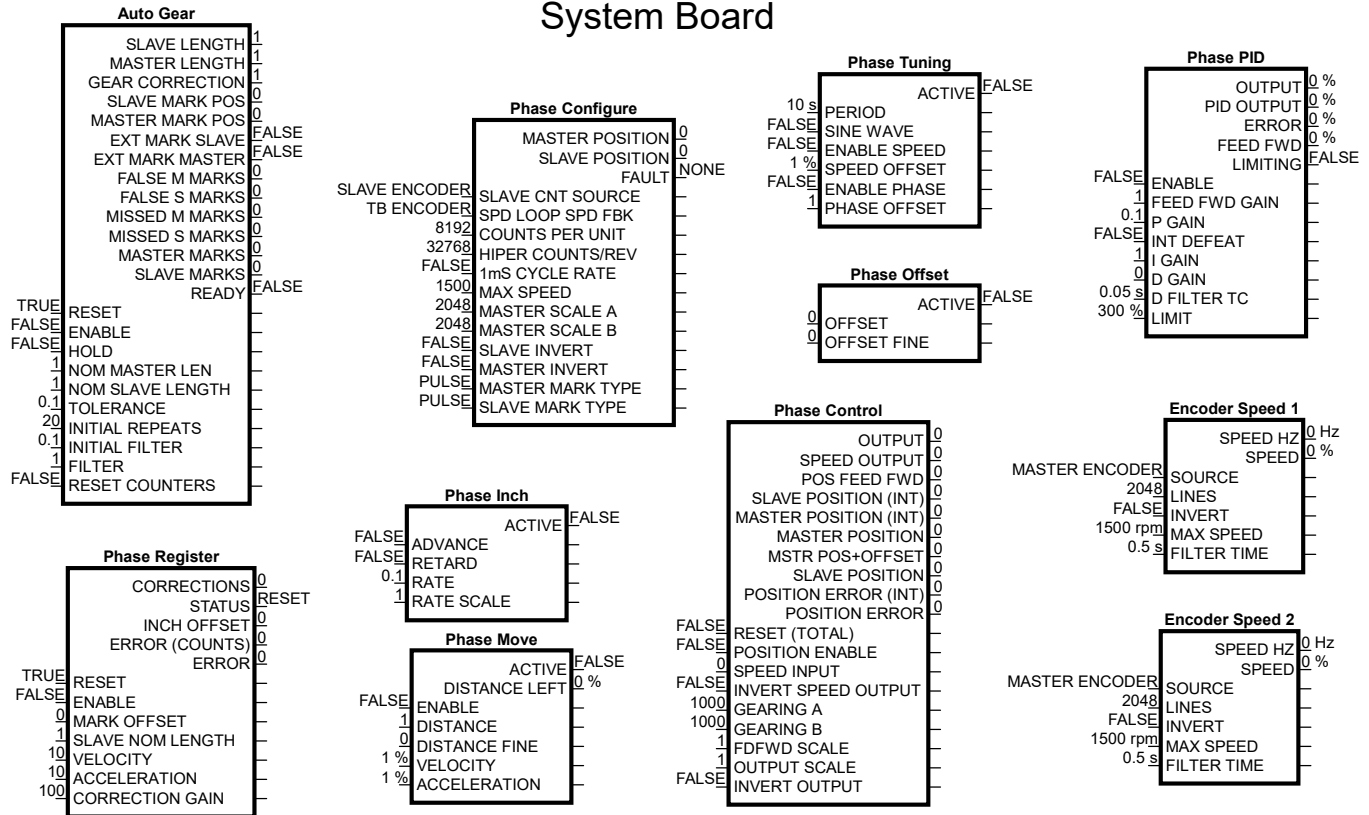

DWN			SIZE A	DWG. NO.	RFA
CHK		/1/T690v5_1.690.010	ISSUE		25 Jan 24
APP			SCALE	SHEET	5 OF 8
EDIT	LOC				

Menus

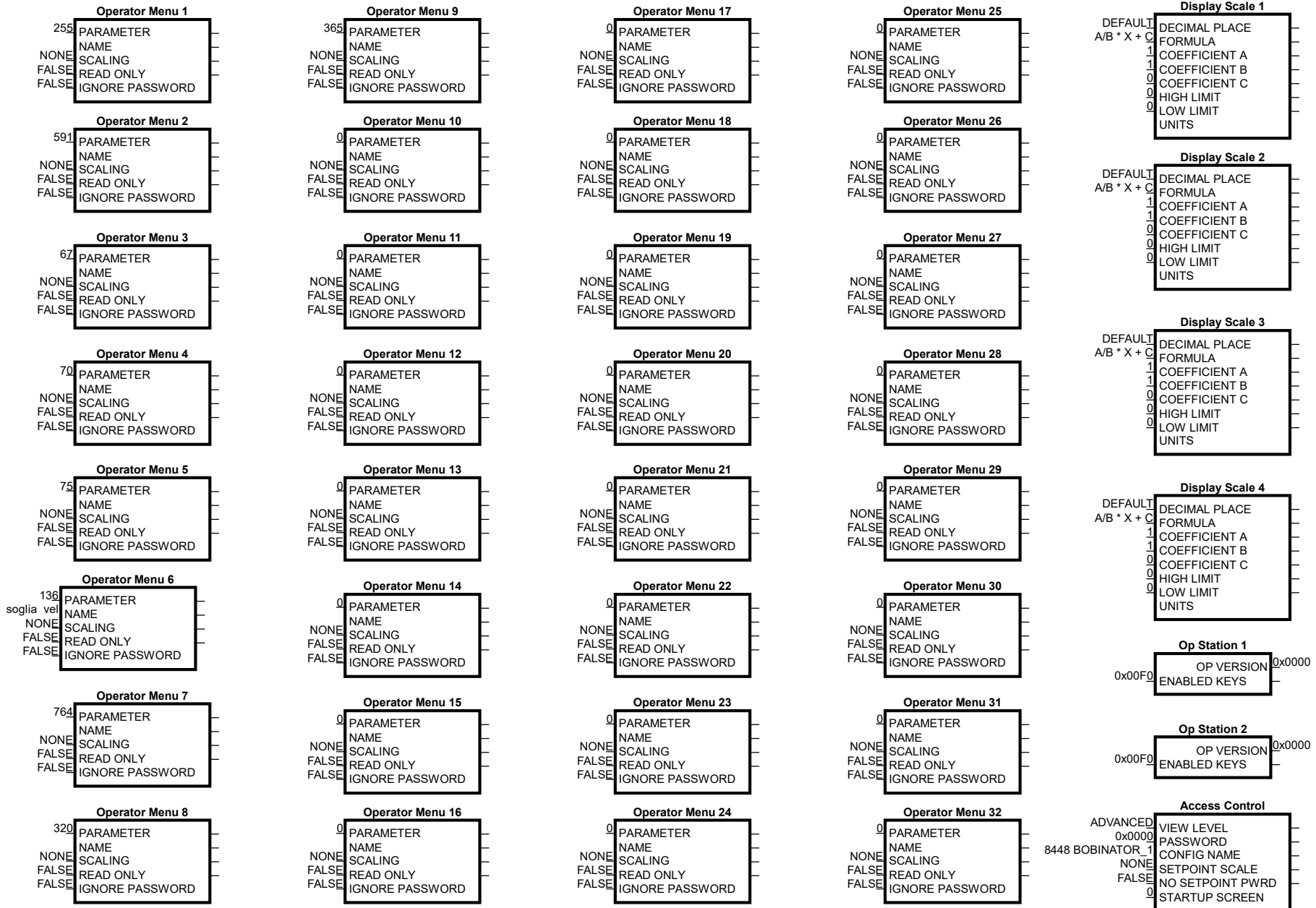

Configuration for version 5.x 690+

DWN			SIZE A	DWG. NO.	RFA
CHK		/1/T690v5_1.690.010	ISSUE		25 Jan 24
APP			SCALE	SHEET	6 OF 8
EDIT	LOC				

Miscellaneous

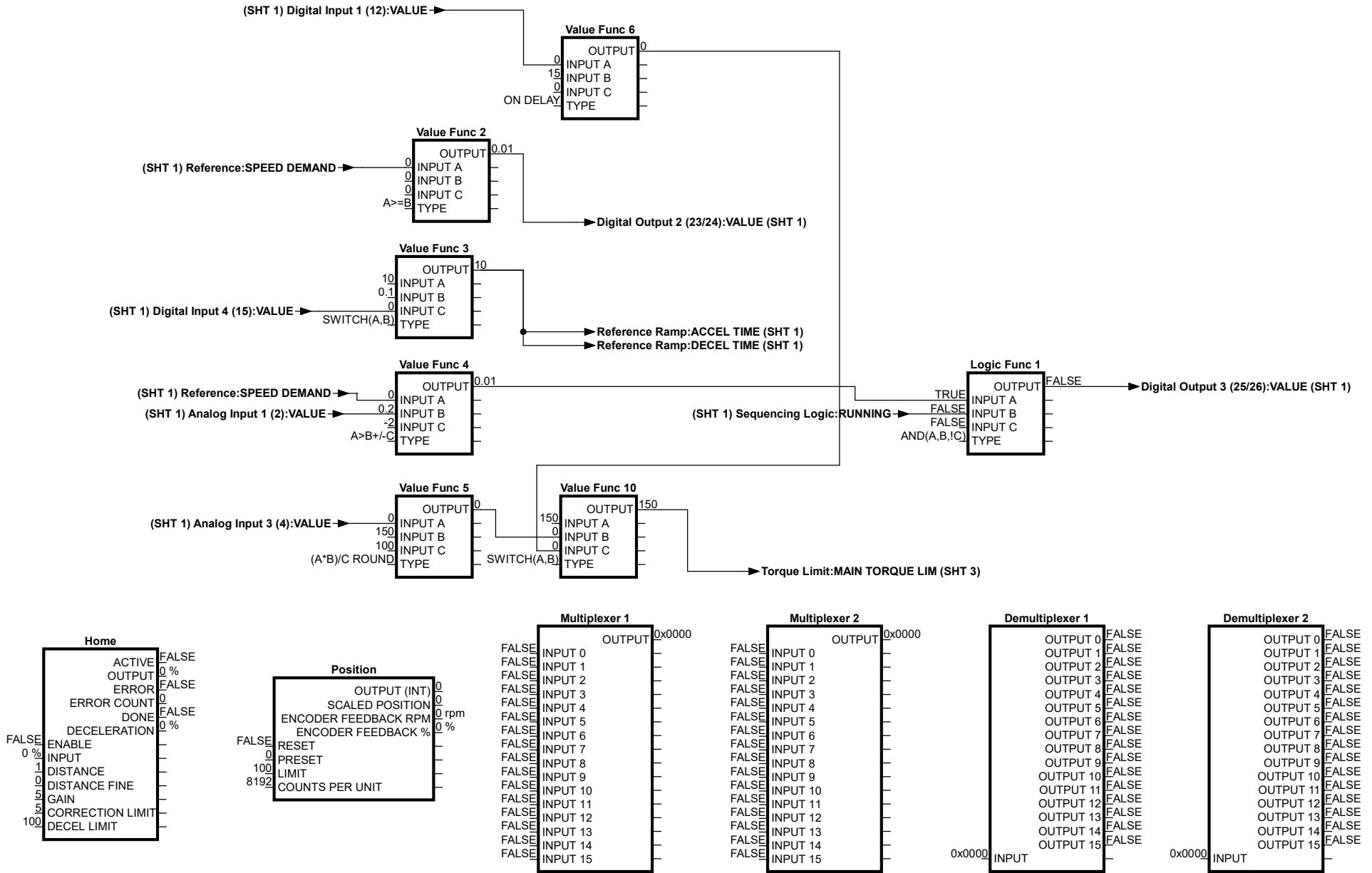

Configuration for version 5.x 690+

DWN			SIZE A	DWG. NO.	RFA
CHK		/1/T690v5_1.690.010	ISSUE		25 Jan 24
APP			SCALE	SHEET	7 OF 8
EDIT	LOC				

Timers

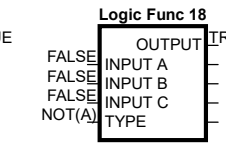
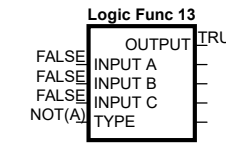
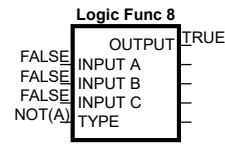
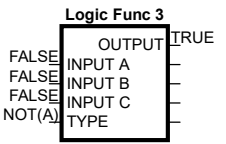
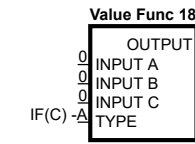
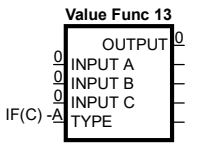
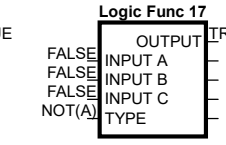
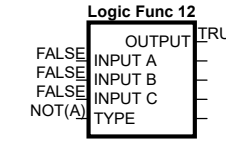
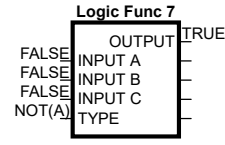
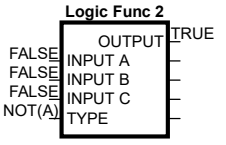
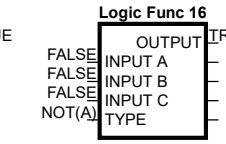
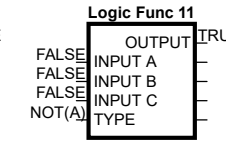
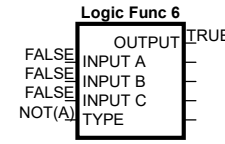
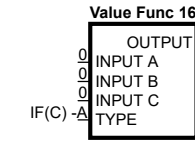
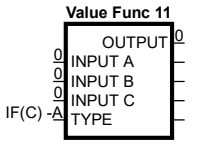
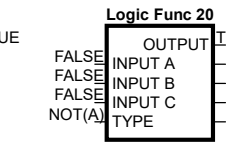
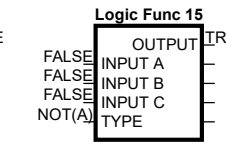
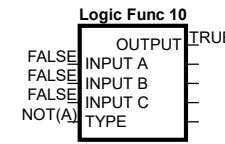
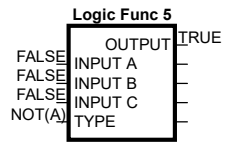
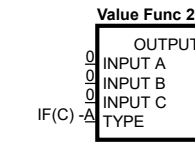
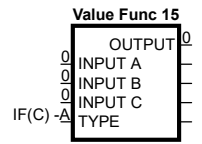
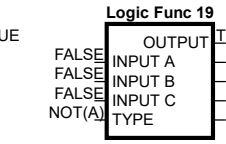
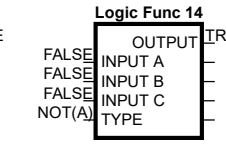
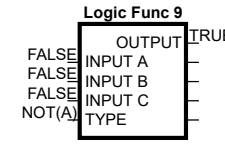
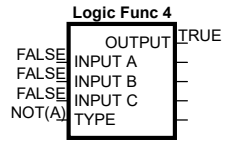
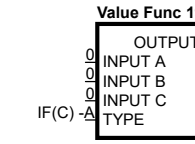
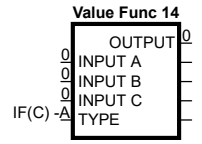
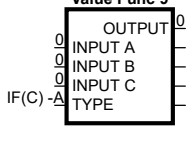
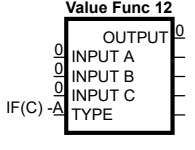
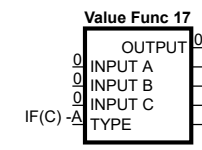
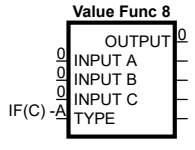
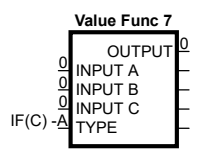
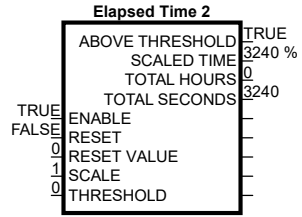
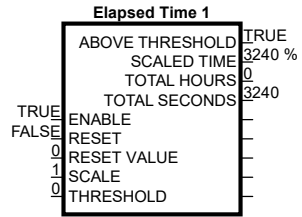

Configuration for version 5.x 690+

DWN			SIZE A	DWG. NO.	RFA
CHK		/1/T690v5_1.690.010	ISSUE		25 Jan 24
APP			SCALE	SHEET	8 OF 8
EDIT	LOC				